

BUSINESS MEETING ITEM COVER SHEET

DEPARTMENT County Attorney

DIVISION

TITLE Resolution 2016-121, approving 2016 Storm Drainage Criteria Manual & Land Use Docket DC-16-0003 (Text Amendments to the Boulder County Land Use Code related to 2016 Manual)

DOCUMENT TYPE Resolution

SUBTYPE SDCM + DC-16-0003

BUSINESS MEETING DATE 11/01/16

COMMISSIONERS' ACTION Approved Denied Other

ORIGINAL(S) RETURNED TO Vault

AGENDA ITEM NUMBER **5**

COMMENTS Original will go to the Recording Division first.

BOULDER COUNTY RESOLUTION 2016-121

Approving the 2016 Storm Drainage Criteria Manual and Land Use Docket DC-16-0003 (Text Amendments to Boulder County Land Use Code Related to the 2016 Manual)

Recitals

A. Boulder County first adopted the Boulder County Storm Drainage Criteria Manual in July of 1984 (the “1984 Manual”) to provide a uniform set of standards to guide development and design of drainage improvements in order to prevent future drainage problems and enhance the urban and natural environments.

B. By Resolution 94-185, adopted October 18, 1994, the Board of County Commissioners of Boulder County (“the Board”) approved a unified Boulder County Land Use Code, which has been amended from time to time (“the Code”). Per Section 7-900 of the Code, the 1984 Manual, as amended, is the authoritative reference for implementing storm drainage regulations contained in the Code.

C. The County Engineer and other Boulder County Transportation Department staff work with Land Use Department staff to administer the County’s storm drainage regulations.

D. After the September 2013 Flood, Transportation staff and engineering consultants using the County’s 1984 Manual realized its limitations in applying standards for road and bridge construction in both the plains and mountainous areas. As a result, Transportation staff initiated a comprehensive overhaul of the 1984 Manual to reflect more than 30 years of evolution in hydrologic and hydraulic methodologies and practices, as well as new environmental, regulatory and storm water management permitting requirements.

E. The County Planning Act, C.R.S. §§ 30-28-101 et seq., requires the Board to adopt regulations addressing the estimated construction cost and proposed method of financing of storm drainage facilities as may be required of a developer by the County; maps and plans for facilities to prevent storm waters in excess of historic runoff, caused by a proposed subdivision, from entering, damaging, or being carried by conduits, water supply ditches and appurtenant structures, and other storm drainage facilities; and standards and technical procedures applicable to storm drainage plans and related designs, in order to ensure proper drainage ways, which may require, in the opinion of the Board, detention facilities which may be dedicated to the county or the public, as are deemed necessary to control, as nearly as possible, storm waters generated exclusively within a subdivision from a one hundred year storm which are in excess of the historic runoff volume of storm water from the same land area in its undeveloped and unimproved condition. *Id.* § 30-28-133.

F. The County Planning Act also authorizes the Board to regulate the use of land for flood control. *Id.* § 30-28-113.

G. The Local Government Land Use Control Enabling Act, *id.* § 29-20-104, authorizes the

County to plan for and regulate the use of land by, among other things, regulating development and activities in hazardous areas, regulating the use of land on the basis of the impact thereof on the community or surrounding areas; and otherwise planning for and regulating the use of land so as to provide planned and orderly use of land and protection of the environment in a manner consistent with constitutional rights.

H. Under other statutory authority, the Board is empowered to adopt regulations related to the control of land use, including but not limited to Article 65.1 of Title 24 (Areas and Activities of State Interest); Articles 67 and 68 of Title 24 (Planned Unit Developments and Vested Rights); Articles 11 and 15 of Title 30 (County Powers and Police Power); Article 1 of Title 32 (Special District Control); and Article 2 of Title 43 (County Highways), C.R.S.

I. The Board is authorized to amend, repeal, or replace the 1984 Manual as it deems necessary and appropriate, and to amend the Code according to the procedures contained therein and various provisions of the County Planning Act.

J. At a public business meeting on September 20, 2016, the Board authorized staff to comprehensively update the 1984 Manual and propose companion text amendments to the Code (together described as “Docket DC-16-0003” or the “Docket”).

K. As set forth in the Transportation Department’s recommendation to the Board of County Commissioners dated October 27, 2016 (the “Staff Recommendation”), staff proposed a completely revised version of the Manual and a number of related text amendments to the Code (the “Proposed Text Amendments”).

L. The Boulder County Planning Commission (“Planning Commission”) held a duly noticed public hearing on the Docket on October 19, 2016. No members of the public testified. Planning Commission recommended a few changes to staff’s proposed 2016 Manual, proposed no changes to the Proposed Text Amendments, and unanimously approved the Docket and certified it to the Board for action.

M. On October 27, 2016, the Board held a duly noticed public hearing on the Docket (the “BOCC Hearing”) to consider the Staff Recommendation, which included changes to the proposed 2016 Manual based on the Planning Commission’s recommendations and public comments received prior to and after the Planning Commission hearing. No members of the public testified.

N. At the conclusion of the BOCC Hearing, the Board found that the new Manual as proposed by staff during the hearing (the “2016 Manual”) is ready for adoption and should replace the County’s 1984 Manual, as amended, in its entirety.

O. Also at the conclusion of the BOCC Hearing, the Board found that the Proposed Text Amendments, attached hereto as Exhibit A, meet the criteria for text amendments contained in Article 16 of the Code, in that the existing text is in need of amendment, the Proposed Text Amendments are not contrary to the intent and purpose of the Code, and the Proposed Text Amendments are in accordance with the Boulder County Comprehensive Plan.

P. A motion to approve the Docket was made at the Public Hearing by Commissioner Domenico, seconded by Commissioner Gardner, and passed by a 3-0 vote.

Therefore, the Board resolves:

1. Effective November 1, 2016, the 2016 Manual repeals and replaces the County's 1984 Manual, as amended, in its entirety.

2. Effective November 1, 2016, the Proposed Text Amendments are approved for incorporation into the Code.

3. Under § 30-28-125, C.R.S., the Board authorizes the Clerk to the Board to transmit this Resolution to the County Clerk and Recorder for filing and appropriate indexing. This transmittal should state recording Reference No. **2735571**, the recording of the Boulder County Land Use Code on November 4, 2005, which this transmittal amends. The Clerk to the Board need only attach Exhibit A (Proposed Text Amendments) in the transmittal to the Clerk and Recorder.

4. The County Engineer shall ensure an electronic copy of the 2016 Manual, a copy of which is attached hereto as Exhibit B, is accessible to the public at no charge.

[Signature page follows.]

ADOPTED on this 1st day of November, 2016.

BOULDER COUNTY



Elise Jones, Chair



Cindy Domenico, Vice Chair

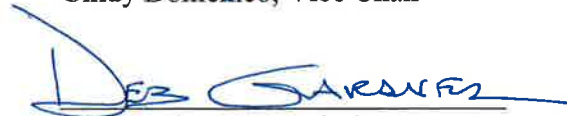

Deb Gardner, Commissioner



ATTEST:



Clerk to the Board

Exhibit A to Resolution 2016-121

Text amendments to Boulder County Land Use Code approved in Docket DC-16-0003 (2016 Storm Drainage Criteria Manual)

1. Article 3

- a. Add to 3-202(A)(7) and (8) a new subsection listing:
“Engineering Report”
- b. Amend 3-203(G)(1)(f) as follows:
“Drainage Report consistent with the Storm Drainage Criteria Manual”

2. Article 4

- a. Add to 4-601(A), Special Use Review Criteria, a new subsection 13:
“The proposed use shall not alter historic drainage patterns and/or flow rates unless the associated development includes acceptable mitigation measures to compensate for anticipated drainage impacts. The best available information should be used to evaluate these impacts, including without limitation the Boulder County Storm Drainage Criteria Manual, hydrologic evaluations to determine peak flows, floodplain mapping studies, updated topographic data, Colorado Geologic Survey landslide, earth/debris flow data, and creek planning studies, all as applicable given the context of the subject property and the application.”
- b. Amend 4-806(A)(6), Site Plan Review Criteria as follows:
“The proposed development shall not alter historic drainage patterns and/or flow rates or shall include acceptable mitigation measures to compensate for anticipated drainage impacts. The best available information should be used to evaluate these impacts, including without limitation the Boulder County Storm Drainage Criteria Manual, but not limited to hydrologic evaluations to determine peak flows, floodplain mapping studies, updated topographic data, Colorado Geologic Survey landslide, earth/debris flow data, and creek planning studies, all as applicable given the context of the subject property and the application.”

3. Article 7

- a. Prior to existing section 7-100, add a new introductory paragraph:
“This Article 7 is intended to apply to all types of development regulated by the Land Use Code. Except as may otherwise be required by law, the

Director may waive or alter any of these requirements if they are determined to be inappropriate or unnecessary in a particular instance given the nature and extent of the proposal.”

b. Amend 7-900(A) as follows:

- A. “The 2016 Storm Drainage Criteria Manual (SDCM), available from the County Engineer, shall be the authoritative reference for drainage and is incorporated into the Land Use Code by this reference. The Urban Storm Drainage Criteria Manual, available through the Urban Drainage and Flood Control District, may be used as an authoritative supplement. The Transportation Standards shall be used for design standards and specifications.
- B. Complete drainage systems for the entire development area shall be designed by a professional engineer, licensed in the State of Colorado.
- C. All drainage plans required to be submitted as part of a land use application under this Code must comply with the SDCM. The drainage system plan shall be depicted graphically identifying all existing drainage features which are to be used; all proposed surface drainage structures; and all appropriate designs, details, and dimensions necessary to clearly explain proposed construction materials and elevations.
- ~~D.~~ Development proposed within a Floodplain Overlay District, shall be capable of receiving a floodplain development permit from the County Engineer prior to receiving final plat approval. ~~by the Board of County Commissioners.~~
- E. Land which is subject to a possible upstream dam failure shall not be ~~platted~~ developed unless the potential flooding condition is alleviated according to plans approved by the County Engineer, unless otherwise approved by the State Engineer.
- F. Storm drainage systems shall be separate and independent of any sanitary sewer system and shall be designed in compliance with the following requirements:
1. The drainage system shall be designed to consider the drainage basin as a whole and shall accommodate not only runoff from the development area but also, where applicable, the system shall be designed to accommodate the runoff from those areas adjacent and upstream from the development itself, as well as its effects on lands downstream.
 2. If a development is proposed in phases, a general drainage plan for the entire area shall be presented with the first phase and

appropriate development stages for the drainage system for each section shall be indicated.”

c. Amend 7-901 Drainage Easements as follows:

- A. “Dedication to the County of a storm water or drainage easement or right-of-way ~~shall be provided~~ may be required if a proposed development is traversed by a watercourse, drainageway, channel, stream, water supply ditch, or canal. This right-of-way shall conform to the lines of such watercourse, and be of such width and construction as will be adequate for the purpose of maintenance, and the exclusion of improvements of the type which would interfere with runoff.
1. Where possible, the drainage shall be maintained by an open channel with rip-rap or grass lined banks, or such channel design that is in accordance with the SDCM. This channel shall be of adequate width for maximum potential volume off flow.
 2. The minimum requirements for such easements or rights-of-way shall be based on a base flood, but shall not be less than 20 feet in width.
 3. Where topography or other conditions are such as to make impractical the inclusion of drainage facilities within road rights-of-way, perpetual unobstructed easements at least 20 feet in width for such drainage facilities shall be provided across property outside the road lines and with satisfactory access to the road. Drainage easements shall be carried from the road to a natural watercourse or to other drainage facilities.
 4. When a proposed drainage system will carry water across private land outside the development, appropriate drainage rights must be secured and indicated on the plat or site plan.
 5. Low-lying lands along watercourses subject to flooding or overflowing during storm periods, whether or not included in areas for easement dedication, shall be preserved and retained in their natural state as drainage ways.
 6. Provision for the maintenance of such drainage areas shall be included as part of the development approval.”

Exhibit B to Resolution 2016-121
2016 Storm Drainage Criteria Manual

Boulder County Storm Drainage Criteria Manual



Photograph courtesy of Mr. David Mallory.



Photograph courtesy of Mr. David Mallory



Boulder County Storm Drainage Criteria Manual



Photograph courtesy of Mr. David Mallory.

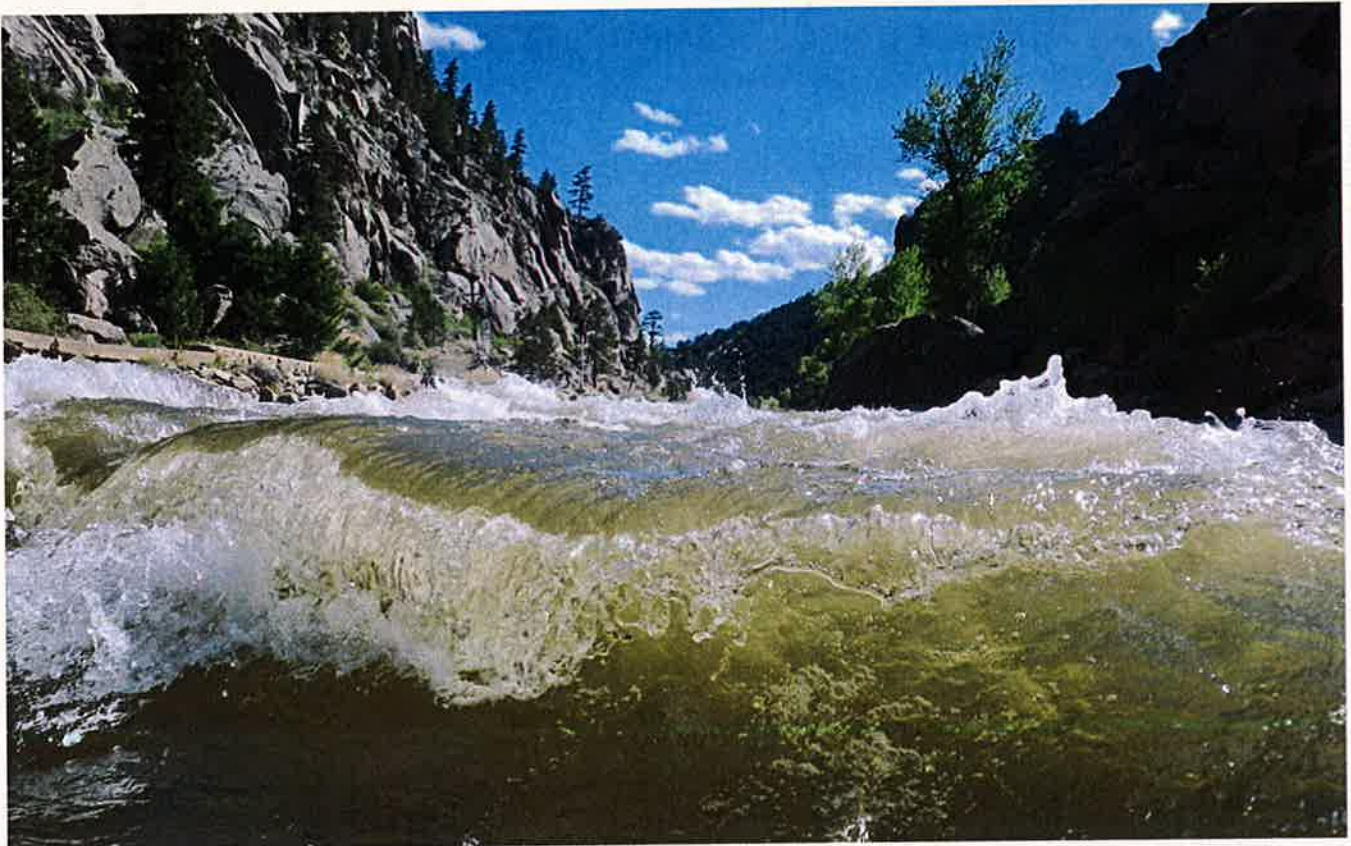

RSI-2576

Prepared by

RESPEC
720 S. Colorado Boulevard, Suite 410S
Denver, Colorado 80246

Prepared for

Boulder County Transportation
2525 13th Street #203
Boulder, Colorado 80304

November 2016

PREFACE

Boulder County, Colorado, first adopted the Boulder County Storm Drainage Criteria Manual (MANUAL) in July of 1984. Its creation was spurred by the need to provide a uniform set of standards that would be used to guide development and design drainage improvements in order to prevent future drainage problems and enhance the urban and natural environments. The original MANUAL also streamlined the review of drainage design submittals. This update carries forward the goals of the 1984 MANUAL. Additional factors influenced the format and content as well.

This updated MANUAL presents a document that is more brief and easy to understand than the original manual. Much of the original document was dedicated to design methodology rather than design criteria. This update still offers detailed design procedures for common storm drainage calculations used in Boulder County; however, the content is now more focused on providing specific criteria. The user will be referred to comprehensive design guidance provided in documents published by the Federal Highway Administration, the US Army Corps of Engineers Hydrologic Engineering Center, and the Urban Drainage and Flood Control District, which are now easily accessible via the internet.

In September of 2013, several days of intense rain fell along the front range of Colorado. Federal Emergency Declarations covered fifteen counties, including Boulder County. Many private bridges were washed out by runoff from these storms, and recovery is ongoing as of this update. One of the goals of the revised MANUAL is to provide clear guidance to land owners to help them achieve compliance and receive permits to construct replacement crossings. The impacts of these storm events also serve as a reminder that storm drainage criteria can at times have a critical impact on the level of resilience a community has in the face of a natural flood disaster. Another goal of the update to the MANUAL is to evaluate the priorities of Boulder County in terms of balancing public safety, infrastructure designs that provide the most resiliency after a large storm event, capital costs, and impacts to the natural environment, to name a few. The criteria in the MANUAL reflect those priorities.

Many federal and state stormwater regulations have changed since the MANUAL was first adopted in 1984. Many of these regulations involve floodplain development and water quality practices, both permanent and during construction. Because Boulder County participates in FEMA's Community Rating System, it has developed floodplain regulations and practices that allow its residents to purchase flood insurance at a discounted rate through the National Flood Insurance Program. These regulations were considered in the update to the MANUAL.

Finally, Boulder County is an MS4-permitted community with the Colorado Department of Health and Environment. This permit allows Boulder County to discharge runoff to waters of the state, but it requires that certain practices must be implemented. These include requiring erosion and sediment control on construction projects and requiring permanent water quality treatment for some developments. The requirements of the MS4 permit from the CDPHE were also considered in the update to the MANUAL.

In summary, although the original MANUAL served the county well for over thirty years, its criteria, derived from urban practices, have proven to be limited, mainly because of Boulder County's longstanding rural and mountainous conditions. The changes in stormwater criteria, practices, and regulations over time also necessitated a revision. This update is intended to address the great majority of design elements, site characteristics, and regulatory conditions that may be involved in drainage design projects in Boulder County. It also intends to provide clear guidance and criteria that will expedite the review and approval process within Boulder County, and has been written to address the unique priorities and obligations of Boulder County.

Boulder County Storm Drainage Criteria Manual Table of Contents

SECTION

- 100 GENERAL PROVISIONS
- 200 SUBMITTALS
- 300 POLICY
- 400 PLANNING
- 500 RAINFALL
- 600 RUNOFF
- 700 OPEN CHANNELS
- 800 STORM DRAINS
- 900 ROADWAYS
- 1000 CULVERTS AND BRIDGES
- 1100 HYDRAULIC STRUCTURES
- 1200 DETENTION AND PERMANENT WATER QUALITY
- 1300 CONSTRUCTION WATER QUALITY
- 1400 ENVIRONMENTAL AND REGULATORY PERMITTING

APPENDICES

- APPENDIX A BIOENGINEERING COMPONENTS SCHEMATIC DETAILS

Section 100 General Provisions

Table of Contents

101	SHORT TITLE	100-1
102	JURISDICTION	100-1
103	LEGAL BASIS	100-1
104	PURPOSE	100-1
105	ENACTMENT AUTHORITY	100-1
106	AMENDMENT AND REVISIONS.....	100-2
107	ENFORCEMENT RESPONSIBILITY.....	100-2
108	INTERPRETATION	100-2
109	DESIGN EXCEPTIONS	100-3
110	ABBREVIATIONS	100-4
111	GLOSSARY.....	100-5

Section 100 General Provisions

101 SHORT TITLE

These regulations, together with all future amendments, shall be known as the Boulder County Storm Drainage Criteria Manual (referred to herein as MANUAL) as referenced in the Boulder County Land Use Code (referred to as CODE).

102 JURISDICTION

This MANUAL shall apply to all land within the unincorporated areas of Boulder County.

103 LEGAL BASIS

Because the legal basis and practice of establishing drainage policy and criteria is well established, a discussion on it is not presented herein. If a reader is interested in the history of case law regarding establishing drainage policy, the Drainage Law chapter of the Urban Storm Drainage Criteria Manual, available through the Urban Drainage and Flood Control District, offers a lengthy and detailed review.

104 PURPOSE

Presented in this MANUAL are the minimum design and technical criteria for the analysis and design of storm drainage and water quality facilities. All proposed construction submitted for approval under the provisions of the CODE shall include adequate storm drainage system analyses and appropriate drainage system design. Such analyses and design shall conform to the criteria set forth herein. Individuals using this MANUAL are assumed to possess a working knowledge of hydrology and hydraulics and to have experience in storm drainage design and analysis. Publications referenced in this MANUAL can provide additional guidance as needed. Where the criteria in this MANUAL vary from those found in other Boulder County publications, the criteria in this MANUAL shall govern.

105 ENACTMENT AUTHORITY

The CODE has been adopted pursuant to the authority conferred within the following sections of the Colorado Revised Statutes, as amended:

1. Article 32 of Title 22 (Zoning, Planning, and Building Code Duties of School District Boards)
2. Article 65.1 of Title 24 (Areas and Activities of State Interest)
3. Article 67 of Title 24 (Planned Unit Development Act of 1972)

4. Article 68 of Title 24 (Vested Property Rights)
5. Article 6 of Title 28 (Division of Aviation)
6. Article 20 of Title 29 (Local Government Land Use Control Enabling Act)
7. Article 11 of Title 30 (County Powers and Functions)
8. Article 15 of Title 30 (County Regulations under Police Power)
9. Article 28 of Title 30 (County Planning and Building Codes)
10. Article 1 of Title 32 (Special District Act/Provisions)
11. Article 1 of Title 34 (Preservation of Commercial Mineral Deposits)
12. Article 30.5 of Title 38 (Conservation Easements)
13. Article 2 of Title 43 (State, County, and Municipal Highways)
14. Article 4 of Title 41 (Airports).

The CODE refers to this MANUAL as the authoritative reference for drainage. The Urban Storm Drainage Criteria Manual (USDCM), available through the Urban Drainage and Flood Control District (UDFCD) (<http://udfcd.org/criteria-manual>), may be used as an authoritative supplement to the MANUAL. The Boulder County Multimodal Transportation Standards shall be used for design standards and specifications; however, any drainage criteria included in the Boulder County Multimodal Transportation Standards is superseded by the criteria contained in this MANUAL. All sections, paragraphs, and subparagraphs enumerated in this MANUAL shall be considered incorporated into the CODE by reference.

106 AMENDMENT AND REVISIONS

These policies and criteria are basic guidelines, which may be amended as new technology is developed or experience is gained through use of this MANUAL that indicates the need for revision. Amendments and revisions to this MANUAL will be recommended by the County Engineer and submitted to the Board of County Commissioners for acceptance.

107 ENFORCEMENT RESPONSIBILITY

The enforcement of the provisions of this MANUAL will be in accordance with the most recent version of the CODE.

108 INTERPRETATION

The principles set forth in the most recent version of the CODE shall be used in interpreting the provisions of this MANUAL.

109 DESIGN EXCEPTIONS

The county recognizes that in certain limited instances, such as in, but not limited to, the county's historic townsites, environmentally significant areas, or areas with significant view sheds, it may be exceptionally difficult to both conform to these criteria and maintain the special character and environmental values associated with such areas. In these instances, the applicant will document in writing, good and sufficient cause for a requested Design Exception on the most recent Boulder County Design Exception Request Form, which is available from the Boulder County Department of Transportation (<http://www.bouldercounty.org/doc/transportation/designexceptionrequestform.pdf>). It shall be stamped and signed by a Colorado Professional Engineer. The rationale for the Design Exception Request shall demonstrate the following:

1. It is not likely to unacceptably compromise public safety;
2. It is not contrary to best engineering practices, as reflected by the approach outlined in the latest version of the USDCM, an authoritative supplement to this MANUAL;
3. It is not contrary to the intent and general purpose of this MANUAL, including without limitation an appropriate balancing of safety, multimodal mobility, and pursuit of the environmental, community, and sustainability goals outlined in the Comprehensive Plan;
4. It does not result in a significant impact to the public due to maintenance of the improvements;
5. It is the minimum exception from the criteria in this MANUAL necessary to afford relief, given the context;
6. It reflects special conditions or exceptional characteristics of the proposal, not created by the applicant, that justify an exception from strict and literal interpretation of this MANUAL to avoid unusual difficulties or unnecessary hardship; and
7. It is reasonably necessary for the health, safety, and welfare of the public.

Upon receipt of a written request for a Design Exception from a particular criterion in this MANUAL, the County Engineer may issue a determination on whether a Design Exception should be granted or denied given the context. The County Engineer will provide a copy of the determination to the applicant and, if applicable, to the Land Use Department.

The Board of County Commissioners acknowledges that some judgments ought to be made by technical experts, particularly those involving public safety and prevailing engineering practice. Therefore, the Board of County Commissioners typically defers to the professional judgment of the County Engineer. However, the Board of County Commissioners retains its discretion to make the final decision on whether a Design Exception is appropriate in light of the context of a land use application and the applicable Land Use Code criteria.

110 ABBREVIATIONS

AASHTO	American Association of State Highway and Transportation Officials
ASTM	American Society of the International Association for Testing and Materials
BFE	Base Flood Elevation
BMP	Best Management Practice
CAD	Computer-Aided Design
CDOT	Colorado Department of Transportation
CDPHE	Colorado Department of Public Health and Environment
CDPS	Colorado Discharge Permit System
cfs	Cubic Feet per Second
cfs/ft	Cubic Feet per Second per Foot
CLOMR	Conditional Letter of Map Revision
CMP	Corrugated Metal Pipe
CMPA	Corrugated Metal Pipe Arch
CUHP	Colorado Urban Hydrograph Procedure
CWCB	Colorado Water Conservation Board
DPR	Development Plan Review
DRCOG	Denver Regional Council of Governments
EA	Environmental Assessment
EGL	Energy Grade Line
EIS	Environmental Impact Statement
EPA	U.S. Environmental Protection Agency
ESA	Endangered Species Act
FEMA	Federal Emergency Management Agency
FHAD	Flood Hazard Area Delineation
FHWA	Federal Highway Administration
FIR	Field Inspection Review; CDOT/county Term for Preliminary Design or Review
FIS	Flood Insurance Study
FONSI	Finding of No Significant Impact
FOR	Final Office Review; CDOT/county term for Final Design or Review
fps	Feet per Second
GSB	Grouted Sloping Boulder
HDS	Hydraulic Design Series
HEC	Hydrologic Engineering Center

HERCP	Horizontal Elliptical Reinforced Concrete Pipe
LOMR	Letter of Map Revision
MDCIA	Minimizing Directly Connected Impervious Areas
MEP	Maintenance Eligibility Program
MS4	Municipal Separate Storm Sewer System
NEPA	National Environmental Policy Act
NFIP	National Flood Insurance Program
NOI	Notice of Intent
NPDES	National Pollutant Discharge Elimination System
NRCS	National Resource Conservation Service
PWQ	Permanent Water Quality
RCBC	Reinforced Concrete Box Culvert
RCP	Reinforced Concrete Pipe
ROD	Record of Decision
ROW	Right-of-Way
SCS	Soil Conservation Service
SPP	Structural Plate Pipe
SPPA	Structural Plate Pipe Arch
SWMP	Stormwater Management Plan
TAPE	Technology Assessment Protocol – Ecology
TSS	Total Suspended Solids
UDFCD	Urban Drainage and Flood Control District
USACE	U.S. Army Corps of Engineers
USBR	U.S. Bureau of Reclamation
USDCCM	Urban Storm Drainage Criteria Manual
USGS	U.S. Geological Survey
WQCD	Water Quality Control Division
WQCV	Water Quality Capture Volume
WADOE	Washington State Department of Ecology

111 GLOSSARY

In addition to those definitions included in the CODE, the following terms may be used throughout this MANUAL:

As-Built Drawings Certified drawings showing the actual dimensions, elevations, and other conditions of the drainage facilities after construction

CODE	The most recent version of the Boulder County Land Use Code
Culvert	A conduit that does not have a manhole or other enclosed structure at either end that conveys streamflow and stormwater runoff under a road, railroad, or other obstruction
Local Detention	Detention provided to serve only the developing area in question and not any of the area outside of the development. Also called "on-site detention"
Local Drainage System	The storm drainage system that conveys the minor and major storm runoff to the Major Drainage System and serves only the property within the development in question
Major Drainage System	The storm drainage system that conveys the minor and major storm runoff and serves areas both within and outside the development in question
Major Storm	The 100-year return period storm event
MANUAL	The Boulder County Storm Drainage Criteria Manual
Minor Drainage System	The storm drainage system that conveys runoff from storms with a 5-year return period
Minor Storm	The 5-year return period storm event
On-Site Detention	See Local Detention
Raw Water Ditch	An open channel used to move nonpotable water that is not runoff from a storm event. This water may include irrigation water, water destined for a water treatment plant, and water intended for other non-irrigation purposes.
Regional Detention	Detention provided to serve areas both within and outside of the development in question
Storm Drain System	The storm drainage system composed of storm inlets, pipes, manholes or junctions, outlets, and other appurtenant structures designed to collect and convey the minor storm runoff

Section 200 Submittals Table of Contents

201 REVIEW PROCESS	200-1
202 BOULDER COUNTY PROJECTS	200-1
203 PRIVATE PROJECTS	200-1
204 DRAINAGE PLANS AND REPORTS	200-1
205 ADDITIONAL PRE-PROJECT REQUIREMENTS.....	200-2
206 AS-BUILT REQUIREMENTS.....	200-3
207 REFERENCE	200-3

List of Figures

200-1 Boulder County Drainage Report Checklist.....	End of Section
200-2 Boulder County Drainage Plan Checklist.....	End of Section

Section 200 Submittals

201 REVIEW PROCESS

The CODE discusses approvals and permits necessary before development. The Boulder County Transportation Department is a referral agency in the development review process, and a general overview of the review process by the Transportation Department is included in the Boulder County Multimodal Transportation Standards. The submittal requirements for each type of project will be different depending on the scope and location of the improvements. The requirements for a commercial building addition, a new roadway, a new bridge, channel restoration, and construction of a single-family residence will all vary from each other, depending on specific site conditions and impacts.

202 BOULDER COUNTY PROJECTS

For projects sponsored by Boulder County, the county has adopted the FIR/FOR terminology used by CDOT and has specific submittal requirements at each phase of the project. A preliminary grading and drainage plan and drainage report are required at the FIR, and a final drainage and grading plan and drainage report are required at the FOR.

203 PRIVATE PROJECTS

To facilitate the submittal process for both the applicant and the county, a pre-application conference with the Boulder County Transportation Department may be required of land-use permit applicants whose projects involve floodplain, road, access, traffic concerns, parking design and engineering, vehicular movement patterns and volumes, or any other transportation-related concern. The need for a pre-application conference with the Boulder County Transportation Department will be determined by the Land Use Department in consultation with the County Engineer. The pre-application conference shall include a discussion regarding current regulations, required submittal procedures, potential drainage problems and solutions, and specific submittal requirements.

204 DRAINAGE PLANS AND REPORTS

The purpose of the preliminary and final drainage plan and report is to identify existing site conditions and drainage problems, as well as those anticipated to result from development (whether on site or off site), and to present conceptual and final solutions to those problems. All plans and reports shall be submitted as a single pdf document, printable to scale on 8½ × 11 or 11 × 17 paper.

The format and contents of the drainage plan and report are specified in the Drainage Plan Checklist and the Drainage Report Checklist, included as Figures 200-1 and 200-2. These checklists shall be included as appendices to the drainage report. All checklist items are required for both preliminary and final plans and reports unless they are not applicable because of the project location or scope. Preliminary plans and reports must include a final version of all items relating to existing conditions and a conceptual version of all items relating to proposed conditions.

Each plan and report shall be prepared by a professional engineer licensed in Colorado. The report shall contain a certification page that states the following:

I hereby certify that this plan and report for the [preliminary][final] drainage design of [Project Name/Name of Development] was prepared by me, or under my direct supervision, in accordance with the provisions of the Boulder County Storm Drainage Criteria Manual.

Registered Professional Engineer

(Affix Seal)

State of Colorado No. _____

Preliminary drainage plans and reports for private projects should be submitted early enough in the project for the county to have the opportunity to provide feedback on the conceptual design before proceeding to final design. Final drainage plans and reports must be submitted and accepted prior to project approval. The project schedule should include several weeks of review time for county staff for both the preliminary and final submittals. The final drainage plan and report shall be included as part of the construction documents for all facilities affected by the drainage plan.

205 ADDITIONAL PRE-PROJECT REQUIREMENTS

Depending on the nature and location of a project, multiple other permits and requirements from state and federal agencies may be required. Section 1400, Environmental and Regulatory Permitting discusses several of the requirements that may apply. Section 300, Policy discusses county and FEMA floodplain policies and requirements. Section 1300, Construction Water Quality provides guidance on when a stormwater management plan is required and how to develop one. These sections should be reviewed to ensure all necessary permits are acquired and applicable policies and regulations are followed. The certification page in the final drainage report shall include the following statement:

I hereby certify that to the best of my professional knowledge all applicable state and federal permits, clearances, and environmental compliances have been obtained.

Registered Professional Engineer

(Affix Seal)

State of Colorado No. _____

206 AS-BUILT REQUIREMENTS

The special provisions for surveying within the project specifications for construction shall include a requirement that as-built information be developed during construction to document the as-built location and elevation of the improvements. Specific requirements will be determined by the County Engineer on a case-by-case basis, but a minimum requirement will be that the Contractor legibly mark the plans with any field changes and notify the engineer of any significant changes. For private projects, the construction contractor or design engineer may be required to submit as-built drawings in CAD in a format specified by the county. As-built information may not be required for single-family residence construction that has no major drainage infrastructure.

As-built survey information shall include the following items:

1. Locations and elevations for abutments, wingwalls, retaining walls, or other structures.
2. Bridge superstructure and substructure locations and elevations.
3. Invert elevations, locations, and lengths for pipes, culverts, and inlets.
4. Rim elevations and locations for manholes and inlets.
5. Top-of-wall and invert elevations and locations of all detention and permanent water quality facilities and appurtenances.
6. Any other items required by the engineer.

207 REFERENCES

Boulder County Land Use Department, 2015. *Land Use Code*, prepared by the Boulder County Land Use Department, Boulder, CO.

Boulder County, 2012. *Boulder County Multimodal Transportation Standards*, prepared by Boulder County, Boulder, Colorado.

Figure 200-1. Boulder County Drainage Report Checklist

Included			Report Requirements
Yes	No	N/A	
1. Cover Sheet			
			A. Name of Project
			B. Address
			C. Owner
			D. Developer
			E. Engineer
			F. Boulder County Case/Project Number
			G. Submittal and Revision Dates as applicable
2. Certification Statements			
			Provide certification statements in Section 200 on a fly page after the report cover.
3. General Location and Description			
			A. Name of Project
			1. Site Vicinity Map
			2. Township, Range, Section, ¼ Section
			3. All roadways adjacent to and within the project area
			4. Names of surrounding developments and their land use/zoning
			B. Description of Property
			1. Area in acres
			2. Ground cover, vegetation, site topography, slopes, etc.
			3. NRCS soil classification map and discussion
			4. Major and minor drainageways
			5. Regulatory floodplains (FEMA or Boulder County)
			6. Existing irrigation facilities
			7. Significant geologic features
			8. Existing and proposed land use activities
			9. Geotechnical/groundwater investigation information
4. Drainage Basins and Subbasins			
			A. Major Drainage Basins
			1. Onsite/offsite major drainage basin characteristics and flow patterns
			2. Discussion of all planning studies that affect major drainageways
			3. Discussion of the condition of channels within or adjacent to the project including need for improvement
			4. Discussion of impacts of offsite flow patterns under fully developed conditions
			B. Minor Drainage Basins
			1. Onsite/offsite minor drainage basin characteristics and flow patterns
			2. Discussion of impact to/by irrigation facilities
			3. Discussion of impacts of offsite flow patterns under fully developed conditions
5. Drainage Design Criteria			
			A. Applicable Regulations and Permits
			1. County criteria and permits
			2. Other criteria and permits (FEMA, UDFCD, 404, ESA, etc.)

Figure 200-1. Boulder County Drainage Report Checklist

Included			Report Requirements
Yes	No	N/A	
			B. Drainage Studies, Outfall Systems Plans, Site Constraints
			1. Discuss previous drainage studies or master plans for the project site and adjacent areas and their influence on facility designs
			2. Discuss previous drainage studies or master plans for the project site and adjacent areas and their influence on facility designs
			3. Discuss impacts to stormwater design caused by site constraints such as streets, utilities, light rail rapid transit, existing structures, etc.
			C. Hydrology
			1. Runoff calculation methods
			2. Design storm(s)
			3. Design rainfall
			4. Detention calculations (drainage area map, storage, release rate, etc.)
			D. Hydraulics
			1. Velocity and capacity calculations for inlets, culverts, channels, etc.
			2. HGL calculation methods and loss coefficients
			3. Water surface profile calculation methods
			E. Water Quality
			1. Proposed construction BMPs and source controls
			2. Identify permanent water quality design criteria
			F. Groundwater
			Discuss groundwater investigations/impacts/remediation per 404.3
6. Facility Design			
			A. Stormwater Conveyance Facilities
			1. General conveyance concepts
			2. Use of ecological design components
			3. Proposed drainage paths and patterns
			4. Storm sewer and inlet sizes/locations, tributary areas, peak flows
			5. Outfall locations, flow rates, energy dissipation
			6. Method of conveyance from outfall to major drainageway including capacity evaluation
			7. Open channel, ditch, and swale designs
			8. Allowable street capacity
			9. Maintenance and easement requirements
			10. Offsite facilities needed to convey flow to major drainageway
			B. Detention Storage and Permanent Water Quality
			1. Detention design and release rates including overflow spillway
			2. Outfall location and energy dissipation
			3. Discharge conveyance to nearest major drainageway
			4. Draft maintenance agreement and easement requirements*
			5. Exemption being requested and documentation provided

*A signed maintenance agreement is required prior to final acceptance.

Figure 200-1. Boulder County Drainage Report Checklist

Included			Report Requirements
Yes	No	N/A	
			C. Floodplain
			1. Source of floodplain information (FEMA, UDFCD, Boulder County)
			2. Project impacts to the floodplain
			3. Required modification studies
			4. Acknowledgement of required floodplain development permit
			7. Conclusions
			A. Compliance with Standards
			B. Variances
			C. Effectiveness of Drainage Concept
			8. References
			Reference all criteria, master plans, reports, and technical information used.
			9. Appendices
			A. Hydrologic calculations
			B. Hydraulic calculations
			C. Detention and Permanent Water Quality calculations
			D. References (copies of pertinent portions of reference materials)

Figure 200-2. Boulder County Drainage Plan Checklist

Included			Plan Requirements
Yes	No	N/A	
1. Overall Drainage Plan			
			A. Title block, north arrow, scale, paper size, and legend
			B. Boundaries of entire project or development
			C. Limits of major drainage basins including offsite basins where possible
			D. Drainage patterns to, from, and within the site
			E. Topographic information
			F. Existing stormwater facilities u/s, d/s, and within the site
			G. Key map of locations of detailed drainage plan sheets
2. Detailed Drainage Plans			
			A. Title block, north arrow, scale, paper size, and legend
			B. Basin designations, design points, flow rates, volumes, release rates, etc.
			C. Scale of 1"=20' to 1"=100' sufficient to show detail
			D. Existing and proposed contours with 2' maximum interval (5' where slope exceeds 10%); contours must extend beyond project boundary
			E. Existing utilities and structures
			F. Property, right-of-way, and easement lines
			G. Adjacent developments and ownership
			H. Roadway ROW and roadside or storm drain improvements
			I. Drainage basin delineations
			J. Show existing and proposed irrigation facilities, swales, channels, ditches, storm sewers, culverts, detention ponds, and water quality structures or features. Provide information on materials, sizes, slopes, and shapes.
			K. Proposed outfalls points and flow rates and facilities required to convey flow downstream
			L. Location and elevation of all existing and proposed 100-year floodplains, the name of the waterway, and the source of the information (e.g. FEMA FIS, FEMA FHAD, Boulder County data, UDFCD FHAD, etc.)

Section 300 Policy Table of Contents

301	INTRODUCTION	300-1
302	DEVELOPMENT AND PLANNING	300-1
303	MULTIPURPOSE RESOURCE.....	300-2
304	TECHNICAL CRITERIA.....	300-2
305	RAW WATER AND WATER RIGHTS.....	300-2
306	ROADWAYS	300-3
307	ECOLOGICAL DESIGN.....	300-4
308	SUMP PUMPS.....	300-4
309	FLOODPLAIN MANAGEMENT.....	300-5
310	DETENTION.....	300-5
311	WATER QUALITY.....	300-5
312	MAINTENANCE.....	300-6
313	TRANSBASIN DIVERSIONS	300-6

Section 300 Policy

301 INTRODUCTION

Provisions for adequate drainage are necessary to preserve and promote the general health, welfare, and economic well-being of the region. Drainage is a regional feature that affects all governmental jurisdictions and all parcels of property. This characteristic makes it necessary to formulate a program that balances both public and private involvement. Overall coordination and master planning must be provided by various government entities, but drainage planning must be integrated on a regional level.

When planning drainage facilities, certain underlying principles provide direction for the effort. These principles are made operational through a set of policy statements. The application of the policy is in turn facilitated by technical criteria and data. When considered in a comprehensive manner, on a regional level with public and private involvement, drainage facilities are provided in a manner that will enhance the general health and welfare of the region, ensure optimum economic and social relationships, and avoid uneconomic water losses and disruption of raw water delivery.

302 DEVELOPMENT AND PLANNING

Drainage is a component of development, and drainage facilities must be planned alongside development. Drainage planning should consider local and regional systems. Drainage planning considerations are discussed in depth in Section 400 Planning.

The policy of Boulder County shall be to consider storm drainage as an integral component of development and to require storm drainage planning for all development to include the allocation of space for drainage facilities.

Storm drainage can be a regional phenomenon and may not respect jurisdictional boundaries. Planning must emphasize jurisdictional cooperation, when appropriate, to accomplish mutually beneficial goals.

The policy of Boulder County shall be to pursue a jurisdictionally unified drainage effort to ensure an integrated plan, where applicable and appropriate.

Because drainage boundaries are not jurisdictional and new development cannot plan for the entire county, the county should take the lead role and encourage preparation of drainage master plans.

The policy of Boulder County shall be to encourage the development of detailed regional drainage master plans that will set forth site requirements for new development and identify the required public improvements. Master plans shall be prepared and adopted.

303 MULTIPURPOSE RESOURCE

Every community has competing demands for space and resources. Stormwater and drainage facilities should be managed and developed to serve as many uses and to provide as much benefit as is practicable at any given location. Examples of this include incorporating boatable drops, ecological design concepts, and space for trails into open channel design. It may also include constructing soccer fields within a floodplain where other development is not permitted or converting a landscaped area to a rain garden to treat water quality.

The policy of Boulder County shall be to consider stormwater runoff as a resource that should be incorporated into the community as a recreational, social, environmental, and aesthetic resource with multiple possible uses consistent with adopted plans.

304 TECHNICAL CRITERIA

The design criteria presented in this MANUAL represent the values and priorities of Boulder County with regard to stormwater management. The criteria are intended to establish guidelines, standards, and methods for effective planning and design. These criteria will be revised and updated as necessary to reflect advances in best practices in the field of urban water resources management and changes within Boulder County.

Boulder County requires all storm drainage facilities be planned and designed in accordance with the criteria set forth in this MANUAL, including referenced technical design documents, as amended.

Many of the criteria in this MANUAL refer to the major and minor storm or the major and minor storm runoff events.

The major storm shall be the rainfall event having a 1 percent chance of occurring in any given year, also known as the 100-year event. The minor storm shall be the rainfall event having a 20 percent chance of occurring in any given year, also known as the 5-year event.

305 RAW WATER AND WATER RIGHTS

Storm drainage infrastructure should be designed and developed so as not to interfere with existing water rights or affect the value, quality, and use of the water. Existing drainageways and storage facilities are often intertwined within the system of water rights in Colorado. This relationship must be addressed to preserve the integrity of water rights.

The policy of Boulder County shall be to recognize existing and potential future water rights and to include the interrelationship of water rights and stormwater management in the planning and design of the proposed drainage facility.

Many ditches and reservoirs that provide raw water for drinking and non-potable irrigation are located within Boulder County. These ditches and reservoirs historically intercepted runoff from rural or agricultural areas that were highly pervious, generally without major problems. With development, runoff pollution, rates, volumes, and frequencies have all increased and raw water facilities can no longer be used as drainage facilities.

Raw water ditches should not be used as basin boundaries. Ditches will generally be flowing full or near full during large storms, and tributary runoff will flow across the ditch.

The policy of Boulder County shall be to require drainage analysis to assume that no raw water ditch intercepts storm runoff from any basin above it, and that that all area above raw water ditches is tributary to the area downstream of the ditches. Raw water ditches shall not be assumed or relied upon to convey stormwater runoff.

If new development will alter existing patterns of storm drainage into raw water ditches or reservoirs by increasing flow rates or volumes, or by changing water quality or points of concentration, the written consent from the reservoir or ditch owners (individuals and/or company) shall be submitted with the development application. The change in runoff discharge into a raw water ditch shall only be approved if it is consistent with an adopted master drainage plan, approved by the reservoir or ditch owner(s) in writing, and in the county's best interest.

If raw water ditches cross major drainageways within a developing area, the developer shall be required to design, obtain approval from ditch owner(s), and construct appropriate structures to separate peak storm runoff from ditch flows.

306 ROADWAYS

The design of roadways and drainageways with respect to each other must balance public safety and convenience with fiscal responsibility. Section 900 discusses allowable roadway encroachment and overtopping by stormwater during design events for various roadways classifications within the county.

Boulder County recognizes that during major storm events, roadways may experience overtopping for some period of time, and may not be available for travel. It is the policy of the county to construct a resilient transportation system so that when overtopping subsides, the infrastructure will be available for safe travel.

All roadways in Boulder County shall be evaluated with respect to stormwater runoff in accordance with the criteria in this MANUAL; specifically, Section 900 Roadways and Section 1000 Culverts and Bridges, shall apply to all roadways, including all private access roads, whether in the public right-of-way or not.

The policy of Boulder County shall be that all private access shall meet the criteria of this MANUAL.

307 ECOLOGICAL DESIGN

Ecological design, especially in channel restoration, has numerous public and environmental benefits when applied in an appropriate location. Ecological design components can be incorporated into almost all traditional engineering projects, but the design approach must balance ecological function with the need for channel stability.

The policy of Boulder County is to promote ecological design. The potential for every channel restoration project to include ecological components shall be discussed with the county during project planning. Ecological design will be incorporated.

308 SUMP PUMPS

Many homes and structures in the county have sump pumps located below the basement floor elevation that help to keep water out of the structures' basements. Shallow groundwater can result in consistent sump pump discharges to the ground surface. These flows can become problematic when there are not established locations for the sump pumps to discharge.

Locations that are not acceptable for sump pump discharge include sanitary sewers, privately owned adjacent property (without written permission), sidewalks, and curb and gutter sections. The county considers discharge of sump water to county roads to cause harm. Discharge to roadways will not be permitted. Acceptable locations include existing drainageways, existing public stormwater conveyance facilities excluding curb and gutter sections, and adjacent property with written approval from the owner. Discharge to raw water ditches or reservoirs as described in section 305 is allowable with the written permission of the facility owner(s). All sump discharge water must be free of all pollutants, including, but not limited to, solvents, pesticides, oil, and grease.

Where no acceptable location is immediately available, a pathway must be constructed to convey the sump discharge to the nearest acceptable location. This pathway may be constructed above ground as a roadside ditch or underground as a trenched pipeline. Boulder County must be consulted and approve of all sump drainage outfall construction that is located within county right-of-way. Written consent must be obtained from any raw water ditch or reservoir owner into which sump discharge is conveyed.

309 FLOODPLAIN MANAGEMENT

The county has adopted floodplain regulations that set forth the purpose, restrictions, and requirements for development within the regulatory floodplain. These regulations can be found in the CODE and are not repeated herein. They are considered policy for this MANUAL.

The policy of Boulder County regarding floodplain management shall be as set forth in the adopted floodplain regulations in the most recent version of the Boulder County Land Use Code and in the State floodplain regulations.

The floodplain regulations apply to all areas within the Floodplain Overlay District as defined in the most recent version of the CODE. There are specific provisions for the floodway, the flood fringe, and floodproofing. Floodplain regulations are discussed further in Section 1400 Environmental and Regulatory Permitting.

The Colorado Water Conservation Board issued *Rules and Regulations for Regulatory Floodplains in Colorado* (State floodplain regulations) on November 17, 2010. They can be found online (http://www.casfm.org/papers/Colorado_Floodplain_Rules_and_Regs_11-17-2010_Adopted.pdf) or via an internet search of "rules and regulations for regulatory floodplains in Colorado."

310 DETENTION

Local detention can reduce increased runoff rates caused by development to runoff rates that are closer to the historical or predevelopment rates. Regional detention can provide an even larger benefit by controlling a greater volume of storm runoff.

The policy of Boulder County is to require all new development and redevelopment to provide full-spectrum detention as set forth in Section 1200 Detention and Permanent Water Quality of this MANUAL.

311 WATER QUALITY

Stormwater runoff from developed areas is usually of poor quality. Pollutants in urban runoff may consist of all kinds of trash and debris, chemicals and salts from winter ice control, pesticides, herbicides, fertilizers, and bacteriological pollutants. Pollutants in rural runoff may include sand and silt, fertilizers, and bacteriological pollutants. Industrial runoff pollutants may consist of silts, oils, salts, and other chemicals.

The policy of Boulder County is to require all new development and redevelopment to provide permanent water quality treatment as set forth in Section 1200 Detention and Permanent Water Quality of this MANUAL.

312 MAINTENANCE

Storm drainage, storage, and water quality facilities will lose function over time if they are not maintained. Maintenance typically involves removal of debris and sediment from all kinds of stormwater facilities. Channel bank erosion, damage to drop structures, crushing of pipe inlets and outlets, and deterioration to the facilities must be repaired to avoid reduced conveyance capability, unsightliness, and failure. Maintenance access must be designed to facilitate maintenance activities.

Boulder County requires that maintenance access be provided to all drainage facilities. The property owner or homeowner's association shall be responsible for maintaining all drainage facilities unless modified by an agreement with Boulder County. Boulder County shall have the right to enter a property for the purpose of maintenance if the owner fails to do so. All such maintenance costs shall be reimbursed to Boulder County by the property owner.

The UDFCD provides an incentive program, called the Maintenance Eligibility Program (MEP), to encourage responsible design in developer-initiated floodplain modification projects. The UDFCD's Floodplain Management Program will review and comment on proposed development projects. Projects approved through the MEP process are eligible for UDFCD maintenance. Projects must meet the criteria contained in the UDFCD's USDCM as well as the Guidelines for Maintenance Eligibility.

It is the policy of Boulder County to pursue maintenance eligibility status from the Urban Drainage and Flood Control District for projects owned and operated by the county.

313 TRANSBASIN DIVERSIONS

Transferring the burden of managing runoff from one location or property to another is not equitable. Ongoing liability questions arise when the historic drainage patterns are altered. The diversion of runoff from one basin to another should be avoided. Planning and design of stormwater facilities should not be based on the premise that problems can be transferred from one location to another.

Changes to historic or natural drainage paths because of development within a major basin are generally acceptable provided the altered flow path continues to discharge back into the natural drainageway at or near the historic location. When runoff does not return to the historic drainageway, or returns at a rate higher than the historic rate, the basic civil drainage law principle of not discharging water onto a property in a manner or quantity that does more harm than formerly is violated.

The policy of Boulder County shall be to prohibit transbasin diversions of stormwater and to maintain the historic drainage path within the basin.

Section 400 Planning Table of Contents

401	INTRODUCTION	400-1
402	PLANNING PROCESS	400-2
403	PLANNING FOR STORMWATER MANAGEMENT	400-2
	403.1. Impacts of Potential Development	400-2
	403.2. Master Planning	400-3
	403.3. Maintenance Considerations	400-3
	403.4. Multiple Uses and Space Allocation	400-3
	403.5. Channel Stabilization and Ecological Design	400-3
	403.6. Low Impact Development	400-3
	403.7. Detention Ponds and Permanent Water Quality Facilities	400-4
404	UNIQUE SITE CONSIDERATIONS	400-4
	404.1 Water Rights and Raw Water Ditches	400-4
	404.2 Jurisdictional Dams and Reservoirs	400-4
	404.3 Groundwater	400-5

Section 400 Planning

401 INTRODUCTION

Storm drainage is a part of our overall environment, regardless of whether it is an urban or rural environment. The need for and function of stormwater facilities are often overlooked or dismissed by the public until a large storm event brings them to the forefront of the public awareness. While rural areas typically require less direct management of stormwater runoff than urban areas, small mountain streams in very rural areas can become raging rivers after a large storm or storm and snowmelt event.

Planning for stormwater management will be woven into overall development planning for both public and private facilities, and addressed early in the process. Failure to plan for stormwater management facilities at the earliest stages of development planning can lead to problems finding the space required to accommodate stormwater runoff; problems meeting regulatory requirements; facilities that are difficult to maintain; and, ultimately, a potentially higher infrastructure cost. When stormwater facilities are planned in advance as an integral part of development as a whole, they can be thoughtfully designed as public amenities to include functionality in addition to conveying water from one place to another. Stormwater facilities that are thoughtfully planned, especially open channels, can provide recreational opportunities, wildlife habitat, and visual interest. These facilities can also benefit downstream properties and drainageways through improved water quality and a more balanced sediment load.

Storm drainage is a regional phenomenon that affects all governmental jurisdictions and all parcels of property. What happens in one part of a watershed, or even an entire region, will have an effect in other parts of that watershed or region. This cause and effect drives the need to balance both public and private involvement and requirements. It is not effective to plan stormwater facilities for a single site without knowing the impacts to the larger system. Coordination and planning shall occur on a regional level.

The UDFCD has collaborated with communities within the UDFCD boundary, including Boulder County, to develop stormwater master plans for most of the watersheds within the UDFCD boundary. The UDFCD boundary and stormwater master plans that have been completed by the UDFCD can be found on their interactive website (<http://udfcd.gisworkshop.com/>) or via an internet search for "UDFCD mapping." Master planning efforts are requested by local governments and scheduled as part of a 4-year strategic plan. These plans identify locations with diminished water quality, determine appropriate flood risk management projects, identify the need for right-of-way acquisition, and provide justification for expenditure of funds for public improvements to storm drainage facilities that will enhance the general health and welfare of the region.

This section of the MANUAL focuses on several of the many facets of storm drainage design to consider before and during development and does not discuss specific planning submittal requirements for development review. Section 200 Submittals provides discussion on that topic. This section also does not discuss any of the many permits that are required late in the planning stages, including county,

state, and federal permits. These permits are discussed at length in Section 1400 Environmental and Regulatory Permitting.

402 PLANNING PROCESS

Because the impacts of stormwater can be far reaching geographically, drainage planning is a complex process. Several things will be considered during planning, but the general planning process is as follows:

1. **Major Drainage Planning.** This is the highest level of stormwater planning. Local and regional planning efforts will consider the major drainage system necessary to manage the 100-year runoff. Implementation of major drainage plans can reduce loss of life and major damage to the community and its infrastructure.
2. **Outfall System Planning.** Outfall system planning is watershed-based and identifies detention, water quality, and conveyance practices within a watershed. Outfall system plans typically address storm drain improvements, stream crossing improvements, increased conveyance, channel stabilization, and floodplain preservation.
3. **Initial Drainage System Planning.** This level of planning considers the drainage system required to transport runoff from the 2-year to 5-year storm events. Initial system planning will have the goal of minimizing drainage problems from these more frequently occurring storms.
4. **Water Quality and Environmental Design.** Stormwater planning efforts will address stormwater quality treatment, opportunities to mimic natural hydrology and preserve natural features, wildlife habitat, and the impacts of new facilities. A multi-disciplinary design team can help to ensure that all potential benefits are considered in the drainage planning effort.

403 PLANNING FOR STORMWATER MANAGEMENT

This section provides brief discussions regarding the general impacts of development and several factors that will be considered when planning stormwater management facilities.

403.1. Impacts of Potential Development

Development results in increased imperviousness and increased runoff rates and volumes. These increases can have significant impacts to downstream properties, existing natural channels, and infrastructure. Downstream properties can be flooded if increased runoff rates cannot be handled by existing stormwater facilities. Natural channels can experience extreme erosion due to the increased flow rates if corrective measures are not taken as development increases. Roads can be washed out if culverts and bridges are not upsized to accommodate the increases. Water quality often suffers with development as well. Sediment, nutrients, heavy metals, and trash and debris can all be associated with development. At a minimum, new infrastructure will be designed to accommodate future flow rates, as opposed to existing ones. Future flow rates are those that are anticipated to exist once full build-out of an area in accordance with proposed land use is complete.

403.2. Master Planning

Several master plans have been completed in Boulder County to define proposed drainageway improvements needed to address existing drainage problems or impacts of development. Future master plans and updates to existing master plans may be completed in the future. To ensure proposed development and new improvements to the overall storm drainage system will be compatible with plans for the surrounding areas, the county requires all improvements to be designed in accordance with adopted master plans and the criteria herein.

403.3. Maintenance Considerations

The function and effectiveness of many storm drainage and water quality facilities depends on adequate maintenance. Planning for maintenance activities must be included in the design of all stormwater management facilities, including providing space for personnel and equipment to access the facility from the nearest public road and limiting the need for maintenance by reducing the potential for sediment and debris to accumulate to the extent possible.

403.4. Multiple Uses and Space Allocation

Because stormwater management is part of the larger environment, space must be set aside to accommodate it. It may appear initially that providing space for stormwater management facilities such as channels and storage and water quality facilities is in direct competition with other land uses. However, not providing adequate space for stormwater facilities will ultimately disrupt the function of other land uses, especially during large storm events. Additionally, stormwater facilities can also be treated as a resource that provides recreational and social opportunities, wildlife habitat, visual interest, and water quality benefits. Facilities intended for use only during very large storm events, such as large or off-line storage facilities, can also accommodate sports and parks facilities when they are not being used for detention. Infiltration and detention can be incorporated into landscaped areas. At a minimum, right-of-way and easements will be included during the planning stages of development to ensure sufficient space is allotted to stormwater management.

403.5. Channel Stabilization and Ecological Design

Channel erosion often occurs with changes in hydrology because of development. The creek master plans adopted by Boulder County, the UDFCD, and other jurisdictions within the county provide preliminary design information regarding which channels require stabilization and how best to provide it. Even if the recommendations for stabilization do not currently involve ecological design concepts, these will be considered for all channel stabilization projects in the county to provide additional benefits, such as wildlife habitat and improvements to water quality. Ecological design concepts are discussed in Section 700 Open Channels. All improvements proposed must address the recommendations contained within the master plans adopted by the county. Work in channels will also consider impacts to regulatory floodplains and wetlands as part of the planning process.

403.6. Low Impact Development

The concept of Minimizing Directly Connected Impervious Areas (MDCIA) can contribute significantly to reducing runoff volume and peak flow rate and enhancing water quality. The concept is that the effective imperviousness of a site can be reduced by designing pervious areas, such as driveways, parking lots, and roofs, to discharge to pervious areas (such as grass buffers and swales) before discharging from a site. Impervious areas such as parking lots can also be broken into smaller individual

areas with pervious areas interspersed. This type of layout will slow the rate of runoff from a site and allow more opportunity for runoff from the impervious areas to infiltrate into the pervious areas. While using this strategy at a single site might not have a large effect on the watershed as a whole, low-impact development practices implemented routinely throughout a watershed can have a very large effect, especially on water quality. Additional information on low-impact development can be found in the USDCM.

403.7. Detention Ponds and Permanent Water Quality Facilities

Detention and permanent water quality facilities shall be sized and sited very early in the development planning process to ensure that side slopes can remain relatively flat. This will allow the facilities to be more easily maintained and to be incorporated into an overall site use plan that will allow them to be viewed as site amenities, rather than a necessary nuisance. The potential for infiltration will be evaluated. Local storm drains shall be incorporated into the functionality of the facility, and the design depth of the water in the detention or water quality facility will consider adjacent property use.

404 UNIQUE SITE CONSIDERATIONS

The considerations in this section occur much less frequently, but county staff and developers will determine if each of these items is applicable to the site being evaluated, as the impacts from these items can be extensive.

404.1 Water Rights and Raw Water Ditches

Drainage improvements must not affect water rights or the function of raw water ditches. The presence and potential impact of and to local head gates, raw water ditches, and reservoirs needs to be evaluated early in the planning process to determine appropriate measures required to avoid injuring water rights. Raw water ditch and reservoir owners must be contacted to determine what options are acceptable or impermissible prior to beginning design. Raw water ditches are not typically intended to convey stormwater runoff as transbasin diversions may occur; although, there are exceptions. Consent from the ditch owner(s) is required with the development application if the proposed improvements will alter flow patterns, quality, rates, or quantities to or within an existing raw water ditch.

404.2 Jurisdictional Dams and Reservoirs

There are over 100 jurisdictional dams in Boulder County, as defined by the Colorado Division of Water Resources Dam Safety Branch. Most are owned and operated by private irrigation companies, water districts, or municipalities, while a few are owned and operated by Boulder County Parks and Open Space. The CODE states that, "Land which is subject to a possible upstream dam failure shall not be platted unless the potential flooding condition is alleviated according to plans approved by the County Engineer, unless otherwise approved by the State Engineer." Development shall not be planned on lands that are subject to inundation by a dam breach without a design exception.

404.3 Groundwater

Groundwater can affect the function of stormwater management facilities, sump pumps, and other infrastructure. Prior to development, each site must be evaluated to determine potential impacts of groundwater. All designs shall accommodate or mitigate those impacts.

Groundwater may also increase with development and urbanization, often due to increased irrigation. Foundation drains and sump pumps are often used to collect and discharge these flows to the surface, often at locations that are not ideal. Icing or algae growth may result, which will affect the quality of life of local residents. During the planning stages of development, developers shall provide the county a discussion of potential groundwater impacts, such as impacts to wells, raw water ditches, and reservoirs, recommendations for solutions to mitigate those impacts, and a list of potentially impacted interests. The county's policy on groundwater discharge from sump pumps can be found in Section 308.

Any activities that result in the discharge, use, or handling of groundwater that are not addressed in this MANUAL shall be conducted in accordance with the State of Colorado's groundwater regulations. The state's regulations concerning groundwater are held at the following offices:

Colorado Department of Public Health and Environment, Water Quality Control Division – Domestic Ground Water Discharge Permit Program

Colorado Department of Natural Resources, Division of Water Resources – Ground Water Administration and Well Permitting

State of Colorado Ground Water Commission – Rules and Regulations for the Management and Control of Designated Ground Water

Colorado Department of Public Health and Environment, Water Quality Control Commission, Regulation No. 61 – Colorado Discharge Permit System Regulations (Section 61.14 Groundwater)

Colorado Department of Public Health and Environment, Water Quality Control Commission, Regulation No. 41 – The Basic Standards for Ground Water

Section 500 Rainfall Table of Contents

501 INTRODUCTION	500-1
502 INTENSITY-DURATION CURVES FOR RATIONAL METHOD	500-1
503 COLORADO URBAN HYDROGRAPH PROCEDURE RAINFALL HYETOGRAPHS.....	500-2
504 WATERSHED SIZE RAINFALL DISTRIBUTION ADJUSTMENTS	500-2
505 REFERENCES	500-3

List of Figures

500-1 Boulder County 5-Year 1-Hour Point Rainfall Depths	End of Section
500-2 Boulder County 5-Year 6-Hour Point Rainfall Depths	End of Section
500-3 Boulder County 100-Year 1-Hour Point Rainfall Depths	End of Section
500-4 Boulder County 100-Year 6-Hour Point Rainfall Depths	End of Section

Section 500 Rainfall

501 INTRODUCTION

The criteria for rainfall design presented in this section shall be used to calculate runoff using the accepted methodologies in Section 600. All detailed hydrologic analysis shall use the rainfall data presented herein for calculating storm runoff.

The National Oceanic and Atmospheric Administration (NOAA) published the *NOAA Atlas 2, Volume 3* (Atlas 2) in 1973 (NOAA, 1973). Atlas 2 was officially superseded by *NOAA Atlas 14* (Atlas 14) (NOAA, 2013) on April 19, 2013, for Colorado. The UDFCD then conducted a detailed evaluation of Atlas 14. While the point rainfall values in Atlas 14 are lower than those in Atlas 2, the Atlas 14 values were determined not to be statistically significantly different from the Atlas 2 values. Furthermore, nearly all infrastructure built in the last 40 years was based on the Atlas 2 values and has performed very well during flood events. The UDFCD ultimately determined continuing using point rainfall depths from Atlas 2 for hydrologic analysis in the Denver metro area was preferred. The UDFCD published a memorandum that details their findings (MacKenzie, 2013), which can be found on their website (http://udfcd.org/wp-content/uploads/uploads/resources/position%20papers/UDFCD_Position_on_the_2013_NOAA_Precipitation-Frequency_Atlas.pdf) or via an internet search for “UDFCD Atlas 14.”

Boulder County agrees with the assessment by the UDFCD, and Atlas 2 was used to develop 1-hour and 6-hour point rainfall maps for the 5- and 100-year return periods in the county. These point rainfall maps are presented in Figures 500-1 through 500-4, which is located at the end of this section. These maps are more detailed than those in the USDCM (UDFCD, 2016) and shall be used as long as the UDFCD continues to prefer Atlas 2 to Atlas 14. Equations for intensity and depth were taken from the USDCM. If revisions to these equations are included in future versions of the USDCM, those revisions shall apply.

502 INTENSITY-DURATION CURVES FOR RATIONAL METHOD

To develop depth-duration curves or intensity-duration curves for use with the Rational Method, the 1-hour point rainfall depths for the design storm shall be obtained from Figures 500-1 and 500-3, which are located at the end of this Section. Rainfall intensity can be calculated for a given duration using Equation 500.1. Equation 500.2 can be used to calculate total rainfall depths for durations less than one hour.

$$I = \frac{28.5P_1}{(10 + T_d)^{0.786}} \quad (500.1)$$

$$D = \frac{28.5P_1 (T_d / 60)}{(10 + T_d)^{0.786}} \quad (500.2)$$

where

I = rainfall intensity (inches/hour)

D = rainfall depth (inches)

P_1 = 1-hour point rainfall depth (inches)

T_d = storm duration or time of concentration (minutes).

503 COLORADO URBAN HYDROGRAPH PROCEDURE RAINFALL HYETOGRAPHS

The Colorado Urban Hydrograph Procedure (CUHP) requires 2-hour rainfall hyetographs to calculate stormwater runoff. The program will automatically create the necessary hyetographs using methodology calibrated to the metro Denver area. Hyetographs creation of requires the 1-hour point rainfall depth, which are available in Figures 500-1 through 500-4, located at the end of this section, as well as the return period for the design storm. CUHP will also create area-corrected hyetographs for project areas with a watershed greater than 10 square miles (see Section 504). The 6-hour point rainfall and watershed area in square miles are required to calculate an area-corrected hyetograph. Hyetographs with durations longer than 2 hours are automatically generated as required for area correction. Hyetographs generated by CUHP are recommended for most projects, but a user-defined hyetograph can be entered if required. The reader should refer to the CUHP users' manual for additional information.

504 WATERSHED SIZE RAINFALL DISTRIBUTION ADJUSTMENTS

Rainfall distributions for watersheds larger than 10 square miles need to be adjusted to account for rainfall not typically being evenly distributed over such a large area. The adjustment procedure is performed within CUHP on the Raingages worksheet. Any CUHP subcatchment draining to a design point with a total drainage area larger than 10 square miles must use an area-corrected rainfall distribution. Note that the requirement for area correction is determined at the design point level. CUHP subcatchment hydrographs that were created for a design point that requires area correction cannot be used for the analysis of a design point that either does not require area correction or requires a different amount of area correction. A large project with multiple design points may require multiple hydrologic models to account for the varying amounts of area correction that are required at different design points. Individual area-corrected rainfall distributions should typically be created each time a design point with a total drainage area changes by more than 10 square miles. For example, a unique rainfall distribution should be created for use with design points with a drainage area greater than 10, 20, 30, and 40 square miles, and so on; although, specific projects may require a higher degree of refinement.

505 REFERENCES

MacKenzie, K., 2013. *USFCD Position of the NOAA Atlas 14 Precipitation-Frequency Atlas, Volume 8*, memorandum prepared by K. Mackenzie, Urban Drainage and Flood Control District, Denver, CO.

National Oceanic and Atmospheric Administration, 2013. *Precipitation-Frequency Atlas of the United States, Midwestern States (Colorado, Iowa, Kansas, Michigan, Minnesota, Missouri, Nebraska, North Dakota, Oklahoma, South Dakota, Wisconsin)*, NOAA Atlas 14, Vol. 8, prepared by the National Oceanic and Atmospheric Administration, Washington, DC.

National Oceanic and Atmospheric Administration, 1973. *Precipitation-Frequency Atlas of the Western United States, Colorado*, NOAA Atlas 2, Vol. III, prepared by the National Oceanic and Atmospheric Administration, Washington, DC.

Urban Drainage and Flood Control District, 2016. *Urban Storm Drainage Criteria Manual: Volume 1 Management, Hydrology, and Hydraulics*, prepared by the Urban Drainage and Flood Control District, Denver, CO.

Figure 500-1 Boulder County 5-Year 1-Hour Point Rainfall Depths

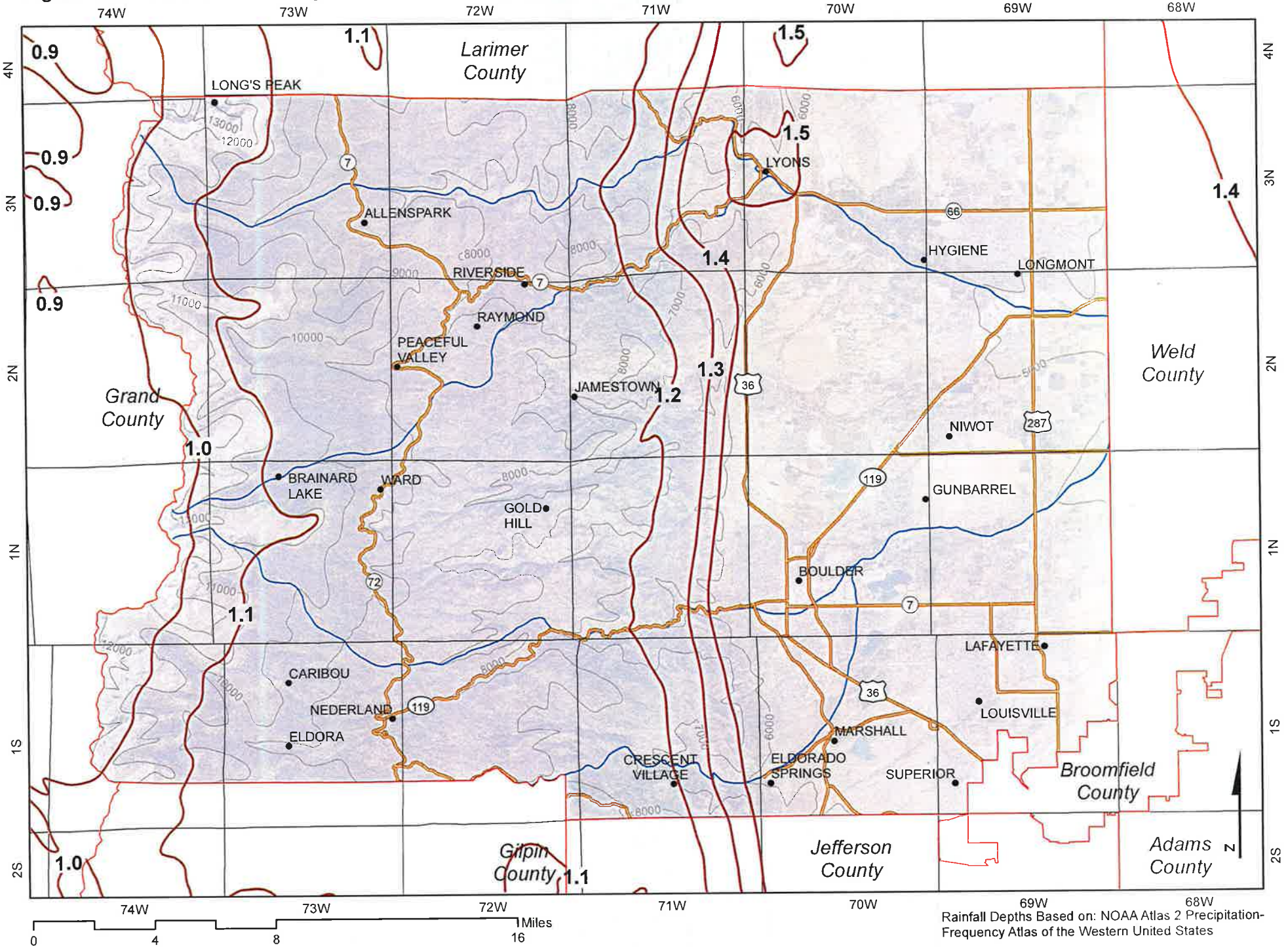

Rainfall Depths Based on: NOAA Atlas 2 Precipitation-Frequency Atlas of the Western United States

Figure 500-2 Boulder County 5-Year 6-Hour Point Rainfall Depths

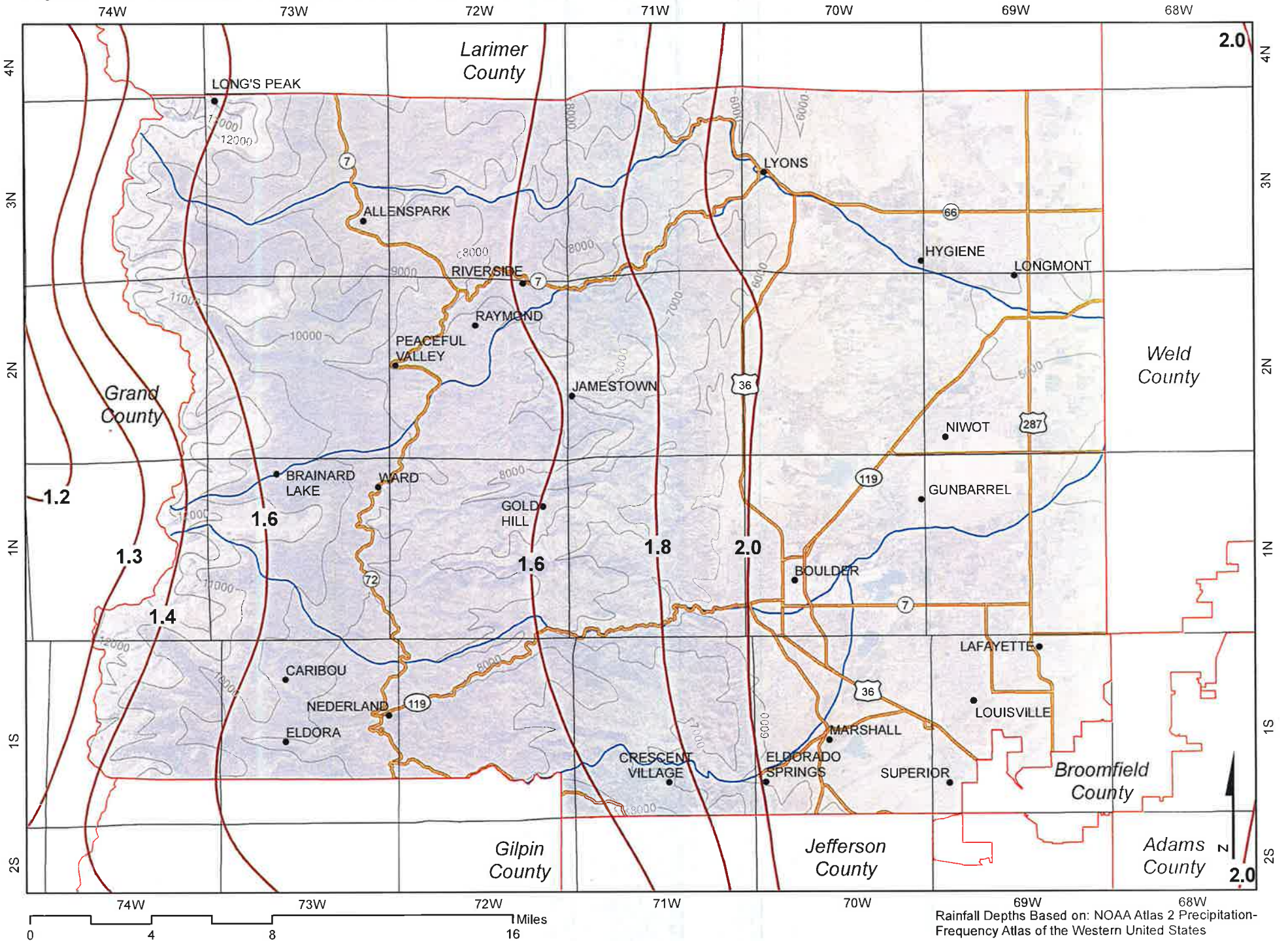

Rainfall Depths Based on: NOAA Atlas 2 Precipitation-Frequency Atlas of the Western United States

Figure 500-3 Boulder County 100-Year 1-Hour Point Rainfall Depths

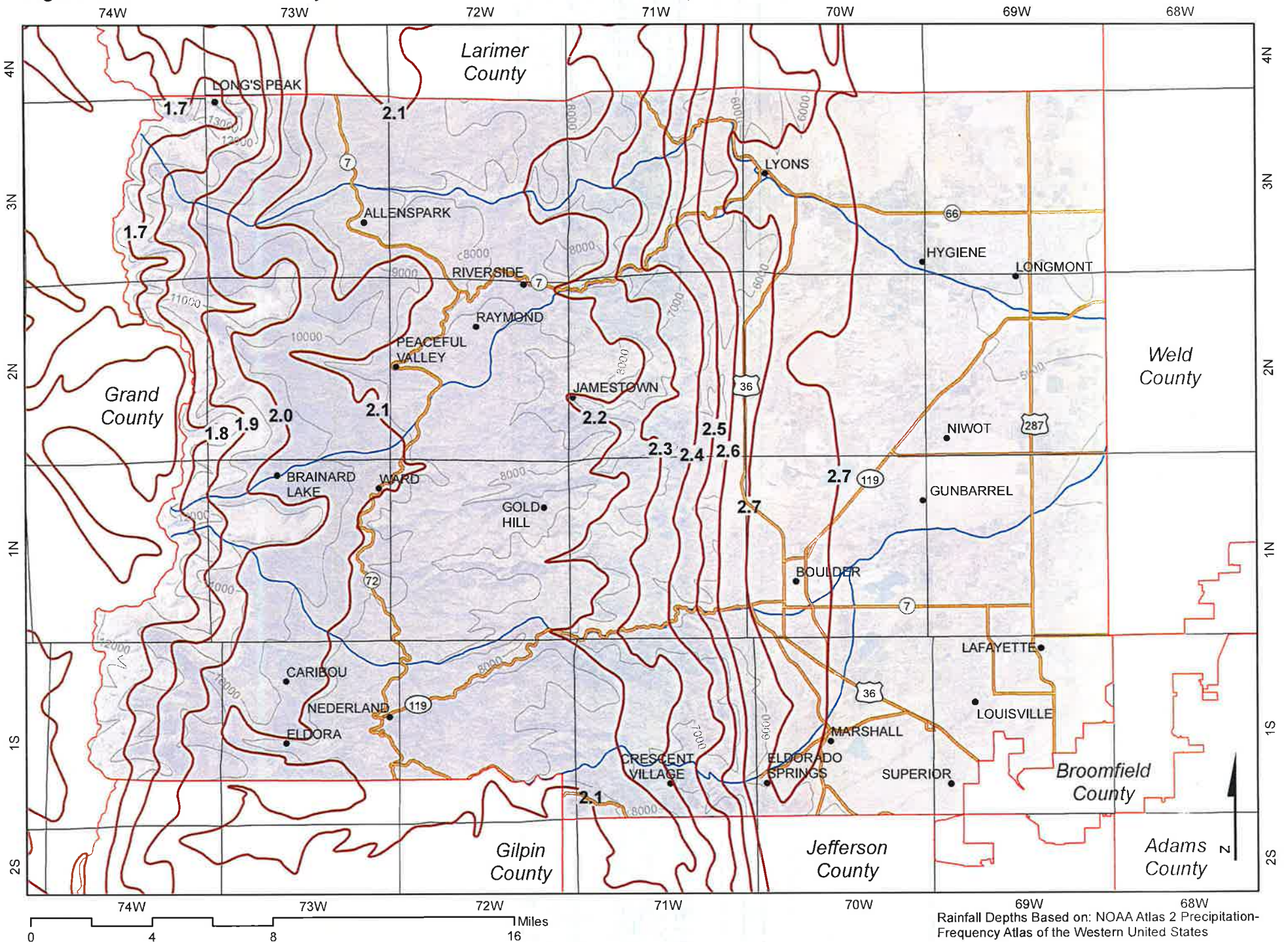

Rainfall Depths Based on: NOAA Atlas 2 Precipitation-Frequency Atlas of the Western United States

Figure 500-4 Boulder County 100-Year 6-Hour Point Rainfall Depths

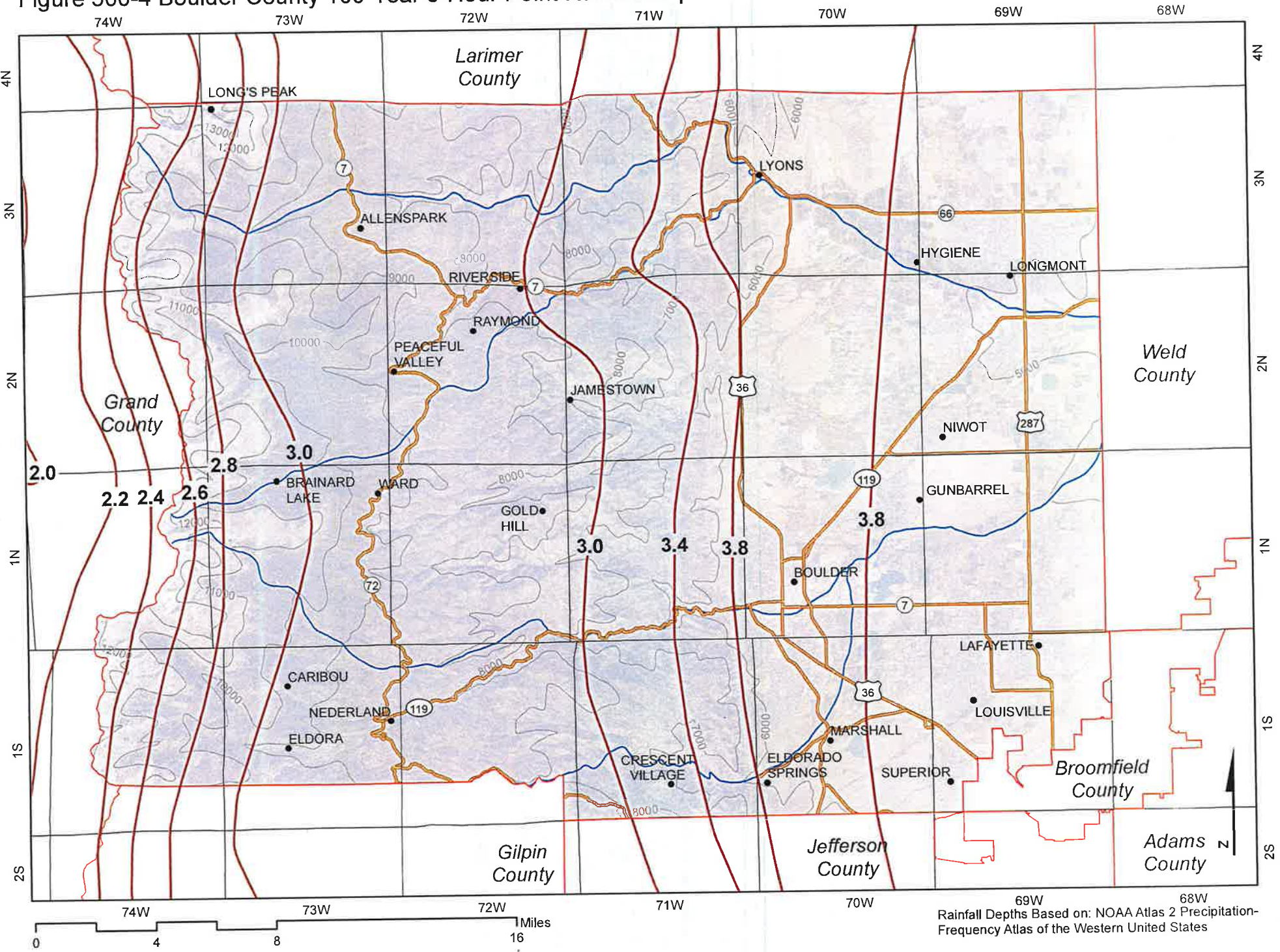

Rainfall Depths Based on: NOAA Atlas 2 Precipitation-Frequency Atlas of the Western United States

Section 600 Runoff Table of Contents

601	INTRODUCTION	600-1
602	RATIONAL METHOD	600-1
602.1	Rational Method Formula.....	600-2
602.2	Time of Concentration.....	600-2
602.3	Intensity	600-4
602.4	Runoff Coefficient.....	600-4
602.5	Basin Delineation	600-6
602.6	Major Storm Analysis.....	600-6
602.7	UD-Rational.....	600-6
603	COLORADO URBAN HYDROGRAPH PROCEDURE	600-7
603.1	Pervious and Impervious Areas	600-7
603.2	Depression Losses.....	600-7
603.3	Infiltration	600-8
603.4	Rainfall	600-8
603.5	Catchment Parameters	600-8
603.6	Catchment Delineation Criteria and Routing.....	600-9
604	STORM WATER MANAGEMENT MODEL	600-9
604.1	Routing.....	600-9
604.2	Routing Method.....	600-9
605	HYDROLOGIC MODELING SYSTEM	600-10
606	STREAMSTATS	600-10
607	REFERENCES	600-13

List of Tables

600-1	Conveyance Coefficient K.....	600-3
600-2	Recommended Percentage Imperviousness Values	600-5
600-3	Runoff Coefficient Equations Based on NRCS Soil Group and Return Period	600-6
600-4	Typical Depression Losses for Various Land Covers	600-7
600-5	Recommended Horton's Equation Parameter	600-8
600-6	Rational Method Runoff Coefficient, C	600-11

Section 600 Runoff

601 INTRODUCTION

This section will provide information and guidance on the five models approved to predict storm runoff: the Rational Method, the Colorado Urban Hydrograph Procedure (CUHP) developed by the UDFCD, the Storm Water Management Model created by the U.S. EPA (EPA-SWMM), the Hydrologic Modeling System by the U.S. Army Corps of Engineers Hydraulic Engineering Center (HEC-HMS), and StreamStats created by the USGS. All new development must use one of the first four methods to complete a detailed analysis unless published flows already exist. An exception will be made for a single-family dwelling, which may use StreamStats to estimate flow rates for design of a private driveway bridge or other drainage facilities.

For most large projects, CUHP will be used in conjunction with EPA-SWMM. For most small projects, the Rational Method will be used. The detailed computational techniques for these methods are presented in this section. The information contained in this section was largely adapted from the USDCM (UDFCD, 2016) for use in Boulder County. If the UDFCD revises the information below in future updates, those updates shall apply.

602 RATIONAL METHOD

For improvements with a total drainage area less than 90 acres, peak runoff may be calculated using the Rational Method. Despite its limitations, no other practical drainage design method has the same level of general acceptance. The Rational Method, when properly understood and applied, can produce satisfactory results for the design of urban storm drainage facilities.

One shortcoming of the Rational Method is that only one point on the runoff hydrograph is computed, the peak runoff rate. Projects that require a full runoff hydrograph will need to use CUHP or EPA SWMM. Another disadvantage is the difficulty of routing both the surface and piped flows where they have been separated by a storm sewer system. In general, this level of sophistication is not warranted, and a conservative assumption is made that the entire routing is in the storm drain system.

Finally, while the Rational Method can be used for basins up to 90 acres, this size limitation is for the sum of all the subbasins and not on the size of a single basin. The maximum size of any single basin should not exceed 15 acres for offsite flows analysis and 5 acres for onsite flow analysis. These subbasin sizes are based on typical gutter capacity for the onsite analysis and the minimum size storm drain for the offsite analysis.

602.1 Rational Method Formula

The formula for the Rational Method is shown in Equation 600.1.

$$Q = CIA \quad (600.1)$$

where

Q = peak discharge (cubic feet per second [ft^3/s])

C = runoff coefficient

I = average intensity of rainfall for a duration equal to the time of concentration (in/hr)

A = drainage basin area (acres)

The basic assumptions made when applying the Rational Formula are the following:

1. The computed maximum rate of runoff to the design point is a function of the average rainfall rate over the time of concentration to that point for the given return period.
2. The maximum rate of rainfall occurs during the time of concentration, and the design rainfall depth during the time of concentration is converted to the average rainfall intensity for the time of concentration.
3. The maximum runoff rate occurs when the entire area is contributing flow. However, this assumption has been modified from time to time when local rainfall/runoff data was used to improve calculated results.

602.2 Time of Concentration

One of the basic assumptions of the Rational Method is that runoff is a function of the average rainfall rate during the time required for water to flow from the most distant part of the drainage basin to the point under consideration. The time of concentration relationships in this section are based in part on rainfall-runoff data collected in the Denver area, and were developed in conjunction with the runoff coefficients that are also recommended in this section.

The time of concentration includes an overland travel time, t_i , and a channelized travel time, t_t , typically in a swale, storm drain, paved gutter, or channel. Overland travel time, also known as initial travel time, will vary with distance, surface slope, depression storage, surface cover, antecedent rainfall, and infiltration capacity of the soil. Channelized travel time can be estimated from the hydraulic properties of the swale, storm drain, gutter, or channel. The time of concentration is calculated using Equation 600.2 for both urban and non-urban areas.

$$t_c = t_i + t_t \quad (600.2)$$

where

t_c = time of concentration (minutes)

t_i = initial or overland travel time (minutes)

t_t = channelized travel time in a swale, storm drain, paved gutter, and channel (minutes).

Initial or overland travel time is calculated using Equation 600.3.

$$t_i = \frac{0.395(1.1 - C_s)\sqrt{L}}{S^{0.33}} \quad (600.3)$$

where

t_i = overland or initial flow time (minutes)

C_s = runoff coefficient for 5-year frequency from Table 600-6

L = length of overland flow (ft), 500 foot maximum for nonurban, 300 foot maximum for urban

S = average basin slope along the length of overland flow (ft/ft).

In some urban watersheds, the overland flow time may be very short as flows quickly channelize.

To calculate channelized travel time, the hydraulic properties of the swale, storm drain, paved gutter, or channel are first used to calculate flow velocity using Equation 600.4.

$$t_c = \frac{L_c}{60K\sqrt{S_0}} = \frac{L_c}{60V_c} \quad (600.4)$$

where

t_c = channelized travel time (minutes)

L_c = length of channel (ft)

K = conveyance coefficient from Table 600-1

S_0 = channel slope (ft/ft)

V_c = velocity (ft/sec).

Table 600-1. Conveyance Coefficient K (UDFCD, 2016)

Type of Land Surface	K
Heavy meadow	2.5
Tillage/field	5.0
Short pasture and lawns	7.0
Nearly bare ground	10
Grassed waterway	15
Paved areas and shallow paved swales	20

The total time of concentration can then be calculated by adding initial travel time to channelized travel time as shown in Equation 600.2.

For urban areas, the time of concentration calculated using Equation 600.2 should be checked against Equation 600.5 and the lesser time of concentration shall be used.

$$t_c = (18 - 15i) + \frac{L}{60(24i + 12)\sqrt{S_0}} \quad (600.5)$$

where

t_c = maximum time of concentration for an urban watershed (minutes)

L = combined length of overland and channelized flow (ft)

i = imperviousness (expressed as a decimal)

S_0 = slope of flow path (ft/ft).

Equation 600.5 was developed as part of a calibration study between the Rational Method and CUHP. Typically, Equation 600.5 will result in the lesser time of concentration and will govern in an urban environment. Furthermore, a minimum total time of concentration of 10 minutes should be used for non-urban watersheds, and a minimum total time of concentration of 5 minutes should be used for urbanized areas.

When using the Rational Method, it may be worth checking runoff peaks for multiple scenarios in each basin. Sometimes a lower portion of the catchment or areas of high imperviousness will produce a larger peak than is computed for the whole basin. This occurs most often when the basin is long or the upper portion contains grassy parkland and the lower portion is developed urban land.

602.3 Intensity

Rainfall intensity, I , is the maximum average rainfall rate in inches per hour for a duration equal to the time of concentration. Each return period will have a different intensity for a given time of concentration. After the design return period has been selected and the time of concentration has been calculated, Equation 500.1 can be used to determine the appropriate intensity. Refer to Section 500 for additional information.

602.4 Runoff Coefficient

The runoff coefficient, C , represents the effects of infiltration, evaporation, retention, routing, and interception, all of which affect peak runoff rates. The runoff coefficient varies by return period as well. The methodology to determine the runoff coefficient presented in this Section is adapted from the USDCM. The coefficients presented were calibrated for the Denver and Boulder area and may not be valid for use in other locations.

Runoff coefficients are influenced by soil type, imperviousness, and storm return period. Soil is categorized into four hydrologic groups by the NRCS – Types A, B, C, and D – based on water infiltration rates. Recommended imperviousness percentages, i , are listed in Table 600-2. Runoff coefficient equations are listed in Table 600-3 by soil type and storm return period. Note that imperviousness values from Table 600-2 must be converted to a decimal before being used to calculate runoff

coefficients. Runoff coefficients are also presented and organized by imperviousness, soil type, and return period in Table 600-6 at the end of this section.

Table 600-2. Recommended Percentage Imperviousness Values (UDFCD, 2016)

Land Use or Surface Characteristics	Percentage Imperviousness
<i>Business</i>	
Downtown areas	95
Suburban areas	75
<i>Residential</i>	
Single-family	
2.5 acres or larger	12
0.75 – 2.5 acres	20
0.25 – 0.75 acres	30
0.25 acres or less	45
Apartments	75
<i>Industrial</i>	
Light areas	80
Heavy areas	90
Parks, cemeteries	10
Playgrounds	25
Schools	55
Railroad yard areas	50
<i>Undeveloped Areas</i>	
Historic flow analysis	2
Greenbelts, agricultural	2
Off-site flow analysis (when land use is not defined)	45
<i>Streets</i>	
Paved	100
Gravel (packed)	40
Drive and walks	90
Roofs	90
Lawns, sandy soil	2
Lawns, clayey soil	2

Table 600-3. Runoff Coefficient Equations Based on NRCS Soil Group and Return Period (UDFCD, 2016)

NRCS Soil Type	Storm Return Period					
	2-Year	5-Year	10-Year	25-Year	50-Year	100-Year
A	$C_A = 0.89i$	$C_A = 0.93i$	$C_A = 0.94i$	$C_A = 0.944i$	$C_A = 0.95i$	$C_A = 0.81i + 0.154$
B	$C_B = 0.89i$	$C_B = 0.93i$	$C_B = 0.81i + 0.125$	$C_B = 0.70i + 0.23$	$C_B = 0.59i + 0.364$	$C_B = 0.49i + 0.454$
C/D	$C_{C/D} = 0.89i$	$C_{C/D} = 0.87i + 0.052$	$C_{C/D} = 0.74i + 0.2$	$C_{C/D} = 0.64i + 0.31$	$C_{C/D} = 0.54i + 0.418$	$C_{C/D} = 0.45i + 0.508$

where

i = imperviousness (expressed as a decimal) (see Table 600-2)

C_A = Runoff coefficient for NRCS Type A soils

C_B = Runoff coefficient for NRCS Type B soils

$C_{C/D}$ = Runoff coefficient for NRCS Type C and D soils.

602.5 Basin Delineation

The first step in applying the Rational Method is to delineate all subbasins using available contour and topographic data. Basins delineated by computer programs should have their boundaries verified. Basin delineations should include all area both tributary to and within the area of study. Field checks should be performed for each basin when feasible, or where available topography does not offer definitive boundaries.

The major storm drainage basin may not always coincide with the minor storm drainage basin. This is often the case in urban areas where minor storm flow may stay within a curb and gutter section, but a portion of the major storm flow will overtop the back of curb or street crown and flow into an adjacent subbasin.

602.6 Major Storm Analysis

Typical application of the Rational Method assumes that all of the runoff is collected by the storm sewer. For the minor storm design, the time of concentration is dependent upon the flow time in the sewer. However, during the major storm, storm drains will most likely be at capacity and will not be able carry the additional water flowing to the inlets. This additional water then flows overland past the inlets, generally at a lower velocity than the flow in the storm sewers. Using a separate time of concentration analysis for pipe flow and surface flow during the major storm event is acceptable but very complex and most likely not worth the effort. The simplified approach of using the minor storm time of concentration for all frequency analysis is acceptable for Boulder County.

602.7 UD-Rational

UD-Rational is a macro-enabled Microsoft Excel spreadsheet published by the UDFCD to assist with using the Rational Method. The spreadsheet can calculate the runoff coefficient, time of concentration, and rainfall intensity. The spreadsheet is available at the UDFCD website (www.udfcd.org).

603 COLORADO URBAN HYDROGRAPH PROCEDURE

CUHP is a method of hydrologic analysis based upon the unit hydrograph principle. It has been developed and calibrated using rainfall-runoff data collected in Colorado, mostly in the Denver and Boulder metropolitan areas. This section provides general background information on the use of the computerized version of CUHP to calculate runoff. Additional information on the various parameters discussed in this section can be found in the USDCM.

CUHP has been created as a Microsoft Excel based program by the UDFCD. The program is commonly used in conjunction with EPA SWMM to route flows from and through multiple subbasins, or subcatchments, to a common design point. The latest versions of CUHP and the associated users' manual are available on the UDFCD website (www.udfcd.org).

603.1 Pervious and Impervious Areas

The urban landscape comprises both pervious and impervious surfaces. The degree of imperviousness is the primary variable within the program that affects the total volume and rate of runoff. The estimated future imperviousness is typically used for design purposes. For subcatchments with nonhomogeneous imperviousness, the subcatchment area-weighted average imperviousness should be used. CUHP can also define the percentage of impervious area directly or indirectly connected to the drainage system and the percentage of pervious area that receives runoff from impervious areas. The CUHP users' manual contains additional information on this aspect of the program.

603.2 Depression Losses

Rainwater that is collected and held in small depressions and does not become part of the general surface runoff is called depression loss. Depression losses include water intercepted by vegetation and imperfections in pavement, roofs, or other surfaces. CUHP requires depression loss depths in inches to calculate runoff. Table 600-4, adapted from the USDCM, can be used as a guide for estimating depression losses to be entered into CUHP.

Table 600-4. Typical Depression Losses for Various Land Covers

Land Cover	Range	Recommended
<i>Impervious</i>		
Large paved areas	0.05–0.15	0.1
Roofs, flat	0.1–0.3	0.1
Roofs, slopes	0.05–0.1	0.05
<i>Pervious</i>		
Lawn grass	0.2–0.5	0.35
Wooded areas and open fields	0.2–0.6	0.4

Note: All values are in inches for use with CUHP.

603.3 Infiltration

The flow of water into the soil surface is called infiltration. NRCS soil type is the most important factor in determining the infiltration rate. Horton’s equation is used to model infiltration within CUHP and is described further in the USDCM. Recommended parameters for Horton’s equation are provided in Table 600-5, adapted from the USDCM.

Table 600-5. Recommended Horton’s Equation Parameter

NRCS Hydrologic Soil Group	Infiltration (inches/hour)		Decay Coefficient
	Initial	Final	
A	5.0	1.0	0.0007
B	4.5	0.6	0.0018
C	3.0	0.5	0.0018
D	3.0	0.5	0.0018

603.4 Rainfall

A 2-hour design storm is required to use CUHP. It can be created automatically within CUHP using the 1-hour point rainfall depth obtained in accordance with Section 500. When using an area-corrected rainfall distribution, the 6-hour point depth rainfall is also required. CUHP will then automatically create design storms longer than 2 hours as required for area correction. The user can also enter a previously created hyetograph.

603.5 Catchment Parameters

The following basin and hydrologic parameters are required by CUHP. The units listed are the defaults used by CUHP.

1. Area – Catchment area in square miles
2. Target Node – EPA SWMM node that corresponds to CUHP subcatchment; only required if using EPA SWMM in conjunction with the CUHP model
3. Raingage – CUHP design storm hyetograph
4. Length to Centroid – Distance in miles from the subcatchment outlet along the main drainageway path to the nearest point on the drainageway path to the subcatchment centroid
5. Length – Distance in miles from the subcatchment outlet along the main drainageway path to the furthest point of the subcatchment
6. Slope – Length-weighted, average slope of the subcatchment in feet per foot. Vegetated channels with slopes greater than 4 percent must be adjusted according to the procedure described in the USDCM
7. Percent Imperviousness – The portion of a subcatchment’s total surface area that is impervious, represented as a percent value between 0 and 100

8. Maximum Depression Storage – Pervious and impervious depression storage in inches
9. Horton's Infiltration Parameters – Initial infiltration rate (inches/hour), decay coefficient (dimensionless), and final infiltration rate (inches/hour) for soil within the subcatchment.

In addition to the parameters listed above, CUHP provides the user with optional overrides for C_T , C_i , C_p , hydrograph shape, directly connected impervious fraction, and receiving pervious fraction. The program can also verify that parameters are within recommended limits. The user should take advantage of this functionality to ensure results from the model are valid.

603.6 Catchment Delineation Criteria and Routing

The maximum size of a subcatchment is limited to 5 square miles. Whenever a larger subcatchment is studied, it should be subdivided into subcatchments of 5 square miles or less, and individual subcatchment storm hydrographs should be routed downstream using appropriate channel routing procedures such as those used by EPA SWMM. For areas less than 90 acres, a 1-minute time step should be used. The subcatchment shape can have a profound effect on the results and, in some instances, can result in underestimating peak flows. Irregularly shaped or very long subcatchments with a length-to-width ratio of four or more should be subdivided into more regularly shaped subcatchments. CUHP can create interface files that allow EPA SWMM to route subcatchment hydrographs, calculating a composite storm hydrograph at each design point. The CUHP users' manual provides information on calibrating the CUHP model, interfacing CUHP with EPA SWMM, and running multiple scenarios.

604 STORM WATER MANAGEMENT MODEL

EPA SWMM is a computer model that will generate surface runoff hydrographs from subcatchments and then route and combine those hydrographs. The program can also route and combine subcatchment hydrographs created by CUHP and is particularly useful for projects that require multiple CUHP subcatchments. EPA SWMM and the users' manual can be obtained from the EPA website (www.epa.gov/water-research/storm-water-management-model-swmm) or via an internet search for "EPA SWMM."

604.1 Routing

EPA SWMM consists of a network of open channels, pipes, and specialized units such as diversion nodes, storage units, and pumps. When modeling a project with storm sewers or culverts that are undersized for the design storm it is critical to include overflow links and diversions nodes in the model at locations with undersized infrastructure. Failure to do so may result in peak flows being underestimated. The output of the model should be carefully examined to determine if the capacity of any links are being exceeded.

604.2 Routing Method

Three hydrograph routing algorithms are available within EPA SWMM. They include steady flow, kinematic wave, and dynamic wave. The kinematic wave algorithm provides an acceptable degree of accuracy and is recommended for most projects in the county. Steady flow is the simplest routing strategy and translates inflow hydrographs to the downstream end with no delay or change in shape.

Steady flow routing will typically overestimate peak flows and is not recommended. Dynamic wave routing is theoretically the most accurate method but requires a more refined model and tends to be unstable when analyzing complex systems. For most projects, the increase in accuracy is minimal and does not justify the extra time and effort required to create a stable model. Dynamic wave routing is not recommended.

605 HYDROLOGIC MODELING SYSTEM

HEC-HMS provides much of the same functionality as EPA SWMM and can be used to generate surface runoff hydrographs from subcatchments and route the hydrographs along a drainage network. CUHP will not directly interface with HEC-HMS, as it will with EPA SWMM. The program and users' manual is available at the HEC website (<http://www.hec.usace.army.mil/software/hec-hms>) or via an internet search for "HEC-HMS software."

606 STREAMSTATS

StreamStats is a web-based application developed by the USGS that provides an assortment of hydrologic tools in a visual, map-based format. The application can delineate the drainage basin for a given design point and calculate hydrologic parameters, including area, slope, and estimated precipitation. A regression analysis can be performed to estimate peak flows for the 2-, 5-, 10-, 25-, 50-, 100-, 200-, and 500-year return periods. All of the equations in Colorado StreamStats are documented in the report titled *Regional Regression Equations for Estimation of Natural Streamflow Statistics in Colorado* (Capesius and Stephens, 2009), available at (<http://pubs.usgs.gov/sir/2009/5136/pdf/SIR09-5136.pdf>) or via an internet search for "USGS Report 2009–5136."

Predicted error is provided with peak flow estimates, and can frequently exceed 100 percent. Because of the high margin of error of estimated flows, this method is not a substitute for detailed hydrologic analysis. StreamStats is a useful tool for the hydrologic engineer, but any results from the application should be used with care and in consideration of the uncertainties of the results and an appreciation for the risks associated with the project. Availability of regression equations and peak flows is limited to hydrologic basins with parameters that are within certain limits. StreamStats is available online at (<http://water.usgs.gov/osw/streamstats/colorado.html>) or via an internet search for "USGS StreamStats Colorado."

Flows generated by StreamStats can be used in Boulder County only for designs related to a single-family residence where published flows do not exist. For all other development, a detailed analysis is required using one of the other methods discussed in this Section if published flows do not exist for a given project location.

Table 600-6. Rational Method Runoff Coefficient, C (Page 1 of 2) (UDFCD, 2016)

Percentage Imperviousness	2-Year	5-Year	10-Year	25-Year	50-Year	100-Year
Type A NRCS Hydrologic Soil Group						
2	0.02	0.02	0.02	0.02	0.02	0.17
5	0.04	0.05	0.05	0.05	0.05	0.19
10	0.09	0.09	0.09	0.09	0.10	0.23
15	0.13	0.14	0.14	0.14	0.14	0.28
20	0.18	0.19	0.19	0.19	0.19	0.32
25	0.22	0.23	0.24	0.24	0.24	0.36
30	0.27	0.28	0.28	0.28	0.29	0.40
35	0.31	0.33	0.33	0.33	0.33	0.44
40	0.36	0.37	0.38	0.38	0.38	0.48
45	0.40	0.42	0.42	0.42	0.43	0.52
50	0.45	0.47	0.47	0.47	0.48	0.56
55	0.49	0.51	0.52	0.52	0.52	0.60
60	0.53	0.56	0.56	0.57	0.57	0.64
65	0.58	0.6	0.61	0.61	0.62	0.68
70	0.62	0.65	0.66	0.66	0.67	0.72
75	0.67	0.70	0.71	0.71	0.71	0.76
80	0.71	0.74	0.75	0.76	0.76	0.80
85	0.76	0.79	0.80	0.80	0.81	0.84
90	0.80	0.84	0.85	0.85	0.86	0.88
95	0.85	0.88	0.89	0.90	0.90	0.92
100	0.89	0.93	0.94	0.94	0.95	0.96
Type B NRCS Hydrologic Soil Group						
2	0.02	0.02	0.14	0.24	0.38	0.46
5	0.04	0.05	0.17	0.27	0.39	0.48
10	0.09	0.09	0.21	0.30	0.42	0.50
15	0.13	0.14	0.25	0.34	0.45	0.53
20	0.18	0.19	0.29	0.37	0.48	0.55
25	0.22	0.23	0.33	0.41	0.51	0.58
30	0.27	0.28	0.37	0.44	0.54	0.60
35	0.31	0.33	0.41	0.48	0.57	0.63
40	0.36	0.37	0.45	0.51	0.60	0.65
45	0.40	0.42	0.49	0.55	0.63	0.67
50	0.45	0.47	0.53	0.58	0.66	0.70

Table 600-6. Rational Method Runoff Coefficient, C (Page 2 of 2) (UDFCD, 2016)

Percentage Imperviousness	2-Year	5-Year	10-Year	25-Year	50-Year	100-Year
55	0.49	0.51	0.57	0.62	0.69	0.72
60	0.53	0.56	0.61	0.65	0.72	0.75
65	0.58	0.60	0.65	0.69	0.75	0.77
70	0.62	0.65	0.69	0.72	0.78	0.80
75	0.67	0.70	0.73	0.76	0.81	0.82
80	0.71	0.74	0.77	0.79	0.84	0.85
85	0.76	0.79	0.81	0.83	0.87	0.87
90	0.80	0.84	0.85	0.86	0.89	0.90
95	0.85	0.88	0.89	0.90	0.92	0.92
100	0.89	0.93	0.94	0.94	0.95	0.94
Type C/D NRCS Hydrologic Soil Groups						
2	0.02	0.07	0.22	0.32	0.43	0.52
5	0.04	0.10	0.24	0.34	0.45	0.53
10	0.09	0.14	0.27	0.37	0.47	0.55
15	0.13	0.18	0.31	0.41	0.50	0.58
20	0.18	0.23	0.35	0.44	0.53	0.60
25	0.22	0.27	0.39	0.47	0.55	0.62
30	0.27	0.31	0.42	0.50	0.58	0.64
35	0.31	0.36	0.46	0.53	0.61	0.67
40	0.36	0.40	0.50	0.57	0.63	0.69
45	0.40	0.44	0.53	0.60	0.66	0.71
50	0.45	0.49	0.57	0.63	0.69	0.73
55	0.49	0.53	0.61	0.66	0.72	0.76
60	0.53	0.57	0.64	0.69	0.74	0.78
65	0.58	0.62	0.68	0.73	0.77	0.80
70	0.62	0.66	0.72	0.76	0.80	0.82
75	0.67	0.70	0.76	0.79	0.82	0.85
80	0.71	0.75	0.79	0.82	0.85	0.87
85	0.76	0.79	0.83	0.85	0.88	0.89
90	0.80	0.83	0.87	0.89	0.90	0.91
95	0.85	0.88	0.90	0.92	0.93	0.94
100	0.89	0.92	0.94	0.95	0.96	0.96

607 REFERENCES

Capesius, J. P. and V. C. Stephens, 2009. *Regional Regression Equations for Estimation of Natural Streamflow Statistics in Colorado*, Scientific Investigations Report 2009–5136, prepared by the U.S. Geological Survey, Reston, VA.

Urban Drainage and Flood Control District, 2016. *Urban Storm Drainage Criteria Manual: Volume 1 Management, Hydrology, and Hydraulics*, prepared by the Urban Drainage and Flood Control District, Denver, CO.

Section 700 Open Channels

Table of Contents

701	INTRODUCTION	700-1
702	HYDRAULICS OF OPEN CHANNELS	700-1
702.1	Uniform Flow	700-1
702.2	Critical Flow	700-2
702.3	Gradually Varied Flow	700-3
702.4	Rapidly Varied Flow	700-3
703	OPEN CHANNEL DESIGN STANDARDS	700-4
704	ROADSIDE DITCH DESIGN STANDARDS	700-7
705	REFERENCES	700-8

List of Figures

700-1	Typical Natural Stream	700-5
-------	------------------------------	-------

List of Tables

700-1	Manning Roughness Coefficients	700-2
700-2	Ecological Treatment Advantages and Disadvantages	700-5
700-3	Allowable Velocity and Froude Number for Roadside Ditches	700-8

Section 700 Open Channels

701 INTRODUCTION

Water that is conveyed so that the top surface is exposed to the atmosphere is defined as open channel flow. Open channel flow occurs in streams, rivers, canals, drainage channels, and roadside ditches as well as in conduits such as culverts and storm drains that are not flowing full. This section discusses open channel flow and presents criteria to be used for hydraulic design and evaluation of open channels, including roadside ditches. Any work in natural channels may be subject to the restrictions of Boulder County and FEMA floodplain regulations. Section 1400, Environmental and Regulatory Permitting discusses the permits that will be required for work in channels.

For a thorough discussion of open channel design principles, the user is encouraged to review the most recent version of the USDCM (UDFCD, 2016). Many other excellent references are available, including Chow (1959) and King and Brater (1963).

702 HYDRAULICS OF OPEN CHANNELS

The hydraulics of an open channel can be complex, ranging from steady state uniform flow to unsteady, rapidly varied flow. Most drainage design involves uniform, gradually varied, or rapidly varied flow states. Steady uniform flow occurs when the depth of flow remains constant. The calculations for both uniform and gradually varied flow are relatively simple and are based on the assumption of parallel streamlines. By contrast, rapidly varied flow calculations, which are used for things like hydraulic jumps and flow over spillways, have solutions that are generally empirical in nature. This section presents basic equations and computational procedures for uniform, gradually varied, and rapidly varied flow for hydraulic jumps and weirs.

702.1 Uniform Flow

Open channel flow is considered uniform if the depth of flow is the same at every section of the channel. For a given channel geometry, roughness, discharge, and slope, there is only one possible depth for maintaining uniform flow. This is called the normal depth. For a prismatic channel cross section, the water surface will be parallel to the channel bottom during uniform flow. Uniform flow rarely occurs in nature and is difficult to achieve, even in a laboratory. However, channels are designed by assuming uniform flow as an approximation that is adequate for planning purposes.

Calculations for normal flow depth shall be based on Manning's equation shown as Equation 700.1. A spreadsheet is an effective tool for quick analysis.

$$Q = \frac{1.49}{n} A^{5/3} P^{-2/3} \sqrt{S} = \frac{1.49}{n} AR^{2/3} \sqrt{S} \tag{700.1}$$

where:

- Q = flow rate (ft³/s)
- n = Manning roughness coefficient
- A = area (ft²)
- P = wetted perimeter (ft)
- R = hydraulic radius = A/P (ft)
- S = slope of the energy grade line (ft/ft).

For prismatic channels with uniform flow, the slope of the energy grade line (EGL), hydraulic grade line (HGL), and bottom of channel can be assumed to be equal. Table 700-1 provides recommended Manning roughness coefficients for various channel conditions. As the roughness increases, a given flow rate will have a greater depth and slower velocity. Conversely, a lesser roughness results in shallower depth and faster velocity. Selection of roughness coefficients for both the main channel and the overbanks is a critical part of the design and evaluation of an open channel.

Table 700-1. Manning Roughness Coefficients (modified from UDFCD, 2016)

Location and Cover	For Velocity, Froude Number, and Shear Stress Calculations	For Water Surface Elevation and Depth Calculations
<i>Main Channel</i>		
Sand or clay bed	0.03	0.04
Gravel or cobble bed	0.035	0.07
Troweled concrete	0.012	0.015
<i>Vegetated Overbanks</i>		
Turfgrass sod	0.03	0.04
Native grasses	0.032	0.05
Herbaceous wetlands (few to no willows)	0.06	0.12
Willow stands, woody shrubs	0.07	0.16

702.2 Critical Flow

Critical flow in an open channel is characterized by the following conditions:

1. The specific energy is at a minimum for a given discharge.
2. The discharge is at a maximum for a given specific energy.
3. The specific force is at a minimum for a given discharge.

4. The velocity head is equal to half the hydraulic depth in a channel with a minimal slope.
5. The Froude Number (Fr) is equal to 1.0.

When critical flow exists for uniform flow, the channel slope is at the critical slope. A slope flatter than critical will cause subcritical flow and result in a Froude number smaller than 1.0. A slope steeper than critical will cause supercritical flow and result in a Froude number larger than 1.0. When flow is at or near critical, it is unstable because minor changes in specific energy, such as from channel debris, will cause a major change in depth. The Equation 700.2, used to calculate the Froude Number, should be used to check flow state for all open channel designs.

$$Fr = \frac{v}{\sqrt{gD_h}} \quad (700.2)$$

where:

Fr = Froude number (dimensionless)

v = velocity (ft/s)

g = gravitational acceleration (32.2 ft/s²)

A = channel flow area (ft²)

T = top width of flow area (ft)

D_h = hydraulic depth, $D_h = A/T$ (ft).

702.3 Gradually Varied Flow

The most common occurrence of gradually varied flow in storm drainage design is the backwater created by culverts, inlets, and channel constrictions. For these conditions, flow depth will be greater than normal depth in the channel and the water surface profile must be computed using a backwater technique—either the direct step or the standard step method. The direct step method is best suited to the analysis of simple prismatic channels, whereas the standard step method is best suited for irregular or nonuniform cross-sections. The most general and widely used program is currently HEC-RAS, developed by the U.S. Army Corps of Engineers. HEC-RAS is recommended for calculating water surface profiles in Boulder County. If a designer would like to compute water surface profiles by hand, the methodology for using both the direct-step and standard-step methods can be found in the HEC-RAS *Hydraulic Reference Manual* (Brummer, 2010), as well as in *Open Channel Hydraulics* (Chow, 1959).

702.4 Rapidly Varied Flow

Rapidly varied flow is characterized by very pronounced curvature of the streamlines. The change in curvature may become so abrupt that the flow profile is virtually broken, resulting in a state of high turbulence. Several common instances of rapidly varied flow include weir flow, orifice flow, and hydraulic jumps. Only hydraulic jumps will be discussed in this section. In Boulder County, weir and orifice flow are used almost exclusively for detention pond outlets and will be discussed in Section 1200, Detention and Permanent Water Quality.

Hydraulic jumps may occur at grade control structures, inside storm drains or culverts, and at the outlet of a spillway and can be very erosive and affect hydraulic capacity. For grassed channels, the forces from a hydraulic jump must be controlled to prevent serious damage. Drops or other grade control structures can be used to direct the jump to an area specifically designed to resist the forces that come with it.

Jump locations within storm drain systems can be approximated by intersecting the energy grade line of the supercritical and subcritical flow reaches. Because storm drain velocity is limited to 16 feet per second, and because all storm drains in the county are required to be concrete, little threat of damage exists, but pipe capacity may be impacted. The effect on pipe capacity can be determined by evaluating the energy grade line and taking into account the energy lost by the jump. In general, for Froude Numbers less than 2.0, energy loss is less than 10 percent.

For long concrete boxes, the concerns of the jump are the same as for storm drains. However, the jump can be adequately defined for box conduits and for spillways using the jump characteristics of rectangular sections. A detailed evaluation of the hydraulic jump is beyond the scope of this MANUAL, but design procedures are provided in Chow (1959) and Peterska (1978). The UDFCD's USDCM also has procedures and calculations that can be used. Calculations must be included with the required submittals in accordance with Section 200.

703 OPEN CHANNEL DESIGN STANDARDS

The design standards for all open channels in the county, with the exception of roadside ditches, are the same as those in the most recent edition of the USDCM. The design process for an open channel can be somewhat circular because of a wide range of options available for materials, typical cross section, channel slope, and the prevalence of drop structures. The design components that have the greatest potential effect on the performance and cost of the improvements should be evaluated early on to guide the design process. Design considerations include allowable velocity, required capacity, curvature limitations, right-of-way constraints, structures such as bridges or culverts, maintenance access, access and safety of recreational users including boaters, and the desire for ecological components to be included in the design. Figure 700-1 shows an example of the typical natural stream in Boulder County.

The USDCM offers guidance on channel centerline and cross section layout, hydraulic analysis, and using rocks and boulders for protection from erosion. The USDCM also puts a considerable amount of emphasis on preserving and restoring natural stream corridors. Boulder County is a strong proponent of the use of ecological concepts to preserve and restore our local channels. Ecological channel design includes bioengineering practices that utilize vegetation in a combination with natural structural measures to stabilize and protect stream banks while providing habitat for a number of species. Master plans often specify where ecological treatments have already been approved for use and are expected to be constructed.

Ecological design can have numerous public and environmental benefits when applied in an appropriate location, but care should be taken in selecting the location and completing the design calculations to ensure an ecological design will hold up under the stream forces it is intended to withstand. Numerous

types of bioengineering components can be used in Boulder County. General schematic details of the bioengineering components that have been approved for use by the county are included as an appendix to this MANUAL. Table 700-2 lists some of the potential advantages and disadvantages to using an ecological channel design, as opposed to the more traditional riprap and concrete design concepts. Boulder County is a strong proponent of using ecological design concepts to restore channels damaged by flood events, with particular emphasis on reaches where riparian vegetation was destroyed. The potential for every channel restoration project to include ecological components shall be examined and discussed with the county.



Figure 700-1. Typical Natural Stream (Boulder County, 2016).

Table 700-2. Ecological Treatment Advantages and Disadvantages

Advantages	Disadvantages
Environmental clearances (may facilitate permits)	Potentially more expensive
Aesthetically pleasing	Specialized vegetation
Fish passage	Additional maintenance required
Habitat for fish, birds, and macroinvertebrates	Susceptible to failure during larger storms
Open space creation and preservation	May require a larger footprint
Water temperature moderation	Specific hydrologic conditions required
Water quality enhancement	

Ecological channel design may be applied when the overall channel design is firmly rooted in engineering principles and when the following conditions are met:

1. Hydrologic conditions are favorable for establishment and successful growth of vegetation.
2. Designs are conservative in nature, and bioengineered features are used to provide redundancy.
3. Maintenance responsibilities are clearly defined.
4. Adequate structural elements are provided for stable conveyance of the major storm runoff.
5. Species are selected based on individual site characteristics.

It is important to note that bioengineered elements are commonly designed to withstand flows from more frequently occurring storms. Design events are typically between the 1.5-year to 10-year storm, with the 100-year storm occasionally being a consideration. While designing for a larger event is prudent, stability during such events may often be achieved by traditional engineering techniques because bioengineered elements may not remain stable above a certain threshold. If stability is critical at a given location, such as at bridge piers or near a structure, bioengineering measures may not provide sufficient stability on their own, without the addition of traditional engineering techniques. Bioengineering techniques can be incorporated into almost all traditional engineering projects, often to great ecological benefit. The design approach must balance ecological function with the need for channel stability when selecting a design discharge. If a channel segment is expected to withstand the 100-year event, it needs to be designed to meet that criterion, regardless of the techniques used. Both the county and the design engineer should discuss and agree upon the various ecological and hydraulic criteria the design will meet.

The key elements to consider in an ecological channel design include hydrology, hydraulics, geomorphology, physiochemistry, and biology. Each of the following elements should be addressed when designing the channel.

1. Future hydrologic changes associated with urbanization
2. Channel Stability
3. Hydrology to support vegetation
4. Supplemental structural measures.

The USDCM should be reviewed as part of the design process because it offers valuable guidance on typical minimum standards. The Natural Channel Design Review Checklist published by the US Fish and Wildlife Service should also be reviewed to ensure that all appropriate parameters have been considered.

No specific criteria or design guidance is included in this MANUAL because each site is unique and will require a solution based on the goals for each site. However, there are publications that offer guidance on ecological channel design, and these should be consulted to ensure the design will stand up to the chosen design hydraulic event. The Technical Supplements contained in *Stream Restoration Design* (National Engineering Handbook 654) (NRCS, 2007), offer extensive and detailed guidance on physical design of ecological channels. Specifically, Technical Supplements 14I through 14O offer design guidance and equations for soil bioengineering, using large woody material for habitat and bank protection, vegetated rock walls, fish passage, and fish lunkers, among many other components.

Monitoring and maintenance should be performed throughout the life of the ecological channel design. The following list consists of four periods when a bioengineered structure is most at risk:

1. Immediately after construction
2. During the driest time of the year
3. During high magnitude discharge events
4. When a shift in plant community occurs away from plants chosen for biostabilization.

To achieve the highest likelihood of establishment of the specified vegetation, a 3-year maintenance plan from a certified landscaping company that understands native vegetation will be required. If seed is used, Boulder County Parks and Open Space shall be consulted to provide a site-specific seeding mix for each project. Plantings need to be completed in the fall or late winter to provide the best odds of establishment. Depending on the site, irrigation may also be required. Other techniques to improve the odds of successful vegetation establishment include the following:

1. Pretreating the project site to remove invasive or noxious species
2. Selecting an appropriate and diverse early-seral seed mix with the potential to fully occupy the site's botanical niches
3. Adequate seeding rate and seeding techniques coupled with soil amendments as determined by proper soil testing
4. Minimizing or eliminating the use of nitrogen, because exotic weeds are often preferentially stimulated over native species
5. Monitoring the nontarget species and noxious weed seeds that are often present in a seed mix
6. Developing an iterative weed management plan based on regularly scheduled monitoring.

704 ROADSIDE DITCH DESIGN STANDARDS

Much like the design of any open channel, design of roadside ditches is a balance of several design components, including velocity, capacity, available right-of-way, slope, and cross-sectional geometry. A wide range of roadside ditch geometry is allowed in the county. Section 900, Roadways, discusses several constraints and factors to consider when laying out a roadside ditch. The capacity requirements of a roadside ditch are based on roadway encroachment, also discussed in Section 900.

This section discusses permissible velocities and Froude numbers when designing a roadside ditch. Roadside ditch hydraulic calculations will be completed using Manning's equation. The Manning's roughness coefficients for calculating velocity, Froude number, and shear stress included in Table 700-1 will be used for all roadside ditch calculations, including capacity and water surface elevation. The designer should note that if a ditch is expected to be vegetated, there is a much higher potential for erosion until vegetation is complete. The use of erosion control measures prior to revegetation will minimize this potential.

Roadside ditch flow with depths less than or equal to 1.0 feet have no Froude number or velocity limitations. For ditch flow depths greater than 1.0 feet, velocity shall not exceed 7.0 feet per second, and the Froude number shall not exceed 0.8. These criteria are shown in Table 700-3.

Table 700-3. Allowable Velocity and Froude Number for Roadside Ditches

Design Component	Maximum Allowable Values	
	Flow Depth ≤ 1.0 feet	Flow Depth > 1.0 feet
Velocity	No maximum	7 fps
Froude Number	No maximum	0.8

Where roadway slopes are steep enough to result in ditch slopes that are too steep for ditch velocities or Froude numbers to meet criteria, a flattened ditch slope may be used with ditch checks placed at intervals to make up for grade discrepancies. An example of a ditch check is in Section 1100, Hydraulic Structures.

705 REFERENCES

Brummer, G., 2010. *HEC-RAS River Analysis System Hydraulic Reference Manual*, prepared by the U.S. Army Corps of Engineers, Hydrologic Engineering Center (HEC), Davis, CA.

Chow, V. T., 1959. *Open Channel Hydraulics*, McGraw-Hill College, Burr Ridge, IL.

King, H. W. and E. F. Brater, 1963. *Handbook of Hydraulics for the Solution of Hydrostatic and Fluid-Flow Problems*, McGraw-Hill, New York, NY.

Natural Resources Conservation Service, 2007. *Part 654 National Engineering Handbook Stream Restoration Design*, prepared by the Natural Resources Conservation Service, Washington, DC.

Peterska, A. J., 1978. "Hydraulic Design of Stilling Basins and Energy Dissipators," Engineering Monograph No. 25, U.S. Department of the Interior, U.S. Bureau of Reclamation, Washington, DC.

Urban Drainage and Flood Control District, 2016. *Urban Storm Drainage Criteria Manual: Volume 1 Management, Hydrology, and Hydraulics*, prepared by the Urban Drainage and Flood Control District, Denver, CO.

Section 800 Storm Drains

Table of Contents

801 INTRODUCTION.....	800-1
802 DESIGN CRITERIA	800-1
802.1 Design Storm Frequency	800-1
802.2 Construction Materials.....	800-1
802.3 Horizontal and Vertical Alignment	800-1
802.4 Pipe Size.....	800-2
802.5 Storm Inlets	800-2
802.6 Storm Drain Capacity and Velocity.....	800-2
802.7 Storm Drain Outlets.....	800-3
803 HYDRAULICS OF STORM DRAINS	800-3
803.1 Manual Hydraulic Calculations.....	800-3
803.2 Hydraulic Calculations Using a Computer Model.....	800-3
803.2.1 Rational Method.....	800-4
803.2.2 Bend and Lateral Loss Coefficients	800-4
804 HYDRAULICS OF STORM INLETS.....	800-4
804.1 Introduction.....	800-4
804.2 Inlet Capacity.....	800-4
804.3 Continuous Grade Condition	800-5
804.4 Sump Condition	800-5
804.5 Inlet Spacing	800-5
804.6 Inlet Grates	800-6
805 DESIGN OF STORM DRAIN SYSTEM	800-6
805.1 Preliminary Design.....	800-6
805.2 Final Design	800-7
806 REFERENCES.....	800-8

List of Tables

800-1 Manning's <i>n</i> Values for Capacity and Velocity.....	800-2
--	-------

Section 800 Storm Drains

801 INTRODUCTION

The criteria presented in this section shall be used to design and evaluate storm drain systems in Boulder County. "Storm drain system" refers to the system of inlets, pipes, manholes or junctions, outlets, and other appurtenant structures that are designed to collect and convey the minor storm runoff and discharge it to a major drainage system. The storm drain system is a part of the local drainage system, which may also include curb and gutter, streets, roadside ditches, swales, and channels. This section presents both technical criteria and the general procedure for design and evaluation of pipes and inlets. Allowable roadway encroachment is discussed in Section 900, Roadways.

802 DESIGN CRITERIA

802.1 Design Storm Frequency

A storm drain system is required when the allowable street capacity is exceeded during the 5-year event.

802.2 Construction Materials

Pipes, materials, and related items that are suitable for roadway cross culverts in accordance with Section 1000 are also suitable for storm drain systems. These requirements limit pipe materials to reinforced concrete.

802.3 Horizontal and Vertical Alignment

Storm drains shall be designed with enough cover to support the vehicular bridge loadings listed in the Boulder County Multimodal Standards and with the pipe manufacturer's recommendations. The minimum cover shall be 12 inches. Trench installations shall be in accordance with the most recent edition of the CDOT M&S Standard Plans. Manholes will be required whenever there is a change in size, vertical or horizontal alignment, elevation, grade, and at all junctions.

The minimum clearance between a storm drain and a water main shall be 12 inches, regardless of which is higher. Concrete encasement or bridging of the water line will be required for clearances of 12 inches or less. The work shall be in accordance with the CDOT M&S Standard Plans, Boulder County Standard Drawings, or other approved details, and the design must be approved by both the county and the utility owner.

The minimum clearance between a storm drain and a sanitary sewer shall also be 12 inches. When a sanitary sewer lies above a storm drain, the sanitary sewer shall have an impervious encasement or be constructed of structural drain pipe for a minimum of 10 feet on each side of where the storm drain crosses. When a sanitary sewer is below a storm drain and has less than 18 inches clearance, concrete encasement or bridging of the sanitary line will be required. The work shall be in accordance with the

CDOT M&S Standard Plans, Boulder County Standard Drawings, or other approved details, and the design must be approved by both the county and the utility owner.

Storm drain alignment between manholes shall be straight. Manholes shall be spaced no more than 400 feet apart for trunk lines 36 inches in diameter and smaller and 500 feet for trunk lines larger than 36 inches in diameter.

802.4 Pipe Size

Storm drain trunk lines shall have a minimum diameter of 18 inches or the hydraulic equivalent if using a shape other than circular. Storm drain laterals from inlets shall have a minimum diameter of 15 inches or the hydraulic equivalent if using a shape other than circular.

802.5 Storm Inlets

The standard inlets permitted for use in Boulder County streets are a CDOT Type R curb opening inlet, a CDOT Type C grated inlet, and a Denver Type 16 combination inlet. Type R and Type 16 inlets shall be used with a 6-inch vertical curb and gutter section, and Type C inlets shall be used in roadside ditches. Type C inlets shall be installed in accordance with the CDOT standard plans, including creating a sump condition where one does not naturally exist.

802.6 Storm Drain Capacity and Velocity

The storm drain system shall be designed to convey the minor storm without resulting in pressure flow. The minor storm capacity and velocity shall be calculated using the Manning’s *n* values in Table 800-1.

Table 800-1. Manning’s *n* Values for Capacity and Velocity

Pipe Material	Manning’s <i>n</i> Value	
	Capacity Calculation	Velocity Calculation
RCP (newer)	0.013	0.011
RCP (older)	0.015	0.012
RCP (preliminary design)	0.015	0.012
Smooth Plastic	0.011	0.009

The maximum full flow velocity shall be less than 15 feet per second (fps). The energy grade line (EGL) for the 5-year design flow shall be at or below finished grade at all manholes, inlets, or other junctions. The EGL and hydraulic grade line (HGL) for both the 5-year and 100-year events shall be calculated for all storm drain systems. Hydraulic losses will include friction, expansion, contraction, and junction losses at a minimum. The methods for estimating these losses are presented in the following sections. If the 100-year HGL is above any manhole or inlet cover, or if the manhole or inlet is located in a floodplain, manhole and inlet covers shall be bolted down.

802.7 Storm Drain Outlets

All storm drain outlets into open channels shall be constructed with a headwall and wingwalls or a flared end section. Riprap shall be provided at the outlet in the form of a blanket or low tailwater basin. Storm drain outlets shall meet the requirements of Section 1000 for culvert outlets.

803 HYDRAULICS OF STORM DRAINS

Presented in this section are the general aspects of hydraulic design and evaluation of storm drains that need to be considered. Hydraulic design calculations can be done manually with a spreadsheet or by using a computer model. Both methods are briefly discussed below. The user is assumed to possess a basic working knowledge of storm drain hydraulics and is encouraged to review technical literature available on the subject as needed.

803.1 Manual Hydraulic Calculations

Manual storm drain hydraulic calculations shall be performed in accordance with the HEC-22 (Brown et al., 2013). Procedures and coefficients presented in HEC-22 shall be used for system design unless they are specifically included in this MANUAL. HEC-22 includes discussion on open channel flow, where the water surface within the pipe remains open to the atmosphere, and pressure flow, where there is no exposed water surface within the pipe. It also includes a design example.

Two of the critical design elements of a storm drain system are the HGL and the EGL. The HGL is a line that represents the water surface elevation at any point along an open channel. In pressure flow situations, the HGL is the level to which water would rise in a vertical tube at any point along the pipe. The EGL is an imaginary line that represents the total energy at any point in the system. Total energy includes elevation head, velocity head, and pressure head and is the HGL plus the velocity head ($V^2/2g$). The total energy at any section equals the energy at any downstream section plus the losses that occur between the two points.

Losses are typically classified as either friction or form losses. Friction losses occur as water flows along the length of a pipe. Form losses occur at the exit from the system and at junctions such as manholes within the system. Because the county does not allow transitions or bends outside of manholes, form losses will be restricted to exit losses when flow leaves the system, and structure losses, such as through inlets or manholes and are referred to by HEC-22 as inlet and access hole losses. Although rare, losses due to hydraulic jumps in storm drains are discussed in Section 700, Open Channels.

803.2 Hydraulic Calculations Using a Computer Model

Computer models are often used to calculate the HGL and EGL of storm drain systems. The benefits of using a computer model include consistency, speed, and the ability to check the validity of the model with relative ease. This section provides specific guidance for UD-Sewer 2009; however, other programs such as StormCAD may be used if specifically approved by the county.

UD-Sewer is a computer model that assists in the design and flow analysis of storm drain systems. The program uses Manning's equation to analyze and size storm sewer systems. The program can also use

the Rational Method to calculate runoff, perform hydraulic and EGL calculations, and provide plots of the storm drain, ground line, HGL, and EGL. The USDCM (UDFCD, 2016) provides additional information, as does the UD-Sewer user's manual. The user's manual is embedded in the software, which can be obtained from the UDFCD website (<http://udfcd.org/software>) or via an internet search for "UDFCD UD-Sewer."

803.2.1 Rational Method

UD-Sewer uses the Rational Method to calculate runoff based on input parameters provided by the user. The user can override Rational Method calculations by manually entering known flows that have been calculated separately; however, values must be entered for Rational Method parameters or the program will give an error.

803.2.2 Bend and Lateral Loss Coefficients

UD-Sewer requires bend and lateral loss coefficients for each storm drain segment within a model. Bend and lateral losses both occur at a manhole or inlet junction. Bend losses are the result of the angle between the incoming storm drain and the exiting trunk line at a junction. Lateral losses are the result of turbulence or eddies that occur from lateral flows joining a trunk line. These coefficients are calculated by the program based on user inputs that define the geometry of the system.

To calculate the bend loss coefficient, the user must select the shape of the manhole invert and enter the angle between the incoming and downstream pipe segments. To calculate the lateral loss coefficient, the user must enter the angle between the incoming lateral and downstream trunk line. When entering the angle, the user must select main line or lateral line. Lateral loss is only applied to the main lines of a storm sewer system in UD-Sewer. For all lateral lines, the user should select lateral line and the program will default to zero. If more than one lateral enters a manhole, the user must exercise judgment to determine the appropriate loss coefficient.

804 HYDRAULICS OF STORM INLETS

Presented in this section are the general procedures for sizing and spacing of inlets in a storm drain system. Design calculations can be done manually, but this section will focus on the use of UD-Inlet to calculate street and inlet capacity. The USDCM provides additional details on the equations and methodologies that have been incorporated into the UD-Inlet spreadsheet.

804.1 Introduction

Inlets on a continuous grade are located so that ponding will not occur once the inlet is at capacity. Flow will instead bypass the inlet. Sump inlets are located at roadway sags or similar low points that will not allow water to bypass after the inlet reaches capacity. A sump condition can occur at a change in street grade from positive to negative or at an intersection due to the crown slope of a cross street.

804.2 Inlet Capacity

Inlet capacity may be calculated using the UD-Inlet spreadsheet developed by the UDFCD, with exceptions noted below. UD-Inlet is an Excel-based program that calculates both street and inlet

capacities based on several parameters entered by the user. In general, the procedure consists of defining the amount and depth of flow in the gutter and determining the theoretical flow interception by the inlet. The calculations within the spreadsheet program are based on physical research completed at Colorado State University. The most recent version of UD-Inlet can be obtained via an internet search for "UD-Inlet UDFCD" or from the UDFCD website (<http://udfcd.org/software>). Additional information specific to inlets on grade and in a sump condition is included in the following sections.

Information required by the spreadsheet includes design flow; height of curb; distance from curb face to street crown; gutter width; street cross and longitudinal slopes; gutter cross slope; Manning's n for the street; maximum allowable spread from gutter flow line; maximum allowable depth at gutter flow line; and allowable flow depth at the street crown. Additionally, if flow is allowed behind the curb, the allowable spread width behind the curb and side slope behind the curb, and Manning's n behind the curb must be entered. The spreadsheet can use the Rational Method to calculate a design flow or will accept a flow entered by the user. If the inlet receives bypass from an upstream inlet, the bypass flow can be entered or retrieved from another UD-Inlet spreadsheet. Default clogging factors included in the UD-Inlet spreadsheet shall be used to account for potential debris clogging, pavement overlaying, and varying design assumptions.

804.3 Continuous Grade Condition

The capacity of an inlet on grade is dependent on street slope, depth of flow in the gutter, height and length of curb opening, street cross slope, and the amount of depression at the inlet. Cost effective inlet design will allow for some bypass. The amount of carryover must be included in the drainage facility evaluation as well as in the design of the inlet. Boulder County allows Type R and Type 16 inlets in a continuous grade condition.

804.4 Sump Condition

The capacity of each sump inlet is dependent on depth of flow in the gutter, height and length of curb opening, street cross slope, and the amount of local depression at the inlet. Type R and Type 16 inlets are allowed for a sump inlet on curb and gutter system. A Type C inlet can be used in a ditch or as an area inlet.

At the time of publication of this MANUAL, UD-Inlet either overestimated or underestimated the capacity of inlets in sumps, leading to the installation of both oversized and undersized inlets throughout Colorado. A study done in 2007 entitled "Sump Inlet Hydraulics" found that current design procedures utilized by UD-Inlet were not consistent due to the application of inconsistent design parameters used to size a sump inlet under various conditions. Laboratory tests of several different inlet types were completed by the UDFCD in partnership with Colorado State University, and the data was used to modify design procedures for inlets in sumps. The USDCM provides modified design procedures for grate, curb opening, and combination inlets located in sumps that shall be used to design sump inlets in Boulder County.

804.5 Inlet Spacing

The optimum spacing of storm inlets is dependent upon several factors, including traffic requirements, contributing land use, street slope, allowable street capacity, and distance to the nearest outfall system.

The suggested sizing and spacing of the inlets is based on an ideal interception rate of 70 percent to 80 percent. This spacing has been found to be more efficient than a spacing using a 100 percent interception rate; although, the downstream-most inlet will still need to be designed to intercept 100 percent of the flow. Considerable improvements in overall system efficiency can be achieved if the inlets are located in the local sumps created by street intersections.

Inlet spacing is typically an iterative process, and the designer may have to move inlet locations multiple times before determining the appropriate spacing to meet design criteria and maintain efficiency. After initial inlet locations are determined, the designer should recalculate the peak flow to each inlet and check that the allowable street capacity has not been exceeded. If the actual flow is less than the allowable street capacity, inlets may be spaced further apart to prevent overdesign of a system. Locating inlets is a balance between meeting criteria and efficient design. It is not usually possible to have optimum inlet spacing throughout an entire storm drain system.

804.6 Inlet Grates

All grates used on storm inlets in Boulder County will be bicycle-safe grates in accordance with the *Guide for the Development of Bicycle Facilities* (AASHTO, 1999).

805 DESIGN OF STORM DRAIN SYSTEM

This section presents the general procedure used to design a storm drain system from preliminary through final design. Using the Rational Method for sizing the drain system is also discussed. A typical local drainage system consists of flow in the storm drain and allowable flow in the gutter. These flows are ultimately discharged to a larger drainage system or an open channel with capacity for a much larger event.

805.1 Preliminary Design

The preliminary design of the storm drain system begins after a preliminary development plan has been prepared that delineates the general development areas, major drainage paths, and drainage outfall locations. Allocation of space for drainage facilities and considerations shall be incorporated into the preliminary development plan. The drainage engineer must have input into the development plan to ensure proper drainage planning.

1. **Gather Basic Data.** The first step in any drainage project is the collection of basic data. Information typically required is as follows:
 - a. Topographic maps of the development and drainage basins that show existing and proposed roadways, existing and proposed land uses, major drainage features such as creeks and streams, development area, and property boundaries
 - b. Typical street cross sections
 - c. Preliminary grading information, such as contours, profiles, and control elevations
 - d. Soils information
 - e. Existing and proposed utilities

- f. Existing irrigation and raw water facilities and requirements for maintaining facilities
 - g. Rainfall information.
2. **Perform Hydrologic Analysis.** Perform the hydrologic evaluation of the basin(s) for both the minor and major storms, typically using the Rational Method. Divide each basin into smaller subbasins, and calculate the peak design flow for each hydrologic point of interest. The degree of basin subdivision will depend on the detail of information available and the experience of the licensed professional drainage engineer. Some general guidelines are included in Section 600.
 3. **Complete Preliminary Sizing.** Preliminary sizing should be completed for the minor storm. Beginning at the upper end of the basin, calculate the quantity of flow in the street until the allowable capacity of the street matches the design runoff. The storm drain system will start at this point, provided that no alternate method of removing runoff from the street exists. Removal of all the street flow by the storm drain system is not required, except at sump areas, and is typically not economical. The sum of the flow in the storm drain plus the flow in the street must be less than or equal to the allowable capacity of the street and storm drain.

For preliminary sizing purposes, the diameter, type of pipe, and slope is generally sufficient. Manning's n values should be those in Table 800-1. In some instances, a profile may be required to check utility conflicts or to assure compatibility with the major drainage system. The preliminary vertical alignment should not be steeper than the proposed street grade. The designer should also be aware of utility considerations, especially when crossing water and sanitary main and service lines.
 4. **Route the Major Storm.** After sizing the storm drain, route the major storm through the system and compare the flows to the allowable capacity. The combined total of the allowable street capacity during the major storm and the storm drain capacity during the major storm should equal or exceed the 100-year runoff. A plan and profile of the pipes, EGL, and HGL will be required. If the combined allowable capacity is less than the design flow, some or all of the following actions may be taken:
 - a. Increase storm drain size
 - b. Increase street grade within acceptable limits or revise street classification to allow additional capacity
 - c. Revise major drainage system such that the runoff is collected further upstream
 - d. Provide additional onsite detention within the development to decrease peak flow.
 5. **Evaluate the Preliminary Design.** In addition to a cost estimate for the design, the preliminary system can also be evaluated by developing alternatives and comparing the total benefits. The impact of the system outfall on downstream properties must be identified and mitigated if problems exist.

805.2 Final Design

Final design consists of final revisions to the system model and preparation of plans, profiles, and specifications for the storm drain system in sufficient detail for construction. Basic data, hydrologic analysis, and inlet sizing performed for the preliminary design should be reviewed and verified. Drainage subbasin boundaries should be confirmed or revised as necessary, and design peak flows should be

recalculated accordingly. The drain pipe and inlet sizes and locations are then finalized while taking into account final street and storm drain grades, locations of existing and proposed utilities, and the design of the major drainage system. The EGL and HGL should be revised accordingly including energy losses at manholes and any other structures. If special transitions are required to reduce losses, the structural design of the facilities must include energy loss considerations.

806 REFERENCES

American Association of State Highway and Transportation Officials, 1999. *Guide for the Development of Bicycle Facilities*, prepared by the AASHTO Task Force on Geometric Design, Washington, D.C.

Brown, S. A., J. D. Schall, J. L. Morris, C. L. Doherty, S. M. Stein, and J. C. Warner, 2013. *Urban Drainage Design Manual*, FHWA-NHI-10-009, Hydraulic Engineering Circular No. 22, Third Edition, prepared by Ayres Associates Inc., Fort Collins, CO, for the Federal Highway Administration, Washington DC, and the National Highway Institute, Arlington, VA.

Urban Drainage and Flood Control District, 2016. *Urban Storm Drainage Criteria Manual: Volume 1 Management, Hydrology, and Hydraulics*, prepared by the Urban Drainage and Flood Control District, Denver, CO.

Section 900 Roadways

Table of Contents

901	INTRODUCTION	900-1
902	FUNCTION OF STREETS IN THE DRAINAGE SYSTEM	900-1
903	DRAINAGE IMPACTS ON STREETS	900-1
904	STREET CLASSIFICATION	900-2
905	HYDRAULIC EVALUATION	900-2
	905.1 Streets With Curb and Gutter	900-2
	905.2 Roads With Roadside Ditches	900-5
906	ROADWAYS ADJACENT TO CHANNELS	900-7
907	REFERENCES	900-8

List of Tables

900-1	Allowable Flow Depth and Encroachment for County Roads	900-2
-------	--	-------

List of Figures

900-1	Gutter Section Composite Cross Slope	900-4
900-2	Reduction Factor for Gutter Flow	900-5
900-3	Example of a Roadside Ditch	900-5
900-4	Example of a Roadway Adjacent to a Channel	900-7

Section 900 Roadways

901 INTRODUCTION

The criteria presented in this section shall be used to determine allowable stormwater encroachment within public streets. The review of all planning submittals as outlined in Section 200 will be based on the criteria herein.

Street, road, and roadway are all general terms that denote a public way for purposes of vehicular travel, including the entire area within the right-of-way. The criteria herein will use these general terms interchangeably.

902 FUNCTION OF STREETS IN THE DRAINAGE SYSTEM

Curb and gutter sections and roadside ditches along urban and rural streets are part of both the Minor and Major Drainage Systems. When the drainage in the street exceeds the allowable limits, a storm drain system or an open channel is required to convey the excess flow. The primary function of streets is traffic movement, and the drainage function may only cause limited interference with the traffic function of streets.

The design criteria for collection and conveyance of runoff on public streets are based on a reasonable frequency and magnitude of traffic interference. Depending on the street classification, some traffic lanes are allowed to be fully inundated during the minor or major storm event. During less intense storms, runoff will inundate traffic lanes to a lesser degree. The primary function of streets as part of the Minor Drainage System is to convey nuisance flows to a storm drain system or open channel without interfering with traffic movement. As part of the Major Drainage System, the function of streets is to provide an emergency path for flood flows with minimal damage to the urban environment.

903 DRAINAGE IMPACTS ON STREETS

Storm runoff can affect traffic function of a street in the following ways:

1. Sheet flow across roadways
2. Concentrated flow in the gutter
3. Ponded water at low points
4. Concentrated flow across traffic lanes
5. Damage to the street section and required maintenance.

The criteria contained in this section of the MANUAL are intended to manage the impacts of stormwater on transportation infrastructure and to maintain a standard and consistent level of safety on county streets and roads during a given storm event.

904 STREET CLASSIFICATION

Each street in Boulder County has an assigned functional classification based on its role in connecting and providing access between various land uses. These functional classifications are listed in Boulder County's Multimodal Transportation Standards and assigned through the approval of the most recent Boulder County Road Map. The extent to which stormwater is allowed to encroach into the driving lanes of a roadway is based on that roadway's functional class. Limiting flow encroachment on a roadway is the primary criteria by which roadway safety is maintained during a storm event.

Although a majority of county roads will utilize a roadside ditch, some county streets will utilize a curb and gutter section. Using a curb and gutter or roadside ditch to convey flow does not affect the criteria for allowable encroachment because safety concerns remain the same for both types of roadways. The allowable lateral encroachment onto the roadway for each of the county's functional roadway classifications is presented in Table 900-1. These criteria may be listed by the width of roadway that must remain free of water or by the amount of ponding permissible at the crown during each storm event. In no case shall any roadway improvement, reconstruction, or expansion cause more flow encroachment on a parcel or structure outside the county right-of-way than currently exists. These criteria apply to roads with roadside ditches, curb and gutter sections, and culvert crossings. They do not apply to bridge crossings. Criteria for bridge crossings are included separately in Section 1000.

Table 900-1. Allowable Flow Depth and Encroachment for County Roads

Functional Classification	Minor Storm Encroachment	Major Storm Encroachment
Principal Arterial (PA)	10 feet clear each way	10 feet clear in center
Minor Arterial (MA)	Flow may spread to crown	Allowable depth at crown = 3 inches
Collector (C)	Flow may spread to crown	Allowable depth at crown = 3 inches
Residential Collector (RC)	Allowable depth at crown = 3 inches	Allowable depth at crown = 9 inches
Local (L)	Allowable depth at crown = 3 inches	Allowable depth at crown = 9 inches
Local Secondary (LS)	Allowable depth at crown = 3 inches	Allowable depth at crown = 9 inches
Townsite Road	Allowable depth at crown = 3 inches	Allowable depth at crown = 9 inches

905 HYDRAULIC EVALUATION

905.1 Streets With Curb and Gutter

The minor and major storm capacity of each street section may be calculated in one of two ways. The first is by using the UD-Inlet spreadsheet created by the UDFCD to calculate street and inlet capacities. The second is to calculate capacity manually using the Manning's equation shown as Equation 900.1 or the modified Manning's equation shown as Equation 900.2. Equations 900.1 and 900.2 assume a gutter cross slope equal to the roadway cross slope.

$$Q = \frac{0.56}{n} S_x^{5/3} S_L^{1/2} T^{8/3} \quad (900.1)$$

$$Q = \frac{0.56}{n S_x} S_L^{1/2} Y^{8/3} \quad (900.2)$$

where

Q = discharge (ft)

S_x = street cross slope (ft/ft)

Y = depth of water at face of curb (ft)

T = top width of flow spread (ft)

S_L = longitudinal grade of street (ft/ft)

n = Manning's roughness coefficient.

Roadway sections typically do not have gutter cross slopes equal to roadway cross slopes. A composite analysis must be completed for these sections, as presented by Equations 900.3 through 900.8.

$$Q = Q_w + Q_s \quad (900.3)$$

where

Q = total street section capacity (cfs)

Q_w = flow rate in the depressed section of the gutter (cfs)

Q_s = discharge in the section that is above the depressed section (cfs).

The theoretical flow rate, Q , is:

$$Q = \frac{Q_s}{1 - E_o} \quad (900.4)$$

where

$$E_o = \frac{1}{1 + \frac{S_w/S_x}{\left[1 + \frac{S_w/S_x}{(T/W) - 1}\right]^{8/3}} - 1} \quad (900.5)$$

where

$$S_w = S_x + \frac{a}{W} \quad (900.6)$$

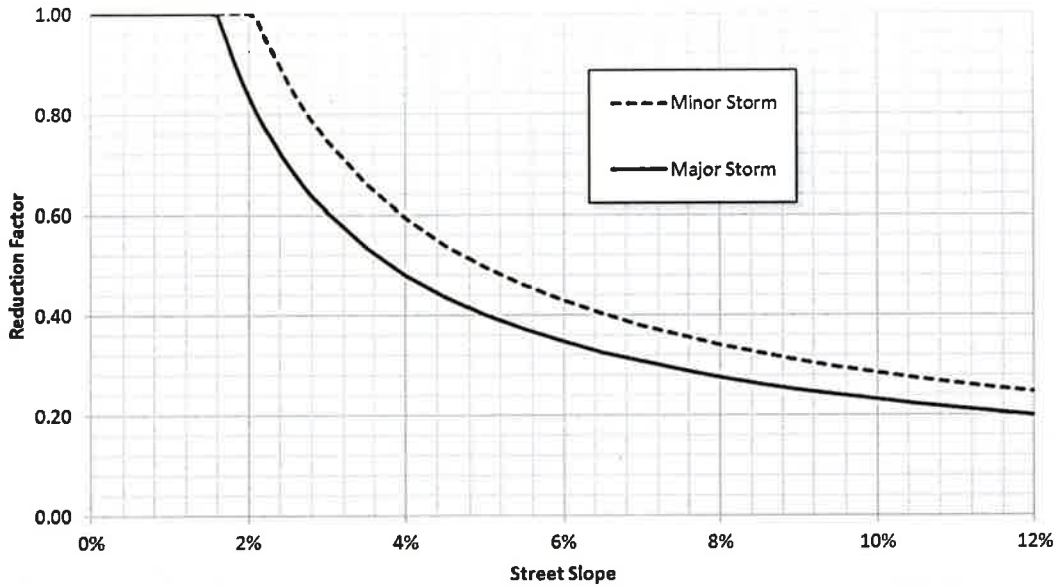

Figure 900-2. Reduction Factor for Gutter Flow (UDFCD, 2016).

905.2 Roads With Roadside Ditches

County roadways are often characterized by roadside ditches rather than a curb and gutter section. The capacity of the roadside ditch is limited by the ditch depth, maximum allowable flow velocity, and maximum allowable Froude number. A new or reconstructed roadside ditch must also not allow more flow to leave the county right-of-way during the major storm event than the currently existing configuration. Figure 900-3 shows a typical county roadside ditch.



Figure 900-3. Example of a Roadside Ditch (Boulder County, 2016).

Roadside ditch layouts will vary with each site's limitations and capacity requirements. Roadside ditch capacity shall be that which is required to limit encroachment as specified in Table 900-1. Safety is a primary concern in the roadside ditch design. Flatter side slopes and shallower depth are safer configurations than steeper side slopes and deeper depth. Side slopes recoverable by an errant vehicle are generally 4:1 or flatter. Slopes of 3:1 are considered a threshold for guardrail on heavily travelled roads. Where paths are adjacent to slopes steeper than 3:1, an optimum separation of 5 feet from the top of slope should be provided.

Right-of-way constraints and roadway slopes do not always allow for ideal ditch sections. A 3:1 maximum ditch side slope is preferred, but this may be steepened if right-of-way constraints require it. A depth of less than 24 inches is preferred, but this may be increased if necessary. Deeper ditches may be required if encroachment criteria cannot be met by using a flat-bottom ditch because of right-of-way constraints. Roadway slopes and ditch velocity restrictions may also require deeper ditches. Maximum allowable flow velocity and Froude number for roadside ditches are given in Section 700, Open Channels.

Stable cut and fill slopes shall be provided no steeper than 2:1 on the plains and 1.5:1 in mountainous areas as an absolute minimum standard. A geotechnical report may be required for slopes steeper than 2:1. Ditch slopes steeper than 3:1 must be protected by a turf reinforcing mat, crimped mulch, or riprap.

The layout of a roadside ditch can be especially challenging when the existing drainage pattern of an entire area is sheet flow toward the new roadway. This can occur in both the mountains and the plains. Once the roadway is constructed, sheet flow on the upstream side of the roadway will become concentrated in roadside ditches whose capacity may be quickly exceeded. There are two options for handling this flow. The first is to enlarge the ditches on the upstream side of the road to convey the design runoff until the ditch reaches a natural cross drainage. The second is to construct cross culverts at locations where there is not a natural cross drainage. For the second option, a ditch will then be required on the downstream side of the road to convey the runoff to the nearest natural drainage. It is not permissible to discharge concentrated runoff to a downstream property that is currently not receiving it without first acquiring easements and agreements from the property owner and providing a means of preventing erosion and routing the flow that is acceptable to the property owner.

Private driveway culverts located in roadside ditches must be sized to meet the criteria for the minor and major storm events in accordance with this MANUAL. The culverts must not create a headwater condition that violates the encroachment criteria in this section. These requirements apply to both new and replacement culverts, although existing culverts may be replaced in kind without a hydrologic and hydraulic analysis, provided the new culvert is at least 18 inches in diameter and that there is no evidence or report of erosion, roadway overtopping, or other damage to the area surrounding the culvert to be replaced. If evidence of any of these is found, the replacement culvert may be sized to match the larger of the nearest upstream and downstream culverts in the same ditch provided it is larger than the culvert being replaced and has not resulted in erosion, damage, or overtopping.

Section 1000 includes an example for sizing a private driveway culvert located in a roadside ditch. When culvert sizing results in an unreasonably large culvert that will not be readily accommodated by the existing roadside ditch, a Design Exception may be requested.

906 ROADWAYS ADJACENT TO CHANNELS

The design of roadways adjacent to open channels should consider the impacts both the roadway and the channel will have on each other. The goal of Boulder County is to construct new and replacement roadways above the 100-year floodplain to prevent damage to long stretches of roadway during large storm events. Depending on the characteristics of area surrounding the roadway, however, meeting this goal may not always be feasible or prudent.

When a replacement roadway is constructed in an area with a constricted floodplain, such as a canyon, raising the road grade will typically result in a more constricted channel width. This in turn may increase 100-year flow velocity and depth, possibly resulting in more damage to downstream facilities during a large event. If the 100-year floodplain is removed from the roadway, water may encroach onto private property on the other side of the channel where it otherwise would not. Causing any increase in water surface elevation on private property is not permitted without obtaining an easement from the property owner, one that the owner may refuse to grant. Figure 900-4 shows an example of a roadway adjacent to a channel.



Figure 900-4. Example of a Roadway Adjacent to a Channel (Boulder County, 2016).

If constructing a new or replacement roadway above the 100-year floodplain will result in additional floodwater encroachment onto private property or an increase in the 100-year floodplain, the approval process for a new or replacement roadway adjacent to a channel will require an alternatives analysis that includes an assessment of cost, benefit, and risk for each alternative. The analysis will evaluate the 5-year, 10-year, 25-year, and 100-year events at a minimum, and more return periods may be requested by the county. Alternatives will also consider protection of the roadway surface and subgrade, an analysis of public safety, and the potential for public notification or permanent signage.

907 REFERENCES

Boulder County, 2012. *Boulder County Multimodal Transportation Standards*, prepared by Boulder County, Boulder, Colorado.

Urban Drainage and Flood Control District, 2016. *Urban Storm Drainage Criteria Manual: Volume 1 Management, Hydrology, and Hydraulics*, prepared by the Urban Drainage and Flood Control District, Denver, CO.

Section 1000 Culverts and Bridges

Table of Contents

1001 INTRODUCTION	1000-1
1002 CULVERT DESIGN STANDARDS	1000-1
1002.1 CONSTRUCTION MATERIALS	1000-1
1002.2 MINIMUM CULVERT SIZE	1000-2
1002.3 ROADWAY OVERTOPPING.....	1000-2
1002.4 ALLOWABLE HEADWATER.....	1000-2
1002.5 VELOCITY AND OUTLET PROTECTION	1000-3
1002.6 HEADWALLS, WINGWALLS, AND END SECTIONS.....	1000-4
1002.7 STRUCTURAL DESIGN AND MINIMUM COVER.....	1000-4
1002.8 FISH PASSAGE.....	1000-4
1003 LOW WATER CROSSING DESIGN STANDARDS	1000-5
1003.1 EMBANKMENT AND ROADWAY SURFACING	1000-5
1003.2 SLOPE PAVING AND HEADWALL	1000-5
1003.3 ALLOWABLE BACKWATER	1000-6
1003.4 MAXIMUM CROSSING HEIGHT.....	1000-6
1003.5 STRUCTURAL DESIGN AND MINIMUM COVER.....	1000-6
1003.6 CULVERT SIZING	1000-6
1004 BRIDGE DESIGN STANDARDS	1000-6
1004.1 PUBLIC BRIDGE SIZING CRITERIA.....	1000-7
1004.2 HYDRAULIC ANALYSIS.....	1000-7
1004.3 INLET AND OUTLET CONFIGURATION.....	1000-7
1004.4 SCOUR ANALYSIS AND COUNTERMEASURES	1000-8
1004.5 DESIGN STANDARDS FOR PRIVATE DRIVEWAY BRIDGES.....	1000-8
1004.6 DESIGN STANDARDS FOR PEDESTRIAN BRIDGES.....	1000-11
1005 CULVERT HYDRAULICS.....	1000-11
1005.1 INLET CONTROL CONDITION	1000-12
1005.2 OUTLET CONTROL CONDITION	1000-13

1005.3	COMPUTER APPLICATIONS	1000-17
1006	DESIGN EXAMPLES	1000-17
1006.1	CROSSING CULVERT ANALYSIS EXAMPLE.....	1000-17
1006.2	LOW WATER CROSSING DESIGN EXAMPLE.....	1000-19
1006.3	PRIVATE DRIVEWAY CULVERT DESIGN EXAMPLE	1000-20
1007	REFERENCES	1000-22

List of Tables

1000-1	Types of Pipe, Materials, and Related Items Standards.....	1000-2
1000-2	Manning's n Values for Culverts.....	1000-3
1000-3	Required Culvert Outlet Protection	1000-3
1000-4	Bridge Scour Design Standards	1000-8
1000-5	Design Recurrence Intervals for Private Driveway Bridges.....	1000-9
1000-6	Freeboard Requirements for Private Driveway Bridges.....	1000-9
1000-7	Pedestrian Bridge Criteria.....	1000-11
1000-8	Inlet Control Nomograph Selection	1000-13
1000-9	Culvert Entrance Loss Coefficients, K_e , for Outlet Control Calculations (HDS-5)	1000-15
1000-10	Outlet Control Nomograph Selection	1000-16

List of Figures

1000-1	Example of a Concrete Box Culvert Adjacent to a Trail.....	1000-4
1000-2	Low Water Crossing Schematic	End of Section
1000-3	Example of a Bridge With an Aesthetic Component	1000-7
1000-4	Culvert Design Form	End of Section
1000-5	Inlet Control – Unsubmerged Inlet.....	1000-12
1000-6	Inlet Control – Submerged Inlet	1000-12
1000-7	Common Nomographs.....	End of Section
1000-8	Partially Full Conduit.....	1000-13
1000-9	Full Conduit.....	1000-14
1000-10	Culvert Design Form Example.....	End of Section
1000-11	Low Water Crossing Design Example	End of Section
1000-12	Private Driveway Culvert Example Ditch Geometry.....	1000-20

Section 1000 Culverts and Bridges

1001 INTRODUCTION

Culverts and bridges convey surface water through or beneath an embankment such as a highway, railroad, or canal. The size, alignment, and support structures of a culvert or bridge directly affect the capacity of the drainage system. An undersized culvert or bridge will force water out of the channel and cause flooding and damage. Culverts and bridges may significantly influence upstream and downstream flood risks, floodplain management, and public safety.

A Boulder County floodplain development permit is required for all work within a floodplain regulated by the county. FEMA regulations will apply to all work in a FEMA-regulated floodplain. Limited guidance on current FEMA and county floodplain regulations is included in Section 1400. These regulations are both nuanced and subject to change over time. MANUAL users are encouraged to consult the FEMA website and the county for guidance on regulations at the start of each project.

Because trails often follow drainageways such as creeks and rivers, a new bridge, bridge replacement, or large box culvert sometimes presents the opportunity to remove an at-grade trail crossing and replace it with a designated pathway under a bridge or through an additional box culvert section designed to house the trail. If this option is considered, design guidance can be found in the USDCM (UDFCD, 2016). Additionally, some flood control improvements may be eligible for UDFCD maintenance assistance. The UDFCD should be contacted to determine if a project qualifies.

The criteria presented in this section shall be used to evaluate and design culverts and bridges for public roadways and private driveways, whether they are located within the public right-of-way or not. The review of all submittals outlined in Section 200, Submittals will be based on the criteria herein. Stormwater crossings of CDOT roadways may have additional requirements.

1002 CULVERT DESIGN STANDARDS

Culverts shall be designed and constructed to the following standards. If any criteria for culverts are provided in the Boulder County Multimodal Transportation Standards, the criteria in this MANUAL will take precedence. All proposed culverts are subject to review and approval by the Boulder County Transportation Department. This includes culverts to be placed in both the public right-of-way and on private lands. Review must be conducted and approved by the Transportation Department regardless of whether a Building Permit, Floodplain Development Permit, or Access Permit is required.

1002.1 Construction Materials

All roadway cross culverts within Boulder County shall be reinforced concrete unless otherwise approved by the County Engineer and Road Supervisor. Culverts under private driveways may be reinforced concrete or corrugated steel. Aluminum and plastic culverts are not permitted. Construction materials used for irrigation and raw water lines within the county right-of-way must be approved by

the county before installation. The types of pipe, materials, and related items shall meet the most recent versions of the standards listed in Table 1000-1.

Table 1000-1. Types of Pipe, Materials, and Related Items Standards

Item	Standard
Reinforced Concrete Pipe—Round	ASTM C76 or AASHTO M 170
Reinforced Concrete Pipe—Elliptical	ASTM C507 or AASHTO M 207
Reinforced Concrete Pipe—Joints	ASTM C443 or AASHTO M 198
Reinforced Concrete Box Culvert—Joints	ASTM C1677
Reinforced Concrete Pipe—Arch	ASTM C506 or AASHTO M 206
Precast Concrete Box Culverts	ASTM C1433/C1577 or AASHTO M 259/M 273
Concrete for Cast-in-place culverts	CDOT 601
Corrugated Steel Pipe—Galvanized	AASHTO M 36
Structural Plate	ASTM A761 or ASHTO M 167

1002.2 Minimum Culvert Size

The minimum culvert size shall be an 18-inch-diameter round pipe or equivalent. Equivalents are a 22-inch by 12-inch arch or a 23-inch by 14-inch elliptical section.

1002.3 Roadway Overtopping

A major factor to be considered when designing a culvert under a roadway is the roadway’s functional classification and the associated allowable roadway encroachment or overtopping. Table 900-1 in Section 900, Roadways presents allowable roadway encroachment and overtopping criteria for culvert design for both the minor and major storm event for each of the county’s roadway classifications. Design standards and criteria for bridges is separate and is discussed in Section 1004.

Where roadway overtopping is anticipated to occur, the depth of overtopping can be assumed as the difference between the headwater elevation and the roadway crown elevation. This is a conservative estimate, as water will tend to spread out once it leaves the channel banks. Where overtopping is not permitted but some amount of encroachment is permitted, the culvert headwater elevation can be set at the elevation corresponding to the limits of encroachment.

For allowable overtopping, the roadway crown is assumed to act as a broad-crested weir. A weir coefficient of 2.8 shall be assumed along with a weir length not to exceed 100 feet, regardless of roadway geometry. The designer should first calculate weir flow using the allowable overtopping depth for the major storm as given in Table 900-1. The designer should then calculate flow through the culvert per Section 1005, with culvert headwater set at the allowable overtopping elevation. If the calculated weir flow plus the flow through the culvert exceeds the culvert’s 100-year design flow, the allowable overtopping condition has been met. Weir flow is discussed in the design example in Section 1006.2.

1002.4 Allowable Headwater

The maximum headwater for the 100-year design flow shall be 2.0 times the culvert diameter or culvert rise dimension for shapes other than round ($HW/D \leq 2.0$) for culverts with a rise dimension less

than or equal to 48 inches. For culverts with larger rise dimensions, the headwater to depth ratio for the 100-year design flow shall be less than 1.5. There is no maximum headwater value for the minor storm.

1002.5 Velocity and Outlet Protection

A minimum flow velocity within the culvert of 3 feet per second is required so that sediment will not accumulate in the culvert. The minimum flow velocity should be calculated using the Manning’s equation and assuming open channel flow and a normal depth equal to 0.25 times the vertical dimension of the culvert. Manning’s *n* values are presented in Table 1000-2.

Table 1000-2. Manning’s *n* Values for Culverts

Pipe Material	Manning’s <i>n</i>			
RCP	0.013			
Annular CMP (2½- × ½-inch corrugation) ^(a)	0.024			
Annular CMP (3 × 1-inch corrugations) ^(a)	0.027			
Helical CMP ^(a)	18 Inch	24 Inch	36 Inch	48 Inch
2½- × ½-inch corrugation	0.014	0.016	0.019	0.020
3- × 1-inch corrugations	N/A	N/A	0.021	0.023

(a) The *n* value for CMP shall be 0.027 unless pattern and corrugations are specified on the drawings.

The design must also include revetment to protect the outlet from erosion caused by the maximum velocity exiting a culvert. Table 1000-3 presents the required culvert outlet protection based on maximum culvert exit velocity. Maximum exit velocity shall be calculated using the major storm design flow and the methods described in Section 1005.

The most common type of culvert outlet protection is riprap, either as a riprap apron or as a low tailwater basin. Procedures for designing a riprap apron or low tailwater basin downstream of a culvert outlet, including for multiple conduit installations, can be found in the UDFCD’s USDCM. Both of these procedures are applicable for Froude numbers up to 2.5.

Table 1000-3. Required Culvert Outlet Protection

Culvert Exit Velocity (V)	Protection Required
V < 5.5 fps	None
5.5 fps < V < 16 fps	Riprap apron or low tailwater basin
> 16 fps	Energy dissipator structure

An economical culvert design that meets allowable headwater requirements should not normally result in a Froude number larger than 2.5 when design velocities are kept below 16 feet per second. The designer should generally strive to keep culvert slopes as flat as practicable to limit the amount of revetment that is required at the outlet. A riprap apron is typically used when the culvert is discharging

to a well-defined channel that can be expected to have a tailwater elevation equal to at least one-third of the height of the discharging conduit. A low tailwater basin is typically used when the receiving channel may have little or no tailwater or where the receiving channel is not well defined.

1002.6 Headwalls, Wingwalls, and End Sections

All culverts in the public right-of-way shall be designed with headwalls and wingwalls or flared end sections at the inlet and outlet, with the exception of private driveway culverts that are less than 36 inches in diameter, which may have projecting ends. Headwalls, wingwalls, and end sections shall be in accordance with the most recent edition of the CDOT M&S Standard Plans. Headwalls or end sections shall be located to provide a grade no steeper than 3H:1V between the back of the structure and the edge of the shoulder or back of walk. Outlet protection shall be provided at both the inlet and outlet of every culvert as required by Section 1002.5 until velocities fall below 5.5 feet per second. Figure 1000-1 is an example of a concrete box culvert in Boulder County.



Figure 1000-1. Example of a Concrete Box Culvert Adjacent to a Trail (Boulder County, 2016).

1002.7 Structural Design and Minimum Cover

Culvert installations shall be designed for the vehicular bridge loadings listed in the Boulder County Multimodal Standards, in accordance with the design procedures in the latest edition of the AASHTO Standard Specifications for Highway Bridges, or appropriate ASTM standard, and with the pipe manufacturer's recommendations. The minimum cover shall be 12 inches in all cases. Trench installations shall be in accordance with the most recent edition of the CDOT M&S Standard Plans.

1002.8 Fish Passage

Depending on the site location, a culvert may need to accommodate migrating fish. The U.S. Fish and Wildlife Services and the Colorado Parks and Wildlife should be consulted early in the planning process to determine requirements related to fish passage. Some locations may require a bridge to span the natural channel, but culvert modifications, including oversizing the culvert or placing it below grade and

filling the lower portion with native streambed material, can often be used to meet regulatory design criteria. All culvert projects should examine the potential to incorporate ecological components into the design.

1003 LOW WATER CROSSING DESIGN STANDARDS

A low water crossing is a privately constructed and maintained embankment structure that provides property ingress and egress through a floodplain. Low water crossings should be used only as a last resort and are only allowed for Local, Local Secondary, and Townsite Roads or private driveways at elevations less than 6,000 feet. Low water crossings are generally not feasible above 6,000 feet for several reasons. Typical stream cross sections in mountainous areas would require driveway slopes to be significantly above the maximum allowed by the Boulder County Multimodal Transportation Standards. In addition, if a low water crossing in a canyon were to block debris, the resulting backup in floodwater has less space available to spread out before causing damage to roadways and adjacent properties. The low water crossing is designed to allow access across the drainageway during a minor storm event. Access generally will not be possible during larger storm events.

If the low water crossing is located in a FEMA-regulated floodplain, it is subject to FEMA regulations, and design flow rates may be determined from the FEMA Flood Insurance Study (FIS), available by entering the crossing address into the FEMA Flood Map Service Center's interactive website at (<https://msc.fema.gov/portal>). Flow rates may also be available from studies published by Boulder County or from USGS gaging stations. For low water crossings on unstudied or ungauged streams, the design flow rates may be determined using the USGS program Streamstats that can be found at (<http://water.usgs.gov/osw/streamstats/colorado.html>).

Culverts in a low water crossing must meet the culvert design standards of Section 1002 for construction materials, minimum culvert size, velocity, and outlet protection. Low water crossings have unique design standards for allowable roadway overtopping, allowable headwater, and end treatments, as well as additional criteria for roadway surfacing, embankment materials, and backwater. The standards for design of low water crossings are below. Some are also included as part of Figure 1000-2, Low Water Crossing Schematic, located at the end of this section.

1003.1 Embankment and Roadway Surfacing

Embankment slopes shall not be steeper than 3H:1V, regardless of the surface treatment used. Embankment slopes within the public right-of-way shall be slope paved with concrete a minimum of 4 inches thick. Low water crossings outside the public right-of-way may be slope paved with 4 inches of concrete or protected with 18 inches of grouted, Type M riprap installed in accordance with UDFCD specifications. The roadbed for the approach to the crossing and over the crossing must be designed to withstand the forces of the 100-year overtopping event.

1003.2 Slope Paving and Headwall

The slope paving and headwall shall be as shown on Figure 1000-2, Low Water Crossing Schematic, located at the end of this section. Slope paving shall extend to the edge of the proposed roadbed. A vertical headwall and wingwalls will not be allowed for use in a low water crossing.

1003.3 Allowable Backwater

Backwater from the low water crossing shall not increase the 100-year water surface elevation by more than 1.0 feet on streams that are not regulated by FEMA.

1003.4 Maximum Crossing Height

The maximum crossing height for a low water crossing is the distance between the highest point on the road surface and the channel invert. The maximum crossing height shall be determined by comparing the channel capacity at the crossing location with and without the proposed crossing. The 100-year capacity above the proposed crossing, including the 1.0-foot allowable increase in the 100-year water surface elevation, shall be greater than the 100-year capacity without the crossing. The low water crossing design example in Section 1006.2 details the calculations required for this analysis. The existing water surface elevation for the 100-year event may be calculated using HEC-RAS or an iterative process using the Manning's equation. A site survey must be conducted to ensure accurate calculations.

1003.5 Structural Design and Minimum Cover

Minimum cover over low water crossing culverts shall be 12 inches for round corrugated metal pipe, 6 inches for round concrete pipe, and 18 inches for arch pipes or 12 inches for arch pipes if an HS 10-44 loading is applied. If the manufacturer recommends a larger minimum cover, that minimum shall be required.

1003.6 Culvert Sizing

The culvert sizing for a low water crossing shall be completed once the maximum crossing height is determined. The culvert size shall be determined using the minor storm event. Weir flow over the crossing is allowed up to a depth of 6 inches during the minor storm event. The culverts shall be sized for a capacity equal to the minor storm event minus the allowable weir overflow. The procedure used for low water crossing culvert sizing is presented in Section 1006.2.

1004 BRIDGE DESIGN STANDARDS

All bridges shall be designed in accordance with the latest edition of the Boulder County Multimodal Standards, although the criteria in this MANUAL will take precedence if there is a discrepancy. The majority of the criteria in this section apply to bridges on public roads. Section 1004.5 is dedicated specifically to private driveway bridges, and Section 1004.6 is dedicated specifically to pedestrian bridges. All bridges adjacent to roadways, regardless of category, must also adhere to the encroachment and overtopping requirements of Table 900-1. Design flow rates may be determined in the same manner as in Section 1003 for low water crossings. Figure 1000-3 shows an example of a bridge in Boulder County with an aesthetic component.

It is possible that a bridge designed to meet the criteria of this MANUAL may be on a roadway that becomes flooded during the storm event the bridge is designed to pass. New bridges shall be designed to the standards of this MANUAL regardless of adjacent roadway flooding because roadways that experience frequent flooding may be reconstructed at a higher elevation in the future to achieve an overall greater level of protection.

1004.1 Public Bridge Sizing Criteria

In addition to the criteria set forth in Section 1002, the low chord of any public bridge shall provide a minimum freeboard. If any criteria for freeboard are provided in the Boulder County Multimodal Transportation Standards, the criteria in this MANUAL will take precedence.

All bridges on Collector, Residential Collector, Local, and Local Secondary roadways, or with a 100-year flow that is less than 1,000 cfs, shall have a low chord elevation set at or above the energy grade line (EGL). All bridges on Minor Arterial and Principal Arterial roadways, or where the 100-year flow is higher than 1,000 cfs, shall have a low chord elevation set at least 1 foot above the EGL.



Figure 1000-3. Example of a Bridge With an Aesthetic Component (Boulder County, 2016).

1004.2 Hydraulic Analysis

The hydraulic analysis of a bridge opening is a complicated undertaking. Design calculations for all bridges must be prepared and certified by a licensed Colorado Professional Engineer. The procedures for design as outlined in the Federal Highway Administration (FHWA) publication *Hydraulic Design of Safe Bridges* shall be used for the hydraulic analysis of the proposed design. HEC-RAS may be used to complete the hydraulic analysis of bridge openings provided the guidance in the publication is followed. All bridges are assumed to remain in place during all storm events and shall not be assumed to break away or otherwise be removed from any modeling scenario.

1004.3 Inlet and Outlet Configuration

Where bridge abutments and foundations are located below the 100-year water surface elevation, concrete wingwalls shall be tied to the existing side slopes to prevent erosion behind the abutments and to provide slope stabilization from the top of the embankment to the toe of slope. Riprap protection on the inlet and outlet transition slopes shall be provided to prevent erosion caused by eddy currents.

1004.4 Scour Analysis and Countermeasures

Velocity limitations through the bridge opening are intended to limit potential scour. Regardless of the results of the scour analysis, a maximum 100-year average channel velocity of 16 feet per second shall be allowed through a bridge opening.

If any criteria for scour analysis are provided in the Boulder County Multimodal Transportation Standards, the criteria in this MANUAL will take precedence. Whenever a new or replacement bridge is designed, it is critical that scour depths at piers and abutments be estimated. The scour estimate must consider subsurface data and a hydraulic analysis of the proposed design.

The FHWA has published a set of Hydraulic Engineering Circulars to provide guidance for bridge scour and stream stability analysis. The set includes HEC-18, Evaluating Scour at Bridges, HEC-20, Stream Stability at Highway Structures, and HEC-23, Bridge Scour and Stream Instability Countermeasures: Experience, Selection, and Design Guidance. Latest editions of each shall be used in concert with each other to evaluate stream stability, potential scour, and appropriate scour countermeasures. HEC-RAS may be used to provide the raw data required for the HEC-18 equations. HEC-RAS may also be used to evaluate scour, but the user must be experienced in the nuances HEC-RAS presents in evaluating scour and the potential errors that can occur. Using HEC-RAS default values will cause inaccurate results.

The potential for local scour (pier and abutment) and general scour (contraction, stream degradation, and pressure) should be evaluated using HEC-18 to determine the extent of the various types of scour as applicable to each site. HEC-20 should be consulted to determine the general stability of the stream and whether lateral channel movement should be anticipated. If there is potential for scour during the scour design storm shown in Table 1000-4, countermeasures shall be designed in accordance with HEC-23. In all cases, the length of bridge piles shall be such that the design structural load may be safely supported entirely below the probable scour depth.

Table 1000-4. Bridge Scour Design Standards

Roadway Classification	Design Storm for Abutment, Pier Cap, and Retaining Wall Design	Design Storm for Foundation Design
Principal Arterial (PA)	500-year	500-year
Minor Arterial (MA)	500-year	500-year
Collector (C)	500-year	500-year
Residential Collector (RC)	100-year	500-year
Local (L)	100-year	500-year
Local Secondary (LS)	50-year	500-year
Townsite Road	50-year	500-year

1004.5 Design Standards for Private Driveway Bridges

According to the FHWA, scour at bridge foundations is the most common cause of bridge failure. Private driveway bridges are usually constrained by cost and other factors from meeting typical bridge scour design standards and are therefore, at a larger risk of failure from scour. To mitigate the scour threat, a risk- and resiliency-based approach has been adopted for private driveway bridges. This approach

factors in the importance of the bridge foundation stability in ensuring a safe and reliable waterway crossing and is referenced in HEC-18. The objective of these guidelines is to protect bridges from failure during relatively common flood events, such as the 5-, 10-, and 25-year events, while remaining within the constraints inherent in private driveway bridge design.

This MANUAL contains different design criteria for private bridges located in mountainous areas and those located in the plains areas of the county. When floodwaters overtop a private bridge or when a private bridge is knocked off its foundations during a storm event, the effects can be experienced by the entire community. Overtopping causes an increase in backwater upstream of the bridge, an increase in velocity through the bridge opening that could cause erosion downstream of the bridge, and the potential for debris to accumulate at the upstream face of the bridge, further increasing upstream backwater and downstream velocity. When a bridge is completely dislodged, it can cause an enormous channel blockage. These conditions are more critical in mountainous areas because of the reduced available floodplain width that exists in canyon roadways. A small blockage can result in a large increase in water surface elevation. By contrast, a reduction in capacity cause by blockages in the plains areas results in a smaller increase in water surface because the water has more room to spread out. Tables 1000-5 and 1000-6 provide criteria for the design private driveway bridges.

Table 1000-5. Design Recurrence Intervals for Private Driveway Bridges

Type of Crossing or Street Classification	Minimum Hydraulic Capacity Design Event ^(a)	Foundation and Scour Calculations Design Event ^(b)
Private Driveways below 6,000 feet of elevation	5-year flow	25-year
Private Driveways above 6,000 feet of elevation	10-year flow	50-year

- (a) Minimum hydraulic capacity shall be calculated using the freeboard requirements in Table 1000-6.
- (b) Should the required bridge foundation depth be unreasonable based on the predicted scour, appropriate scour countermeasures should be implemented to mitigate the predicted scour depth.

Table 1000-6. Freeboard Requirements for Private Driveway Bridges

Average Channel Flow Depth ^(a)	Minimum Required Freeboard (FB)
≥ 1.5 feet	Lesser of 1.5 feet and $(0.1Q^{0.3} + 0.008V^2)$
< 1.5 feet	0.5 feet

- (a) Average channel flow depth shall be for the design event specified in Table 1000-5 and shall be the average distance from the channel thalweg to the water surface taken at 50 feet upstream of the bridge, at the bridge, and at 50 feet downstream of the bridge.

The type of bridge foundation and foundation elevations should be determined by the bridge structural design engineer. During the design of the bridge foundations, the design engineer shall consider the

design loading, the findings of the geotechnical investigation, scour depth as calculated using the procedures in HEC-18, anticipated frost depth, pressure flow during the 100-year event, and any other factors the engineer considers appropriate in his or her professional judgement. If scour is anticipated, the engineer can either design scour countermeasures using the procedures in HEC-23 for the design storm listed in Table 1000-5 or locate the bridge foundations below the anticipated depth of scour by a distance that provides a sufficient factor of safety in his or her professional judgement. Scour countermeasures will be required if anticipated scour depth is in excess of 5 feet.

The superstructure and abutments of all private bridges shall be designed to withstand the buoyant and lateral forces generated by the 50-year event so that the superstructure will not become dislodged from the abutments during this event. The types of lateral forces to be considered include drag and impact forces from floating debris and ice and any other forces the engineer considers appropriate. The bridge will be designed to withstand twice the calculated buoyant and lateral forces of clear water to provide for the accumulation of debris.

Structural, scour, and foundation design calculations must be accompanied by a certification statement that is signed and sealed by a professional engineer licensed in the State of Colorado and submitted to the county for review. The certification statement shall read as follows.

I hereby affirm that the design calculations and plans for the private access bridge at [insert address] were prepared by me, or under my direct supervision, for the owners thereof, in accordance with the requirements of the International Building Code, the Boulder County Land Use Code, the Boulder County Multimodal Transportation Standards, the Boulder County Storm Drainage Criteria Manual, any approved variances and exceptions thereto, and my professional engineering judgment. I understand that Boulder County does not and will not assume liability for facilities, structures, or improvements designed by others.

Registered Professional Engineer

[Affix Seal]

State of Colorado No. _____

All assumptions made by the bridge design engineer shall be provided in the calculations. Furthermore, the design of all private bridges may be subject to review by a third party at the county's discretion. When located within a FEMA floodplain, all private driveway crossings are subject to requirements of the National Flood Insurance Program (NFIP) and local floodplain management regulations.

The county recognizes that in certain limited instances, it may be exceptionally difficult to conform to these standards. In these instances, the applicant will document in writing good and sufficient cause for a requested Design Exception on the most recent Boulder County Private Driveway Design Exception Request Form, which must then be signed and sealed by a professional engineer licensed in the State of Colorado.

Upon receipt of a written request for a Design Exception from a particular provision of this MANUAL, the County Engineer will issue a determination on whether the Design Exception should be granted or denied given the specific circumstances for which it was requested. The County Engineer will provide a copy of the determination to the applicant. Determinations made by the County Engineer in interpreting and enforcing the standards in this MANUAL involve the considered application of professional

engineering and transportation planning judgment and skill in the context of each particular situation and are not appealable

1004.6 Design Standards for Pedestrian Bridges

Several types of pedestrian bridges can be constructed in the county. Table 1000-7 below describes each type and the applicable criteria. The design of bridges crossing raw water ditches shall be in consultation with and approved by the ditch owner(s).

Table 1000-7. Pedestrian Bridge Criteria

Pedestrian Bridge Type	Description	Criteria
A – Small Trail Bridge	A private or public bridge crossing a stream, raw water ditch, or major drainage, not intended to carry motorized vehicles, and generally in low density and/or open areas	There are no capacity or minimum span length requirements. They may be tethered or designed to break away during a storm event less than the minor storm.
B – Private Access Pedestrian Bridge	A bridge crossing not intended to carry motorized vehicles, providing primary and/or sole access for users to private property.	These must comply with the private driveway bridge standards set forth in Section 1004.5. Breakaway or tethered designs are not permitted. When located within a FEMA floodplain, all private crossings are subject to the requirements of the National Flood Insurance Program (NFIP) and local floodplain management regulations.
C – Large Multiuse Bridges	A large bridge on a multiuse path or regional trail system, or used for maintenance access to or along a raw water ditch or major drainageway. These bridges are rated to carry small service vehicles including light duty pick-up trucks.	These must also comply with design standards for private bridges as set forth in Section 1004.5. Break away or tethered designs are not permitted. When located within a FEMA floodplain, all private crossings are subject to the requirements of the National Flood Insurance Program (NFIP) and local floodplain management regulations.

1005 CULVERT HYDRAULICS

Presented in this section are the general procedures that shall be used for hydraulic design and analysis of culverts. The user is assumed to possess a basic working knowledge of culvert hydraulics and is encouraged to review the technical literature on the subject that is included in FHWA HDS-5, Hydraulic Design of Highway Culverts. The two primary types of culvert flow are inlet control and outlet control. Under inlet control, the cross-sectional area of the barrel, inlet geometry, and headwater are the factors that affect capacity. Outlet control involves the additional consideration of tailwater and the slope,

roughness, and length of the culvert barrel. The Culvert Design Form, shown in Figure 1000-4, is a template for culvert hydraulic analysis that can be used with the information and equations below. It can be found at the end of this section.

1005.1 Inlet Control Condition

Under inlet control conditions, the slope of the culvert is steep enough that the culvert does not flow full. The control section of a culvert operating under inlet control is located just inside the entrance. Inlets may be either unsubmerged or submerged. In an unsubmerged condition, the headwater is not sufficient to submerge the top of the culvert and the culvert slope is supercritical, as shown in Figure 1000-5. In this situation, the culvert inlet acts like a weir.

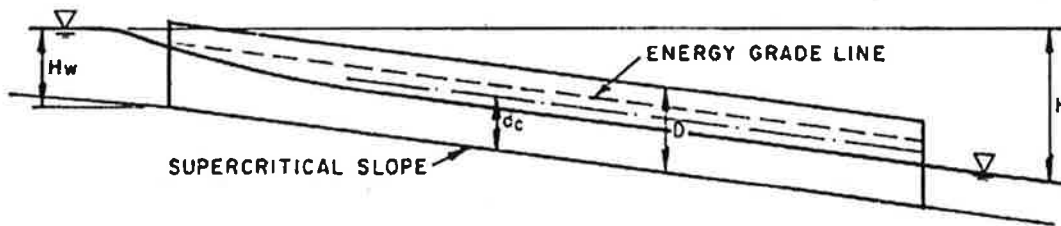

Figure 1000-5. Inlet Control – Unsubmerged Inlet (UDFCD, 2016).

In a submerged condition, the headwater submerges the top of the culvert but the pipe does not flow full, as shown in Figure 1000-6. In this situation, the culvert inlet acts like an orifice.

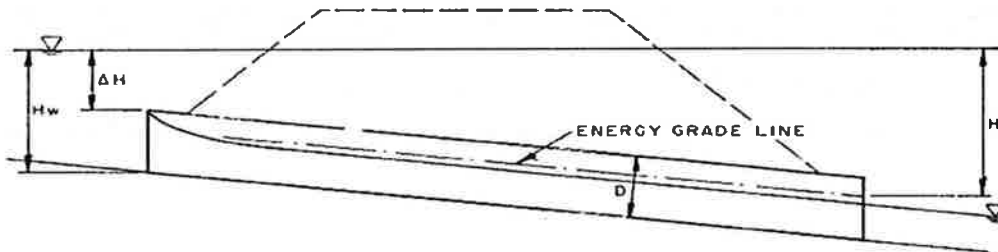

Figure 1000-6. Inlet Control – Submerged Inlet (UDFCD, 2016).

In the submerged inlet condition, the equation governing the culvert capacity is the orifice flow equation. However, because of the uncertainty in estimating the orifice coefficient for a submerged culvert inlet, it is recommended that the inlet control nomographs published in HDS-5 be used to determine headwater for submerged inlets operating under inlet control. Some of the more commonly used nomographs are included at the end of this section, cumulatively designated as Figure 1000-7, Common Nomographs. The remainder can be found in the second edition of HDS-5, publication number FHWA-NHI-01-020. Table 1000-8 provides the appropriate chart to use for various types of culverts and end treatments.

Table 1000-8. Inlet Control Nomograph Selection

Material	Cross Section	End Treatment	Chart
Concrete	Circular	None (Projecting), Headwall	1B
Concrete	Circular	Flared end section ^(a)	1B
Concrete	Horizontal Elliptical (Oval)	Headwall or Projecting (use scale 1 for end section)	29B
Corrugated Metal	Circular	None (Projecting), Headwall, Mitered	2B
Corrugated Metal	Circular	Flared end section ^(a)	2B
Concrete	Rectangular	Wingwalls, angle and headwall bevel varies	8B-13B

(a) End sections conforming to fill slope are the sections commonly available from manufacturers. From limited hydraulic tests they are equivalent in operation to a headwall in both inlet and outlet control (HDS-5, 2012).

1005.2 Outlet Control Condition

Outlet control occurs when the culvert barrel is not capable of conveying as much flow as the inlet opening will accept. Either subcritical or pressure flow exists in the culvert barrel under these conditions. Outlet control will govern if the headwater is deep enough, the culvert slope is sufficiently flat, or the culvert is sufficiently long.

Outlet control generally exists under two conditions. The first, and less common, occurs when headwater is not high enough to submerge the top of the culvert and the culvert slope is subcritical, as shown in Figure 1000-8.

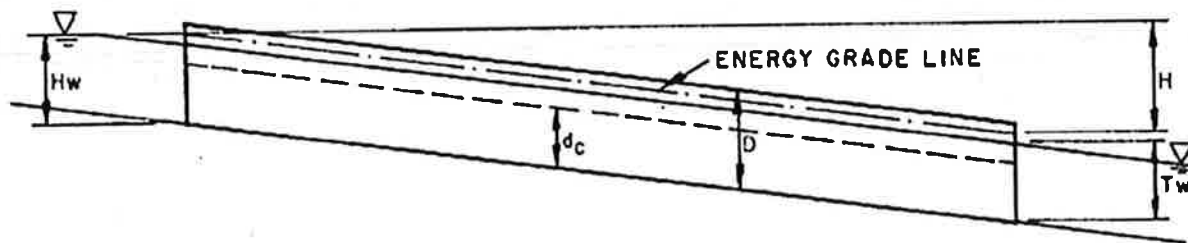

Figure 1000-8. Partially Full Conduit (UDFCD, 2016).

The more common outlet control condition exists when the culvert is flowing full, as illustrated in Figure 1000-9. A culvert with a submerged inlet and an unsubmerged outlet may also operate under outlet control, especially if it has a long barrel length or a flat enough slope. Culverts under outlet control may flow full or partly full, depending on various combinations of hydraulic factors.

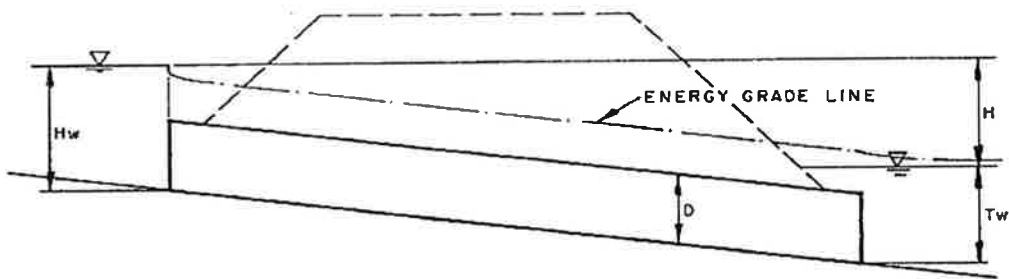

Figure 1000-9. Full Conduit (UDFCD, 2016).

Culvert capacity under outlet control is calculated using Bernoulli's equation for the conservation of energy. An energy balance is determined between the headwater at the culvert inlet and at the culvert outlet and includes inlet losses, friction losses, and velocity head. The general equation is expressed as:

$$H = h_e + h_f + h_v \quad (1000.1)$$

where

H = total energy head (ft)

h_e = entrance head loss (ft), $K_e V^2 / 2g$

h_f = friction losses (ft)

h_v = velocity head (ft), $V^2 / 2g$

K_e = entrance loss coefficient per Table 1000-8.

Friction loss is the energy required to overcome the culvert barrel roughness and is calculated by the following equation.

$$h_f = \left(29n^2 L / R^{1.33} \right) (V^2 / 2g) \quad (1000.2)$$

where

n = Manning's coefficient per Table 1000-3

L = Length of culvert (ft)

R = Hydraulic radius (ft)

V = Velocity of flow (fps)

g = Acceleration due to gravity, $32.2 \text{ ft} / \text{s}^2$.

Table 1000-9. Culvert Entrance Loss Coefficients, K_e , for Outlet Control Calculations (HDS-5)

Structure and Entrance Type	K_e	Structure and Entrance Type	K_e
RCP		RCB	
Headwall, socket end of pipe	0.2	Wingwalls at 30° to 75° to barrel	
Headwall, square edge	0.5	Square edge at crown	0.4
Projecting from fill, socket end	0.2	Rounded or beveled top edge	0.2
Projecting from fill, square cut end	0.5	Wingwalls at 10° to 25° to barrel	
Mitered to conform to fill slope	0.7	Square edge at crown	0.5
Side- or slope-tapered inlet	0.2	Wingwalls parallel (side extensions)	
Beveled edges, 33.7° or 45° bevels	0.2	Square edge at crown	0.7
Rounded (radius = D/12)	0.2	Side- or slope-tapered inlet	0.2
End section that conforms to fill slope ^(a)	0.5	No wingwalls	
CMP ^(b)		Square edge on 3 sides	0.5
Projecting from fill	0.9	Rounded or beveled on 3 sides	0.2

(a) End sections that conform to fill slope are the sections commonly available from manufacturers. From limited hydraulic tests, they are equivalent in operation to a headwall in both inlet and outlet control. Some end sections, which incorporate a closed taper in their design, have a superior hydraulic performance. These latter sections can be designed by using the information given for the beveled inlet.

(b) Conditions not listed specifically for CMP have the same coefficient as RCP.

Combining the equations yields the following equation, which can be used to calculate culvert capacity directly only when the tailwater is at or above the crown of the culvert outlet.

$$H = (K_e + 1 + 29n^2L / R^{1.33})(V^2 / 2g) \tag{1000.3}$$

When the tailwater is below the culvert outlet crown, the tailwater depth used for calculations shall be the larger of the tailwater anticipated in the downstream channel at the culvert outlet and the average of the critical depth in the culvert and the culvert diameter, $(D+d_c)/2$. The FHWA has determined the average of the critical depth and the culvert diameter to be an adequate approximation for tailwater depth for culverts that flow partially full. Critical depth calculation is a direct process for a box culvert but an iterative one for a circular pipe that is easily accomplished with a spreadsheet. Critical depth occurs when the Froude number is equal to 1.0. The flow area and top width will be those that occur at critical depth in the pipe. Many online tutorials are available.

$$Fr = \frac{v}{\sqrt{gD_h}} \tag{1000.4}$$

where

Fr = Froude number (dimensionless)

v = velocity (ft/s)

g = gravitational acceleration (32.2 ft/s²)

D_h = hydraulic depth, $D_h = A/T$ (ft)

A = flow area (ft²)

T = top width of flow area (ft).

In addition to equation 1000.3, outlet control nomographs published by the FHWA in HDS-5 can also be used to calculate the required headwater under outlet control conditions where the outlet is submerged. Some of the more commonly used nomographs are included at the end of this section, included within Figure 1000-7. The remainder can be found in the second edition of HDS-5, publication number FHWA-NHI-01-020. Table 1000-10 provides the appropriate chart to use for various types of culverts. End treatments do not affect outlet control.

Table 1000-10. Outlet Control Nomograph Selection

Material	Cross Section	Chart
Concrete	Circular	5B
Corrugated Metal	Circular	6B
Concrete	Rectangular	15B
Concrete	Horizontal Elliptical (Oval)	33B

When using the outlet nomographs for corrugated steel pipe, the data must be adjusted to account for the variation in the n value between the nomographs and the culvert being evaluated. The adjustment is made by calculating an equivalent length according to the following equation:

$$L' = L(n'/n)^2 \tag{1000.5}$$

where

L' = Equivalent length

L = Actual length

n = Manning's n value, shown on the HDS-5 nomographs

n' = Actual n value of a culvert from Table 1000-2.

Culvert capacity shall be computed using the Culvert Design Form in Figure 1000-4 at the end of this section. Three example calculations for culvert sizing are provided in Sections 1006.1 through 1006.3. The first is for a roadway crossing culvert, the second is for a low water crossing, and the third is for private driveway culvert in a roadside ditch. The FHWA HDS-5, Hydraulic Design of Highway Culverts,

offers extensive guidance on the design of culverts that are under roadways and that may be used in conjunction with the requirements of this MANUAL.

1005.3 Computer Applications

Although the procedures and nomographs for analyzing culvert hydraulics are still used, engineers increasingly design culverts by using computer applications. Among the applications approved for use by Boulder County is the FHWA's HY-8 Culvert Analysis Program and the UDFCD's UD-Culvert spreadsheet, both of which may be used to calculate roadway overtopping, inlet and exit velocity, and hydraulic grade line.

1006 DESIGN EXAMPLES

Three design examples are included in this section. The first example details the analysis of an existing roadway crossing culvert by using the Culvert Design Form. The second is for design of a private driveway culvert in a roadside ditch. The third is for the design of a low water crossing.

1006.1 Crossing Culvert Analysis Example

The procedure to evaluate culverts is based on the procedures presented in HDS-5. The methodology consists of evaluating the culvert headwater requirements for both inlet and outlet control. The type of flow control that results in a larger required headwater is the governing flow condition.

An example calculation for rating an existing culvert is presented in Figure 1000-10, Culvert Design Form Example, located at the end of this section. The culvert is a 48-inch CMP with $2\frac{2}{3} \times \frac{1}{2}$ -inch annular corrugations. The length is 150 feet. The upstream invert elevation is 5540.0, and the downstream invert elevation is 5535.5. The slope is 0.030. The low point of the embankment over the culvert has an elevation of 5551.9. The n value is 0.024 (from Table 1000-2). The culvert has flared end sections. All depths in Figure 1000-10 are in feet unless noted otherwise.

The tailwater rating values are provided for this example and shown in Column 5 of Figure 1000-10. If the tailwater condition is unknown, it must be computed using the normal depth (subcritical or critical only) of a trapezoidal channel approximating the existing drainageway. A HEC-RAS model of the site could also be used to determine the tailwater rating curve.

The entrance loss coefficient, K_e , can be determined from Table 1000-9 as 0.5 for an end section that conforms to fill slope, which is the category used to represent a common flared end section. The full flow and the velocity are calculated from these values for comparison. The rating then proceeds in the following sequence:

- **Step 1:** The culvert design process begins with selecting a discharge range or a headwater depths range and then using an inlet control nomograph to determine the corresponding values. This example begins with a range of headwater depths that are entered in Column 3. Headwater to pipe diameter ratios (H_w/D) are calculated and entered in Column 2. If the culvert is not circular, the culvert height is used for the calculation.

- **Step 2:** For each H_w/D ratio, inlet capacity is read from the appropriate inlet control nomograph (Chart 2B for this example) and entered into Column 1. Flared end sections are hydraulically equivalent to headwalls according to HDS-5. Scale (1) should be used on Chart 2B to determine discharges, which then completes the inlet control rating.
- **Step 3:** For outlet control, the Q values that have been entered in Column 1 are used to determine the head values (H) in Column 4 from the appropriate outlet control nomograph (Chart 6B for the example).
- **Step 4:** The tailwater depths (T_w) are then entered into Column 5 for each Q value in Column 1. The depths have been provided in this example, but must be calculated if they are not available. If the tailwater depth is less than the diameter of the culvert, Columns 6 and 7 must be calculated per Step 5, and the larger of the tailwater depth and the value of Column 7 shall be used as h_o . If the tailwater depth is greater than the diameter of the culvert, the tailwater values in Column 5 are entered into Column 8 as the values for h_o , and Step 6 should begin (Step 5 being skipped).
- **Step 5:** Approximate tailwater depths are calculated if tailwater depths from Step 4 are less than the diameter of the culvert. The critical depth, d_c , for each Q value in Column 1 is calculated and entered into Column 6. The average of the critical depth and the culvert diameter is calculated and entered into Column 7 as the approximate h_o value.
- **Step 6:** The headwater values (HW) are calculated according to Equation 1000.6:

$$H_w = H + h_o - LS_o \quad (1000.6)$$

where H is from Column 4 and h_o is either the value from Column 8 where $T_w \geq D$ or the larger value of Column 5 and Column 7 where $T_w < D$. L is the length of the culvert barrel and S_o is its slope.

- **Step 7:** The final step is to compare the inlet and outlet control headwater requirements (Columns 3 and 9) and record the higher of the two values in Column 10. The type of flow control is recorded in Column 11. The headwater elevation is calculated by adding the controlling headwater (Column 10) to the upstream invert elevation. A culvert's rating curve can then be plotted from the values in Columns 12 and 1.

Outlet velocity for designing downstream protection can be computed using $V = Q/A$. For full flow conditions, the culvert area is the full cross sectional area of the culvert. For partially full conditions, the culvert area is the area calculated at a depth of h_o . Channel protection shall be as described in Section 1002.5. Velocity values are not shown in Figure 1000-10 but should be calculated for the 100-year event. To size a culvert crossing, the same form can be used, with some variation in the basic data. First, a design Q is selected and the maximum allowable headwater is determined, subject to the conditions of Section 1002.4. An inlet type is selected and the invert elevations and culvert slope are estimated based on site constraints. A culvert type and size is then selected and rated for both inlet and outlet control. If the controlling headwater exceeds the maximum allowable headwater, design data should be modified and the procedure repeated until the desired results are achieved.

1006.2 Low Water Crossing Design Example

A low water crossing is planned in an ungauged stream with steep vegetated banks and an invert composed mostly of gravel and cobble. StreamStats indicates the major storm discharge is 1430 cfs and the minor storm discharge is 200 cfs. The existing channel has an average slope of 1.6 percent and a typical cross section is shown in Figure 1000-11, Low Water Crossing Design Example, at the end of this section. A Manning's n value of 0.040 is assigned to the channel in accordance with Section 700. Design of a low water crossing is an iterative approach described in the steps below. AutoCAD, spreadsheet software, and HEC-RAS can all be used to assist with the analysis.

- **Step 1:** Calculate the existing 100-year water surface elevation. Determine the flow area, wetted perimeter, and hydraulic radius of the typical section at several different water surface elevations. Use Manning's equation to determine discharge at each of those water surface elevations. Adjust the water surface elevation until the calculated discharge is equal to the 100-year flow rate. In this example, a water surface elevation of 5406.0 resulted in a discharge of 1,431 cfs, which is acceptably close to the 100-year flow rate of 1,430 cfs. This water surface is shown in Figure 1000-11 at the end of this section.
- **Step 2:** Calculate the proposed 100-year water surface elevation. A low water crossing may cause a maximum increase of 1.0 feet in the 100-year water surface elevation. The proposed 100-year water surface elevation is 5407.0 feet, which is also shown in Figure 1000-11 at the end of this section.
- **Step 3:** Determine the proposed road grade elevation. Using Manning's equation, calculate the discharge above several potential road grade elevations using the existing conditions n value and the proposed 100-year water surface elevation of 5407.0. Do not account for flow in any potential culverts. The entire 100-year flow should pass over the low water crossing. Select the highest road grade elevation that will convey a flow equal to or slightly greater than the 100-year discharge at a water surface of 5407. In this example, a discharge of 1,462 cfs was calculated at a corresponding road grade elevation of 5404.1, shown in Figure 1000-11 at the end of this section. This flow rate is considered acceptably close to the 100-year flow rate of 1,430 cfs.
- **Step 4:** Calculate the discharge over the road grade during the minor storm. The maximum allowable overtopping depth (H) is 0.5 feet during the 5-year event. Use the weir equation, equation 1000.7, to determine the 5-year discharge over the low water crossing, Q_o , using a weir coefficient (C) of 2.8. The length of the weir (L) can be determined from the typical channel cross section and the selected road grade elevation, up to a maximum of 100 feet. In this example, the weir length is 38 feet.

$$Q_o = CLH^{3/2} \quad (1000.7)$$

$$Q_o = (2.8)(38)(0.5)^{3/2} = 37.6 \text{ cfs} \quad (1000.8)$$

- **Step 5:** Determine the minimum required culvert capacity, Q_p . This is the difference between the channel 5-year design flow and the allowable discharge over the low water crossing.

$$Q_p = Q_s - Q_o = 200 - 37.6 = 162 \text{ cfs} \quad (1000.9)$$

- **Step 6:** Select the culvert size. The proposed road grade elevation must accommodate the selected culvert size with the minimum allowable cover over the top of the pipe. Assume a 53-inch by 34-inch HERCP, which has a wall thickness of 5 inches. The proposed road grade is 49 inches above the channel invert ($5404.1 - 5400.0 = 4.1$ feet = 49 inches). The distance from the pipe invert to the top of the pipe is 39 inches ($34 + 5 = 39$ inches). This results in 10 inches of cover between the top of the pipe and the road grade. This distance is greater than the allowable minimum of 6 inches, and the 53-inch by 34-inch Horizontal Elliptical Reinforced Concrete Pipe (HERCP) is an acceptable alternative.
- **Step 7:** Calculate the number of culverts required. Assume inlet control and use the nomograph in Chart 29B to calculate capacity of the 53-inch by 34-inch HERCP. Allowable headwater is equal to the proposed crossing height plus 6 inches of allowable overtopping, or 55 inches ($49 + 6 = 55$ inches). The ratio of headwater to interior pipe height, HW/D , is 1.62 ($55 \text{ inches} / 34 \text{ inches} = 1.62$). Because there is no scale for an entrance that is mitered to conform to the slope, use Scale 1 to the right of the nomograph. The nomograph indicates the capacity of a single culvert to be 84 cfs. The number of culverts needed is calculated by dividing the total required culvert capacity by the individual culvert capacity, or $162 \text{ cfs} / 84 \text{ cfs} = 1.9$. Rounding up, two culverts are required.

The low water crossing will use two 53-inch by 34-inch HERCP culverts with a road grade elevation of 5404.1. Figure 1000-11 shows the final design data.

1006.3 Private Driveway Culvert Design Example

A driveway is planned to provide access to a new residence from a collector roadway with an existing roadside ditch. The collector has a transverse slope of 2 percent. The roadside ditch is trapezoidal with 1:1 side slopes, a 2-foot bottom width, and a 3.5-foot depth as shown in Figure 1000-12.

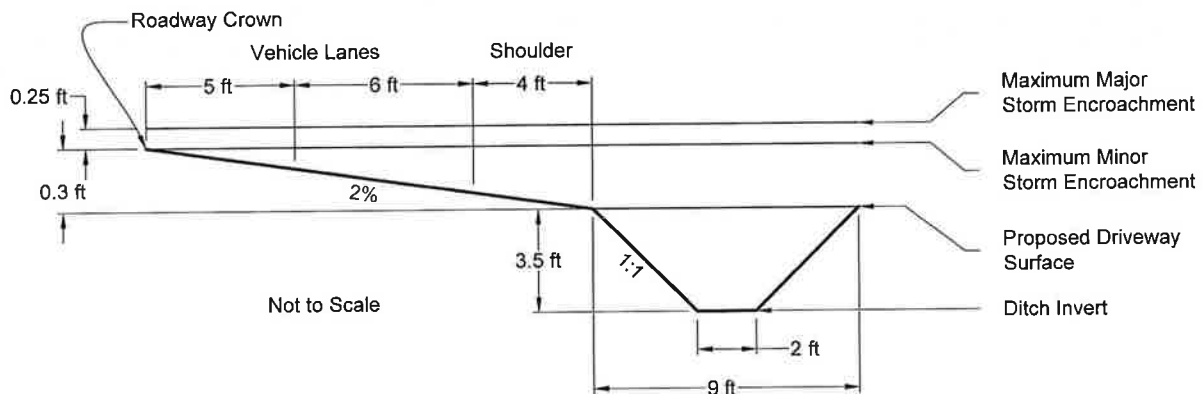

Figure 1000-12. Private Driveway Culvert Example Ditch Geometry.

The driveway is assumed to have no slope over the ditch for calculation purposes. The calculated discharge for the major design storm is 28 cfs. The minor design storm discharge is 12 cfs. Floodwater encroachment onto the road must not exceed the limitations set forth in this MANUAL. Inlet control is assumed for this example; however, actual projects should use Figure 1000-4, Culvert Design Form, at the end of this section to determine if culverts are under inlet or outlet control.

- **Step 1:** During the major storm, water on a collector may be 3 inches deep at the crown of the road as shown in Table 900-1. The depth of the water from the crown of the road to the ditch invert is 4.05 feet. This value is assumed as the headwater depth.
- **Step 2:** Calculate the discharge through an 18-inch CMP ($D = 1.5$ feet) with flared end sections and a headwater depth of 4.05 feet using Chart 2B.

$$\frac{Hw}{D} = \frac{4.05 \text{ ft}}{1.5 \text{ ft}} = 2.7 \quad (1000.10)$$

HDS-5 states that flared end sections are hydraulically equivalent to headwalls. A HW/D ratio of 2.7 on Scale 1 of Chart 2B gives a discharge of 15.5 cfs for an 18-inch CMP.

- **Step 3:** Calculate weir flow over the road and driveway during the major storm. Flow over the road and ditch are calculated independently. Because the road grade is sloped across the cross section, the average depth of flow over the road is used. Flow outside the top of the ditch side slope is assumed to be negligible for this example, but it may be considered if the designer feels it is appropriate. Assume a weir coefficient of 2.8.

$$\begin{aligned} Q_{weir} &= Q_{road} + Q_{driveway} \\ Q_{weir} &= CLH^{3/2} + CLH^{3/2} \\ Q_{weir} &= (2.8)(15)\left(\frac{0.55+0.25}{2}\right)^{3/2} + (2.8)(9)(0.55)^{3/2} \\ Q_{weir} &= 16.9 \text{ cfs.} \end{aligned} \quad (1000.11)$$

Total flow over the road and driveway is 16.9 cfs.

- **Step 4:** The combined flow through the 18-inch CMP and over the road/driveway is 32.4 cfs, which is more than the major design storm flow. Encroachment onto the collector will not exceed allowable and the chosen culvert is acceptable. If the combined flow would have been less than the major storm flow, a larger culvert would be required, and Steps 2–3 would be repeated using a 24-inch CMP.
- **Step 5:** Verify that the minor storm meets criteria. During the minor storm, flow may spread to the crown of a collector. Assuming encroachment extends to the roadway crown yields a headwater depth of 3.8 feet.

$$\frac{Hw}{D} = \frac{3.8 \text{ ft}}{1.5 \text{ ft}} = 2.53 \quad (1000.12)$$

Chart 2B indicates a capacity of 15 cfs, which is greater than the minor storm flow. Encroachment will meet criteria.

- **Step 6:** Verify that the culvert has a minimum 12 inches of cover. The driveway surface is 3.5 feet or 42 inches above the ditch invert.

$$42 \text{ in} - 18 \text{ in} = 24 \text{ in} \quad (1000.13)$$

The 18-inch CMP has 24 inches of cover, which is greater than the 12-inch minimum. An 18-inch CMP meets all criteria for this location.

1007 REFERENCES

Urban Drainage and Flood Control District, 2016. *Urban Storm Drainage Criteria Manual: Volume 2 Structures, Storage, and Recreation*, prepared by the Urban Drainage and Flood Control District, Denver, CO.

Schall, J. D., P. L. Thompson, S. M. Zegers, R. T. Kilgore, and J. L. Morris, 2012. Hydraulic Design Series Number 5 (HDS-5) *Hydraulic Design of Highway Culverts*, Third Edition, HIF-12-026, prepared by Ayres Associates, Fort Collins, CO, for the U.S. Federal Highway of Administration, Washington, DC.

Figure 1000-7 Common Nomographs

CHART 1B

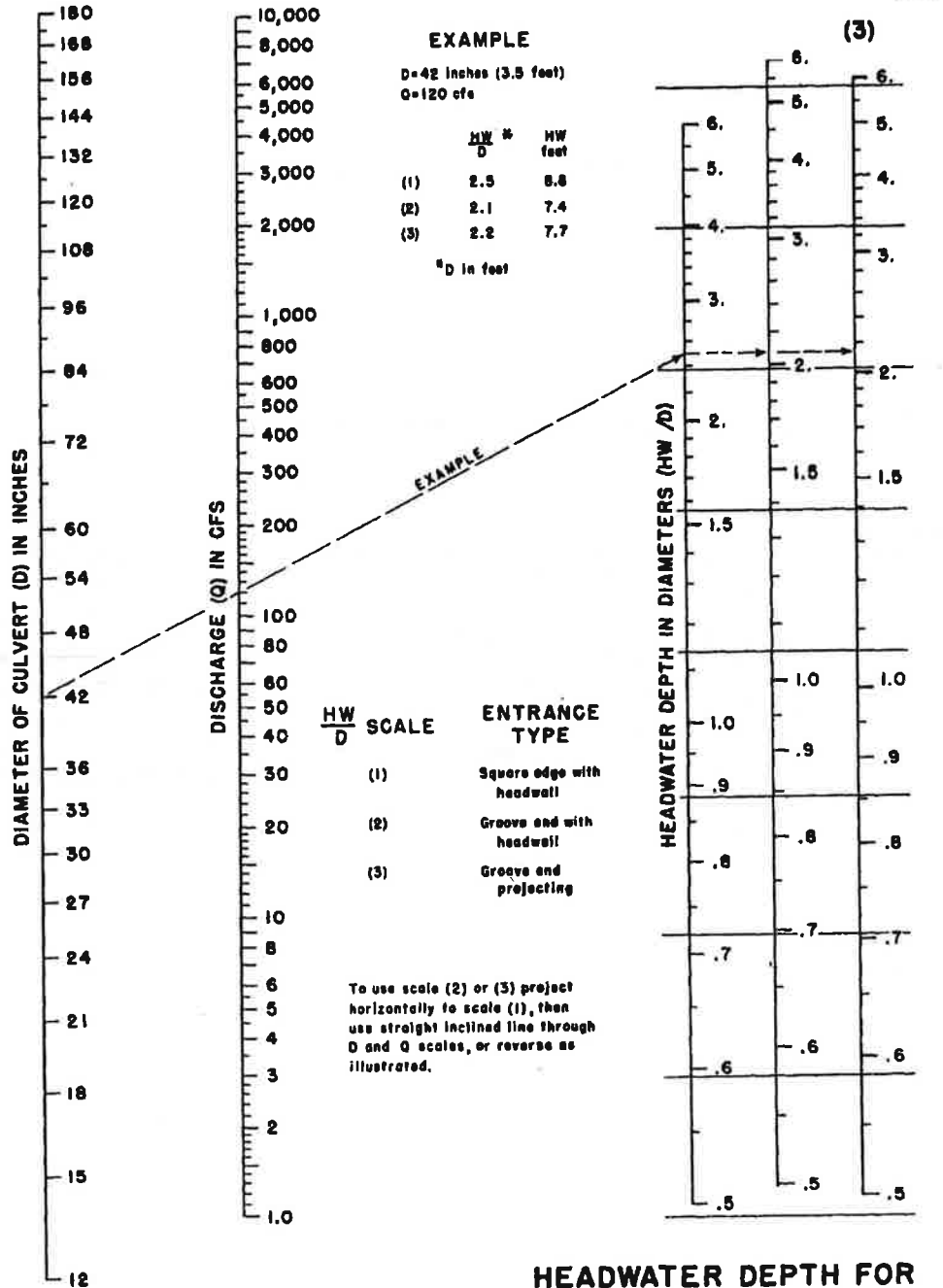

HEADWATER DEPTH FOR CONCRETE PIPE CULVERTS WITH INLET CONTROL

HEADWATER SCALES 2&3
REVISED MAY 1964

BUREAU OF PUBLIC ROADS JAN. 1963

Figure 1000-7 Common Nomographs

CHART 2B

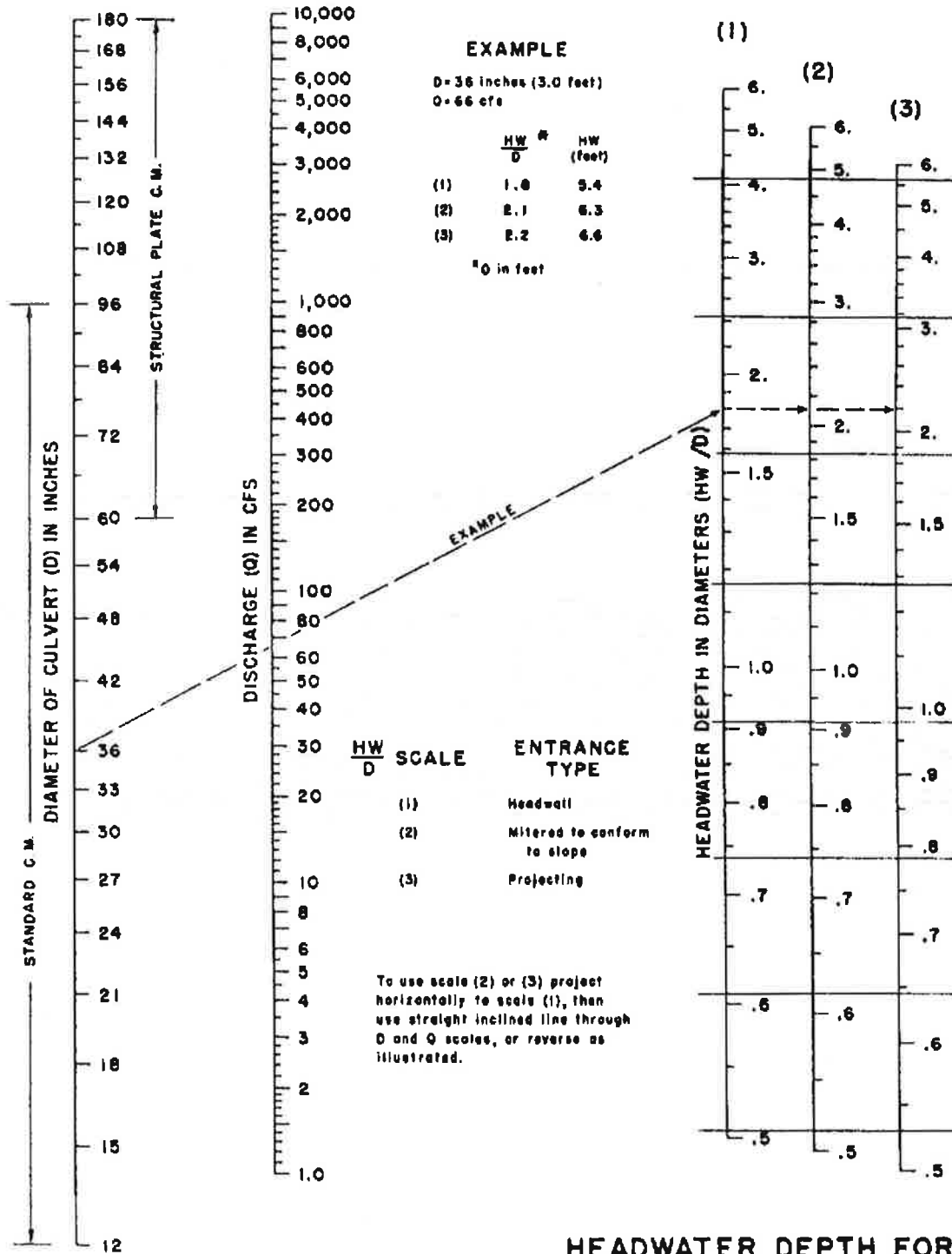

HEADWATER DEPTH FOR C. M. PIPE CULVERTS WITH INLET CONTROL

Figure 1000-7 Common Nomographs

CHART 5B

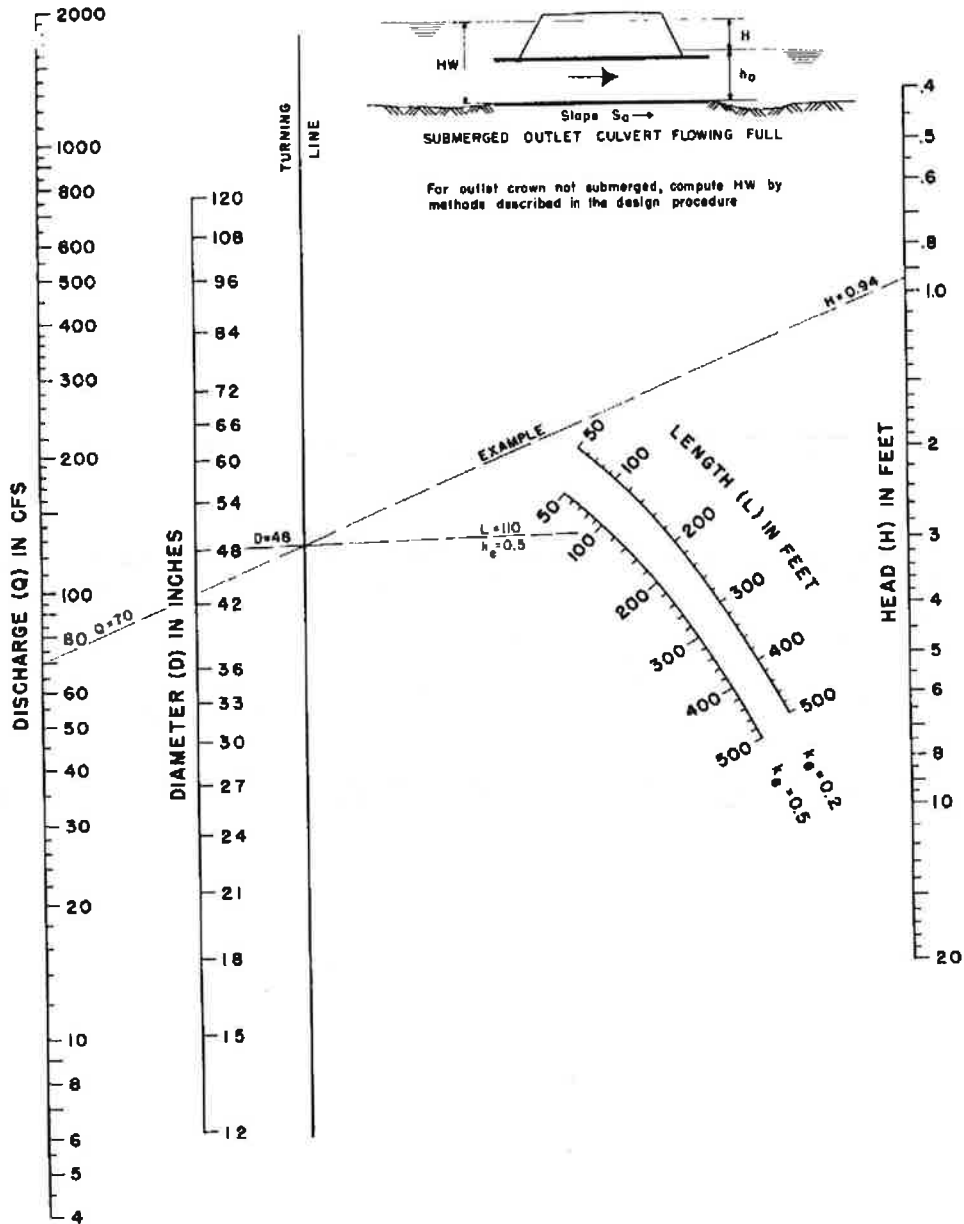

HEAD FOR
CONCRETE PIPE CULVERTS
FLOWING FULL
 $n = 0.012$

BUREAU OF PUBLIC ROADS JAN. 1963

Figure 1000-7 Common Nomographs

CHART 6B

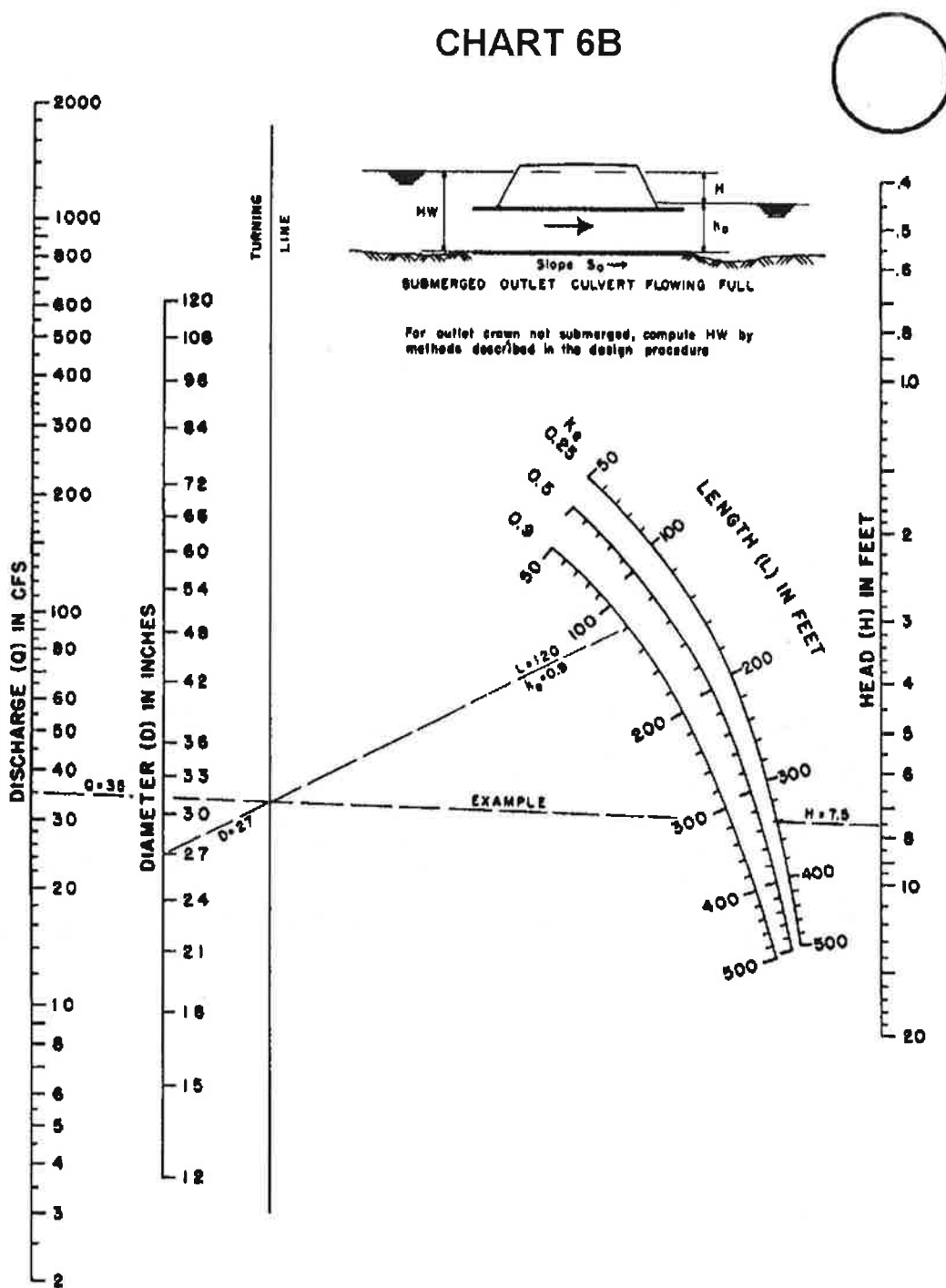

**HEAD FOR
STANDARD
C. M. PIPE CULVERTS
FLOWING FULL
 $n = 0.024$**

Figure 1000-7 Common Nomographs

CHART 8B

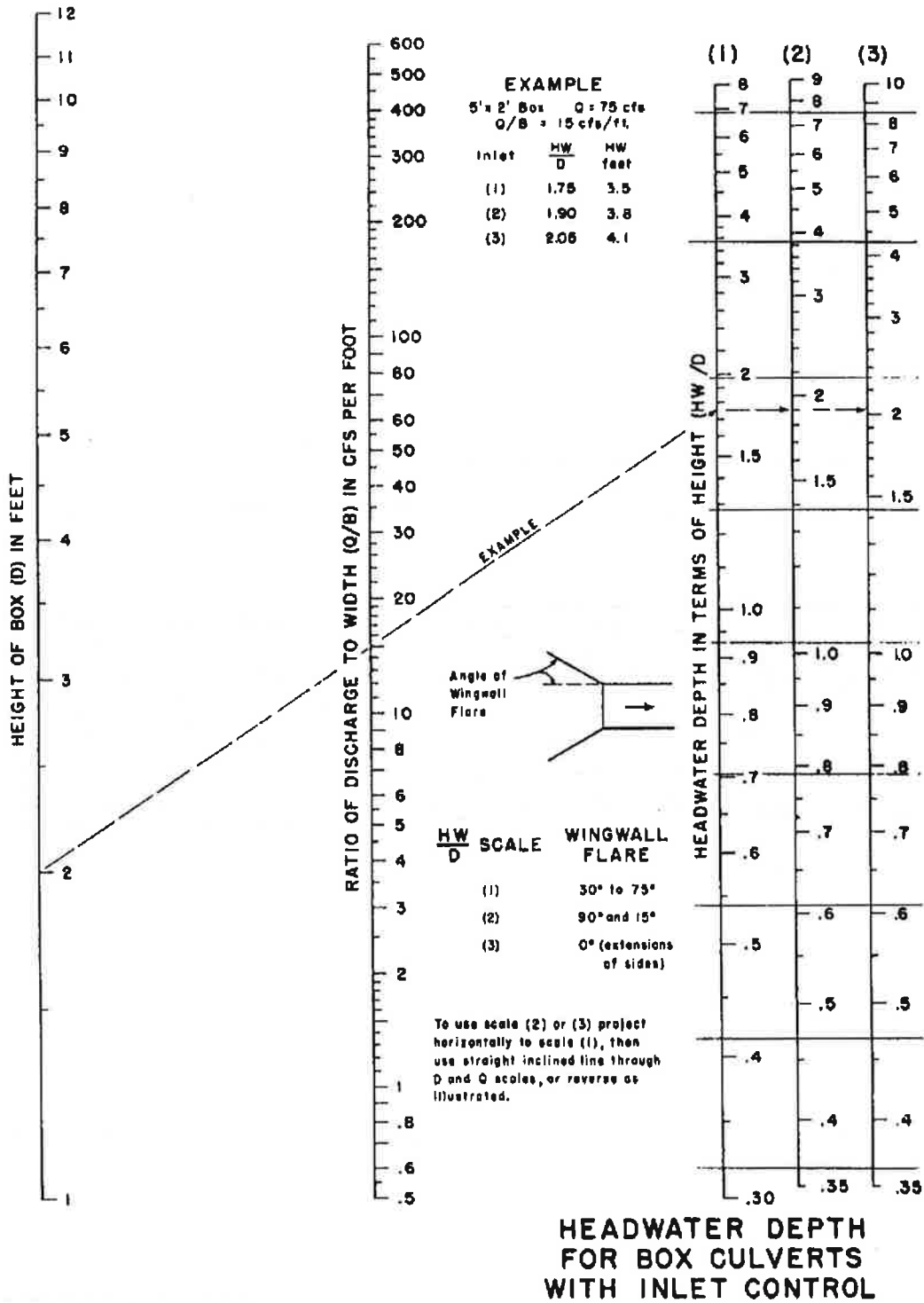

BUREAU OF PUBLIC ROADS JAN. 1963

Figure 1000-7 Common Nomographs

CHART 9B

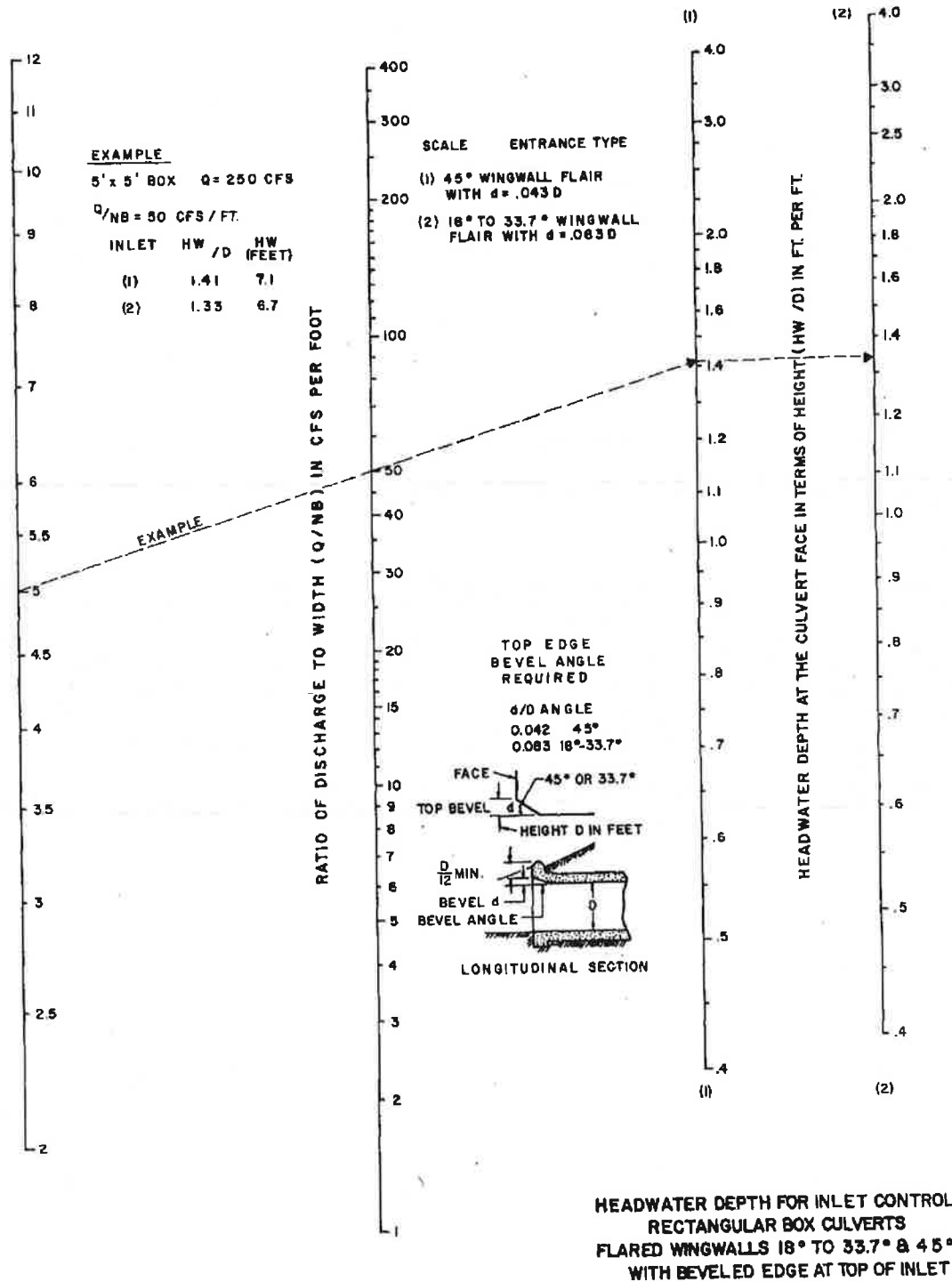

Figure 1000-7 Common Nomographs

CHART 10B



EXAMPLE

B=7 FT. D=5 FT. Q=500 CFS Q/NB = 71.5

ALL EDGES	HW	HW
	D	feet
CHAMFER 3/4"	2.31	11.5
1/2 IN/FT BEVEL	2.09	10.4
1 IN/FT BEVEL	1.88	9.4

INLET FACE—ALL EDGES:

1 IN/FT. BEVELS 33.7° (1:1.5)

1/2 IN/FT BEVELS 45° (1:1)

3/4 INCH CHAMFERS

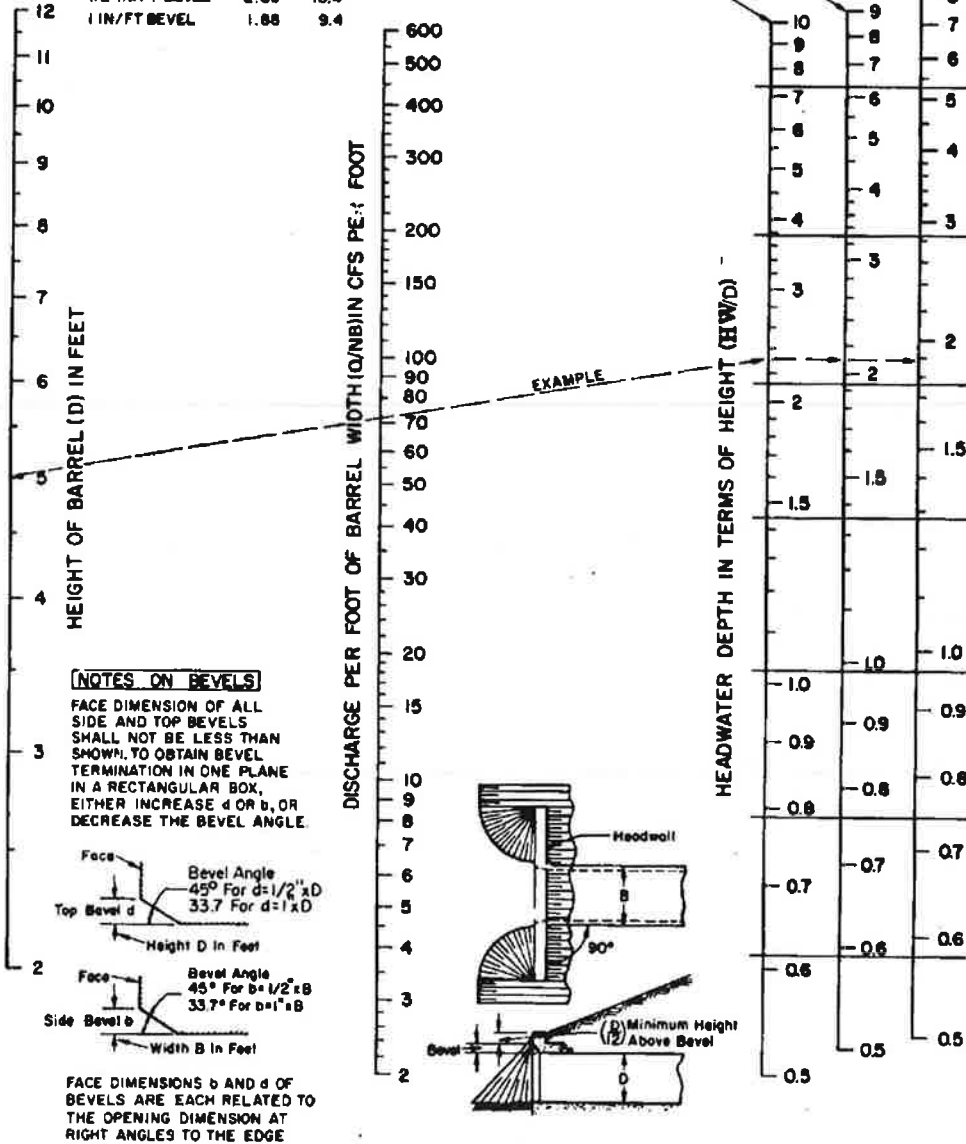

**HEADWATER DEPTH FOR INLET CONTROL
 RECTANGULAR BOX CULVERTS
 90° HEADWALL
 CHAMFERED OR BEVELED INLET EDGES**

FEDERAL HIGHWAY ADMINISTRATION
 MAY 1973

Figure 1000-7 Common Nomographs

CHART 11B

EXAMPLE

B=7 FT. D=5 FT. Q=500 CFS

EDGE & SKEW	HW	HW
3/4" CHAMFER	D	feet
45°	2.51	12.5
30°	2.43	12.1
15°	2.36	11.8
VARIED BEVEL		
10° TO 45°	2.07	10.3

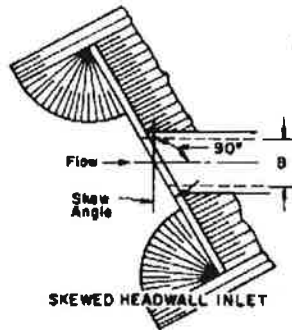
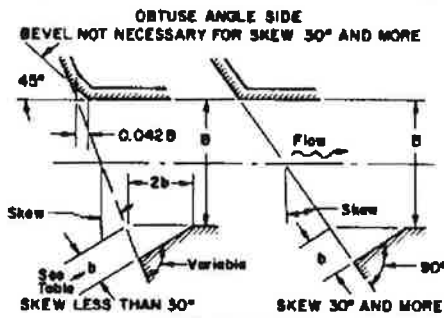
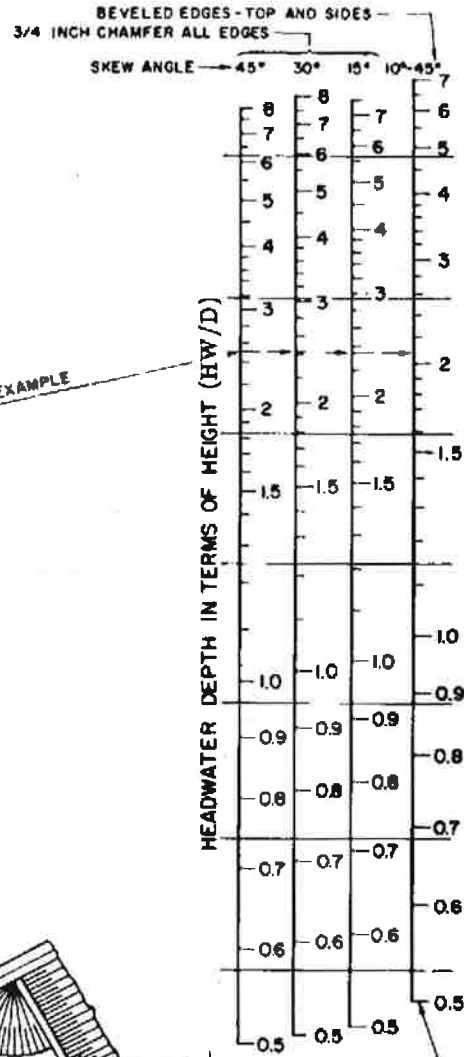
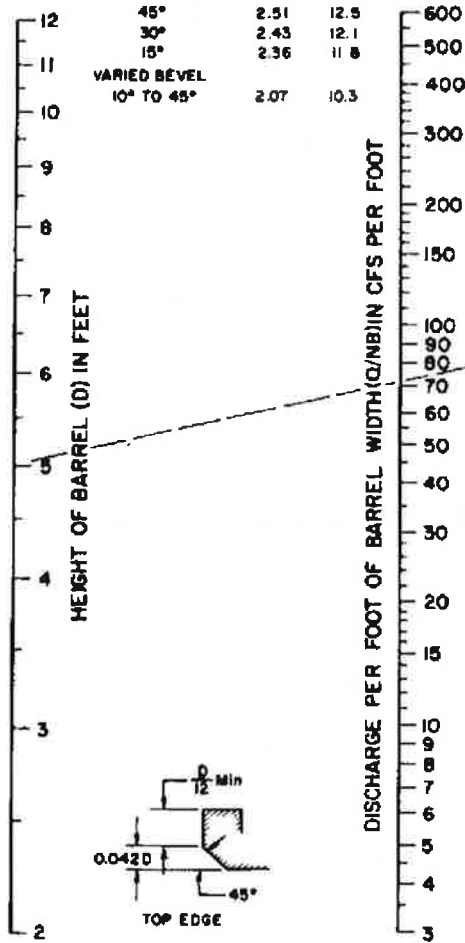

BEVELED EDGES AS DETAILED

SKEW ANGLE	SIDE BEVEL b
10°	3/4" x B (H)
15°	1" x B
22-1/2°	1-1/4" x B
30°	1-1/2" x B
37-1/2°	2" x B
45°	2-1/2" x B

HEADWATER DEPTH FOR INLET CONTROL SINGLE BARREL BOX CULVERTS SKEWED HEADWALLS CHAMFERED OR BEVELED INLET EDGES

FEDERAL HIGHWAY ADMINISTRATION
MAY 1973

Figure 1000-7 Common Nomographs

CHART 12B

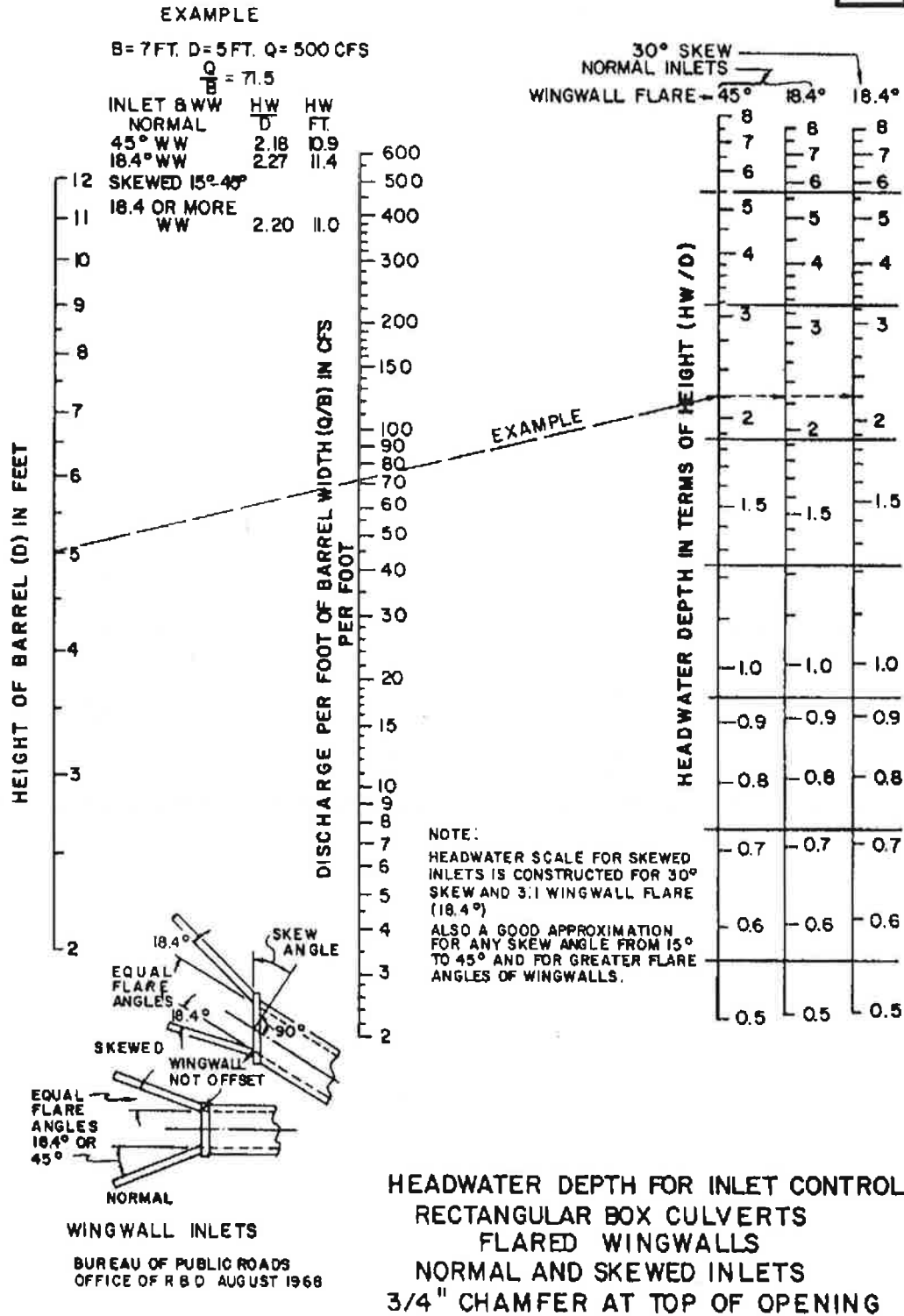

Figure 1000-7 Common Nomographs

CHART 13B

EXAMPLE

B = 7 FT. D = 5 FT. Q = 600 C.F.S.
 $\frac{Q}{B} = 71.5$

WINGWALL TOP EDGE
 FLARE ANGLE BEVEL $\frac{HW}{D}$ HW
 FT. FT.

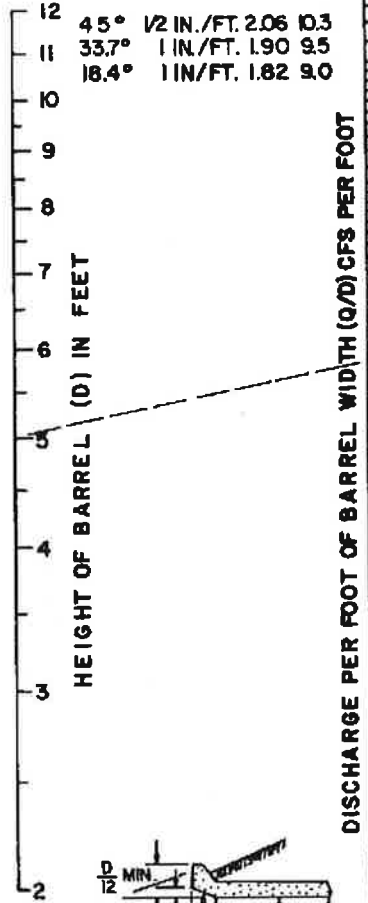

18.4° WW & d = 0.083D
 33.7° WW & d = 0.083D
 45° WW & d = 0.042D

TOP EDGE
 BEVEL ANGLE
 REQUIRED

ANGLE
 0.042 45°
 0.083 33.7°

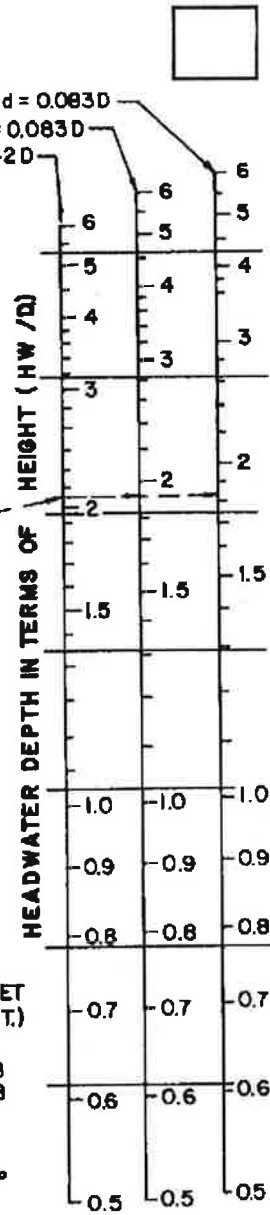

WINGWALLS

FLARE	ANGLE	MIN. OFFSET
1:1	45°	3/4" x B (FT.)
1:1.5	33.7°	1" x B
1:2	26.6°	1-1/4" x B
1:3	18.4°	1-1/2" x B

* USE 33.7° & 0.083D TOP
 EDGE BEVEL AND READ
 HW ON SCALE FOR 18.4°
 WW

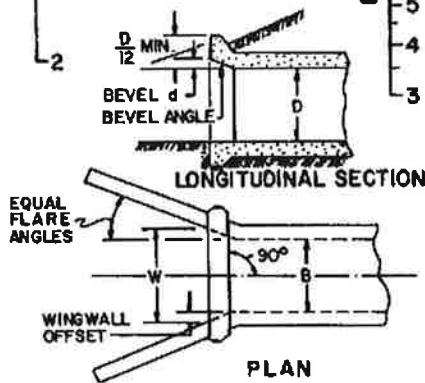

BUREAU OF PUBLIC ROADS
 OFFICE OF R & D AUGUST 1968

HEADWATER DEPTH FOR INLET CONTROL
 RECTANGULAR BOX CULVERTS
 OFFSET FLARED WINGWALLS
 AND BEVELED EDGE AT TOP OF INLET

Figure 1000-7 Common Nomographs



CHART 15B

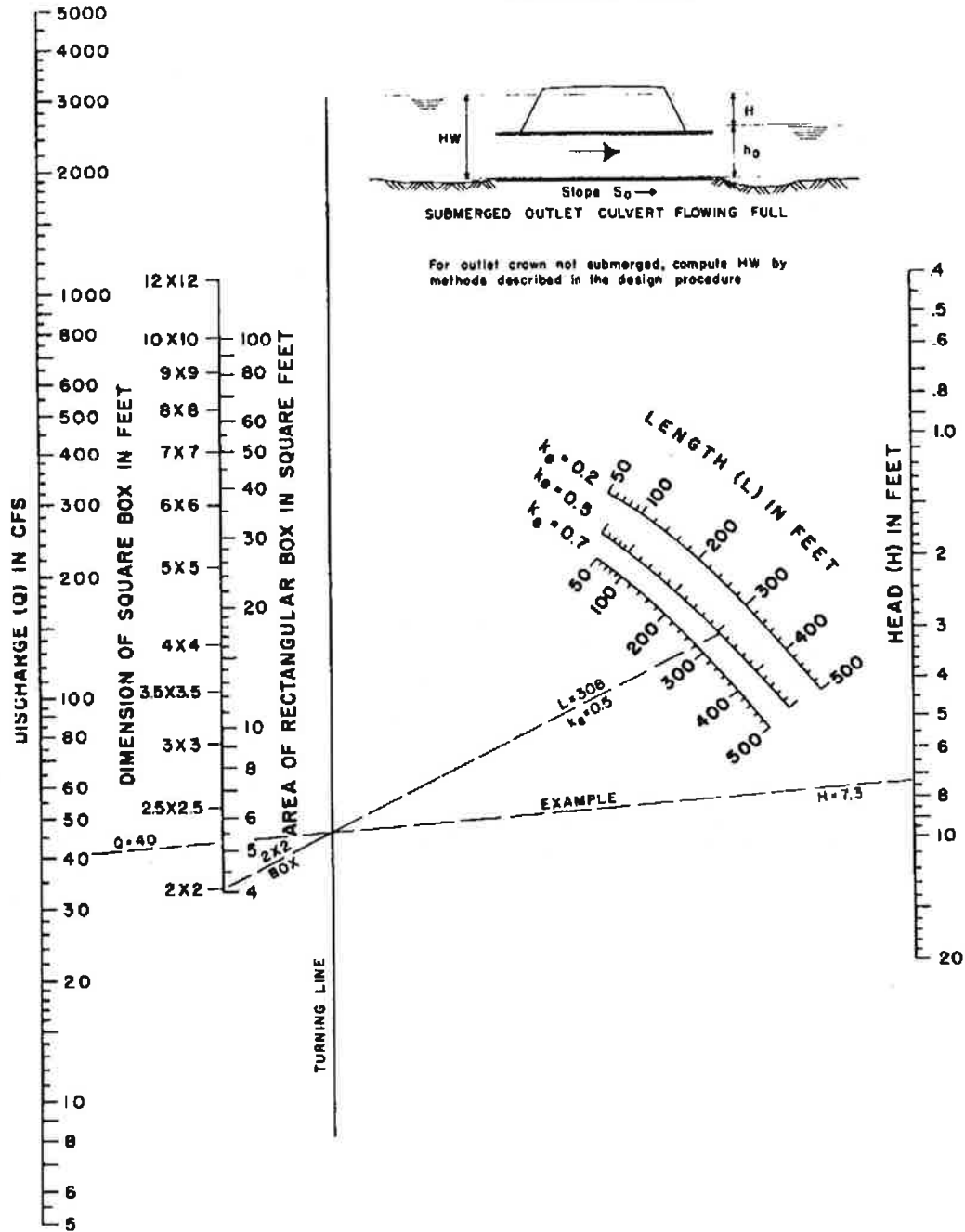

HEAD FOR
CONCRETE BOX CULVERTS
FLOWING FULL
 $n = 0.012$

Figure 1000-7 Common Nomographs

CHART 29B

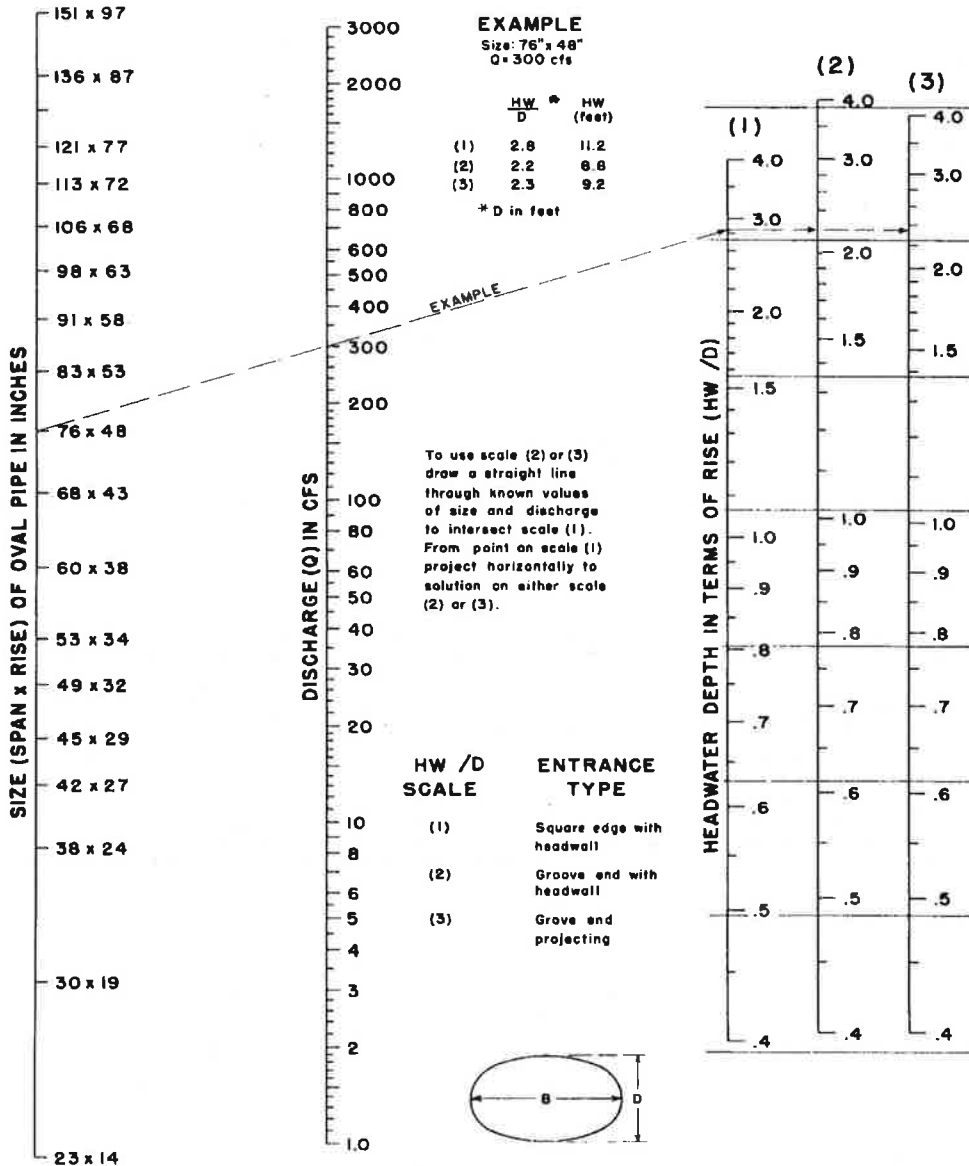

HEADWATER DEPTH FOR OVAL CONCRETE PIPE CULVERTS LONG AXIS HORIZONTAL WITH INLET CONTROL

BUREAU OF PUBLIC ROADS JAN. 1963

Figure 1000-7 Common Nomographs

CHART 33B

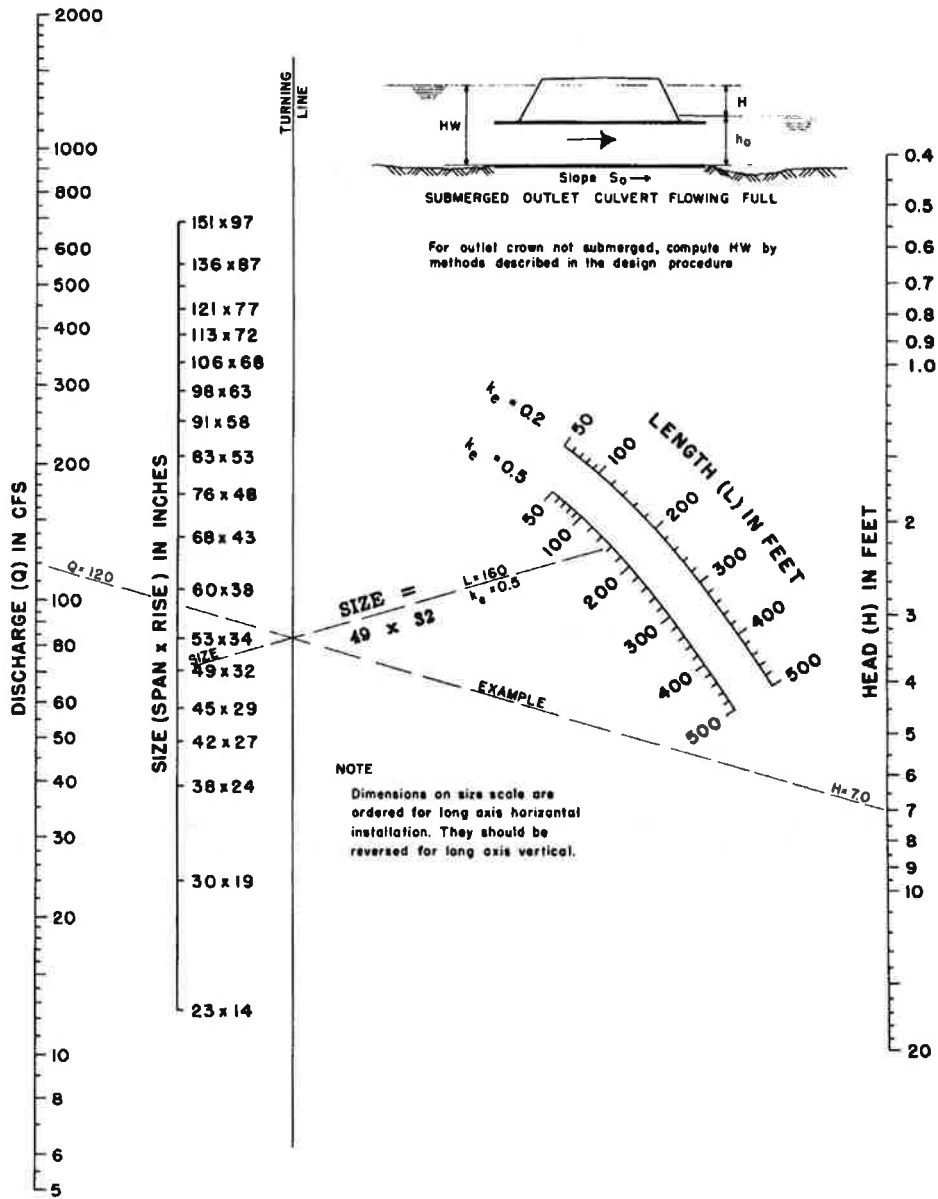

HEAD FOR
OVAL CONCRETE PIPE CULVERTS
LONG AXIS HORIZONTAL OR VERTICAL
FLOWING FULL
 $n = 0.012$

BUREAU OF PUBLIC ROADS JAN. 1963

Figure 1000-11 – Low Water Crossing Design Example

Step 1 Calculating Existing 100-Year WSEL

100-Yr WSEL (ft.)	Depth (ft.)	Area (ft.)	Wetted Perimeter (ft.)	Hydraulic Radius (ft.)
5404.0	4.0	65.0	38.59	1.685
5405.0	5.0	111.0	58.68	1.891
5406.0	6.0	177.0	78.78	2.247
5407.0	7.0	263.0	98.88	2.660
5408.0	8.0	369.0	119.0	3.101

$$Q = \frac{1.49}{n} AR^{2/3} S^{1/2}$$

$$1431 \text{ cfs} = \frac{1.49}{0.04} (177)(2.247)^{2/3} (0.016)^{1/2}$$

Step 3 Calculating Proposed Road Grade Elevation

Road Deck Elev (ft.)	Area (ft.)	Wetted Perimeter (ft.)	Hydraulic Radius (ft.)	Discharge (cfs)
5403.0	224.0	96.40	2.324	1852
5403.5	213.5	96.35	2.216	1710
5404.0	198.0	96.30	2.056	1509
5404.1	194.3	96.29	2.018	1462
5404.2	190.4	96.28	1.978	1413
5404.5	177.5	96.25	1.844	1258
5405.0	152.0	96.20	1.580	971.6

$$1462 \text{ cfs} = \frac{1.49}{0.04} (194.3)(2.018)^{2/3} (0.016)^{1/2}$$

Channel Geometry (Not to Scale)

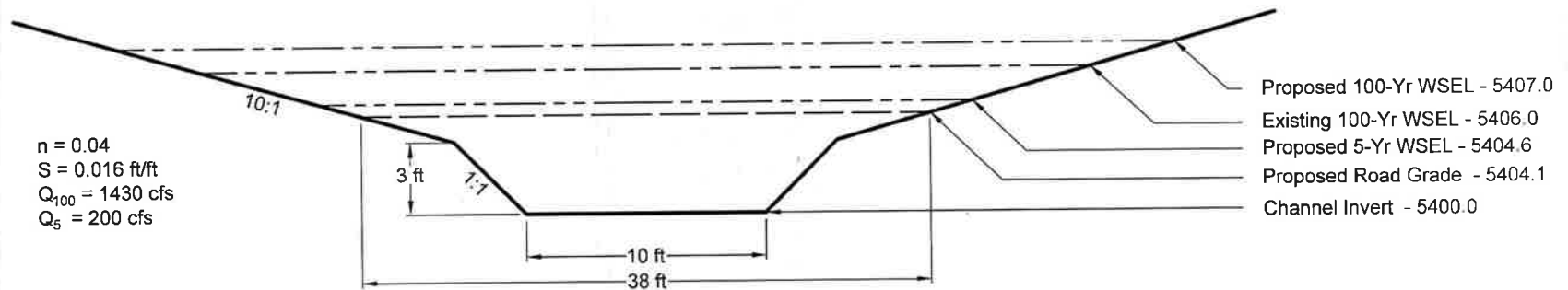

Section 1100 Hydraulic Structures

Table of Contents

1101 INTRODUCTION	1100-1
1102 SLOPING DROP STRUCTURES	1100-1
1103 VERTICAL DROP STRUCTURES	1100-1
1104 LOW FLOW DROP STRUCTURES AND CHECK STRUCTURES	1100-2
1105 CULVERT RUNDOWNS	1100-3
1106 ENERGY DISSIPATORS	1100-3
1107 RAW WATER DITCH CROSSINGS	1100-4
1108 ACCESS, SAFETY, AND ENVIRONMENTAL IMPACT	1100-4
1109 REFERENCES	1100-5

List of Figures

1100-1 Schematic Roadside Ditch Check Structure	1100-2
1100-2 Example of a USBR Type VI Impact Stilling Basin	1100-3

Section 1100 Hydraulic Structures

1101 INTRODUCTION

This MANUAL defines hydraulic structures as structures that control storm runoff during a condition of rapid directional change or rapid acceleration or deceleration of velocity. These structures include drop structures, check structures, rundowns and energy dissipators for pipe outfalls, and raw water ditch crossings. Culverts, bridges, weirs, and channel bends also cause rapid changes in velocity, but these are discussed in other sections of this MANUAL.

Because each hydraulic structure is site specific, the criteria in this section are somewhat generalized. The design of channel drops, checks, and rundowns within the Denver and Boulder metropolitan areas has evolved considerably over the last few decades due to performance evaluations and maintenance concerns. It is reasonable to assume that the design of these structures will continue to be refined over time. This section relies heavily on design guidance in the USDCM (UDFCD, 2016) so that Boulder County can benefit from the ongoing performance evaluations of recently constructed channel drops, checks, and rundowns.

This section will also include discussion on aspects of design that are often neglected, but play an important role in the overall function and lifespan of a structure. These include safety, access, and environmental considerations. Coordinating with the County Engineer is strongly encouraged when planning and designing hydraulic structures.

1102 SLOPING DROP STRUCTURES

The design, specifications, and criteria for all sloping drop structures within Boulder County shall be in accordance with the most recent version of the USDCM. All sloping drops shall be grouted sloping boulder (GSB) drops unless a Design Exception is granted for the use of sculpted concrete where specific aesthetic concerns may justify its use. Construction quality control and oversight is a key component to the successful installation of any drop structure. Care should be taken during construction to ensure that the drop is constructed in strict accordance with the design plans and specifications. Minor modifications to the design of GSB drops may be incorporated to allow for fish passage and to minimize impacts to macroinvertebrates, especially on perennial streams, with the approval of the County Engineer, which is discussed more at the end of this section.

1103 VERTICAL DROP STRUCTURES

Vertical drop structures are generally discouraged because they can cause dangerous hydraulic conditions and require extensive maintenance. Vertical drop structures should not be used on a channel where fish passage is a concern or where the design flow exceeds 500 cfs or a unit discharge of 35 cfs per foot (cfs/ft). These structures may be acceptable in locations where the drop footprint needs to be minimized and where there is a very low chance of access by minors. If a vertical drop structure is

allowed, the net drop structure height should be limited to 2 feet. A stilling basin 1 foot deep should be constructed immediately downstream of the crest. The design procedure for a vertical drop structure can be found in *Open Channel Hydraulics* (Chow, 1959) for a straight drop spillway. This procedure is also provided for reference in the USDCM.

1104 LOW FLOW DROP STRUCTURES AND CHECK STRUCTURES

Low flow drop structures and check structures may be used when a channel has not yet experienced significant erosion and degradation, but is anticipated to degrade in the future. The criteria and design guidance in the USDCM may be used for low flow drop structures and check structures on major drainageways.

Where roadside ditches require check structures to maintain their stability, a lesser degree of protection is needed, as the forces associated with flows in roadside ditches are considerably less than those in a major drainageway. Figure 1100-1 is a schematic of a roadside ditch check that may be used in the county. Roadside ditch checks can be used to flatten proposed ditch slopes or where erosion is already apparent in a retrofit scenario.

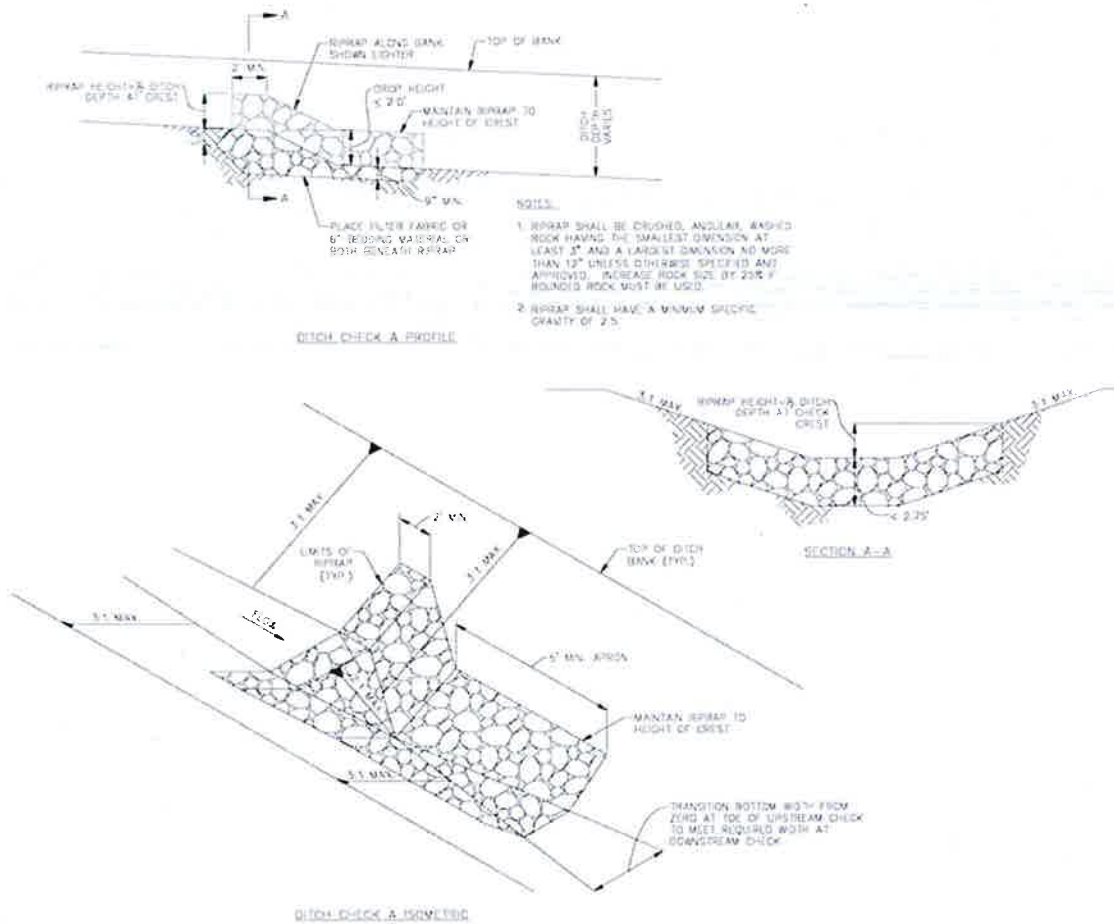

Figure 1100-1. Schematic Roadside Ditch Check Structure.

1105 CULVERT RUNDOWNS

When a culvert or storm drain discharges above a channel invert, a riprap rundown has historically been constructed to convey the water from the pipe outlet to the channel invert. Culvert rundown installations have a very high rate of failure and are not permitted in Boulder County without a Design Exception. If the culvert or storm drain cannot be designed to discharge within 1 foot of the channel invert, a pipe should be used to convey flows to just above the channel invert. Appropriate energy dissipation in the form of a riprap apron, low tailwater basin, or Type VI stilling basin should be used at the pipe outlet to prevent erosion at the pipe outlet.

1106 ENERGY DISSIPATORS

Energy dissipators are required at channel drops when the unit discharge exceeds 35 cfs/ft and at the outlet of culverts or storm sewers when the velocity exceeds 16 fps. The USBR Type III and USBR Type IX energy dissipators are approved for use in Boulder County for spillways and channels, and the USBR Type VI is approved for pipe outlets. Comprehensive design guidance for each of these structures can be found in the *Hydraulic Design of Stilling Basins and Energy Dissipators* (USBR, 1987) and is included in HEC-14 (Thompson and Kilgore, 2006). Figure 1100-2 is a photograph of a Type VI impact basin in Colorado.



Figure 1100-2. Example of a USBR Type VI Impact Stilling Basin (CDOT, 2004).

1107 RAW WATER DITCH CROSSINGS

A structure shall be constructed at all raw water ditch crossings to separate peak storm runoff from irrigation and other raw water delivery flows unless otherwise permitted. Three types of structures are recognized to achieve this requirement.

1. Type 1 structures result in complete separation of storm flows and raw water flows. This type of control is often used for smaller ditches or where intermingling of storm and raw water flows would cause water quality concerns. Type I structures are typically an irrigation flume crossing of a gulch or a pipe to convey storm flows under the ditch.
2. Type 2 structures discharge storm flows into the raw water ditch and then release excess flows into the drainageway downstream via a formal control structure. This type of control is often used where the ditch has water rights on the stream in question, in which case not all storm flows may need to be returned to the drainageway. This type of control could also be used where the ditch does not have water rights on the stream in question, in which case all storm flows would have to be returned to the drainageway. In this latter case, the type of structure required may be very difficult to design and operate to meet all regulatory requirements. The requirements for this type of structure may be less expensive than complete flow separation, especially for larger drainageways.
3. Type 3 structures discharge runoff into the raw water ditch without returning the runoff peak back to the drainageway. This type of structure requires a thorough analysis of the ditch capacity and the storm runoff peaks and volumes and may require a detention pond to reduce the runoff to what the ditch is capable of conveying.

A typical ditch crossing does not exist because each raw water ditch crossing a drainageway will have its own unique design and requirements. When a raw water ditch crossing structure is required, the applicant shall meet with the County Engineer and the ditch owner(s) to develop specific design requirements for the structure, and shall obtain written approval of the design from the raw water ditch owner(s).

1108 ACCESS, SAFETY, AND ENVIRONMENTAL IMPACT

Drop structures are constructed to dissipate the erosive forces of water at specific locations to limit those forces in the rest of the channel. The focus is traditionally on the hydraulic design of the structure, but other considerations play an important role in how the structure will interact with other aspects of its surroundings besides simply the physical force of the water.

Maintenance access must be provided to each drop structure constructed in Boulder County. Routine inspection and maintenance will ensure the structure is performing as it should and could catch any structure failures early enough to prevent more expensive rehabilitation. The county should be consulted early in the design process to identify maintenance access requirements.

Channels may be used by kayakers, paddle boarders, or swimmers or are enjoyed by hikers or campers who may venture to the water's edge. Drop structures should be designed in a way that is consistent with the requirements for recreational user safety. Drop structures in boatable channels should incorporate a boat chute, bypass, or full river passage to allow passage for boats.

Fish passage through drop structures and consideration of macroinvertebrate habitat is critical in certain channels. Colorado Parks and Wildlife, the US Fish and Wildlife Service, or other local agency can establish the need to provide fish passage and specific site requirements. Regulatory requirements and project objectives generally should be established early, but additional requirements may arise during the 404 permitting process. Features that improve habitat and offer fish passage can include creating currents that encourage passage, avoiding sediment deposition, avoiding shallow zones, and providing resting areas. Features should be designed to accommodate behaviors and capabilities of target species. When fish passage or habitat is an important design element or a permit requirement, specialists in fish passage should be included on the design team.

Where both fish and boat passage is desired, inclusion of integral fish passage features into boatable drop structures is feasible. This usually results in a roughened channel type of fish passage such as a rock ramp or riffle-pool fishway. Roughened channel fish passages can be readily included into boatable drop structures, but the specific criteria depend on the target species and other related factors.

1109 REFERENCES

Chow, V. T., 1959. *Open Channel Hydraulics*, McGraw-Hill College, Burr Ridge, IL.

Colorado Department of Transportation, 2004. "Chapter 11, Energy Dissipators," *Drainage Design Manual*, prepared by the Colorado Department of Transportation, Denver, CO.

Thompson, P. L. and R. T. Kilgore, 2006. *Hydraulic Design of Energy Dissipators for Culverts and Channels, Hydraulic Engineering Circular No. 14, Third Edition*, FHWA-NHI-06-086 HEC 14, prepared by the Federal Highway Administration, Arlington, VA.

Peterka, A. J., 1987. *Hydraulic Design of Stilling Basins and Energy Dissipators*, U.S. Bureau of Reclamation, Washington, DC.

Urban Drainage and Flood Control District, 2016. *Urban Storm Drainage Criteria Manual: Volume 2 Structures, Storage, and Recreation*, prepared by the Urban Drainage and Flood Control District, Denver, CO.

Section 1200 Detention and Permanent Water Quality

Table of Contents

1201 INTRODUCTION	1200-1
1202 LOW IMPACT DEVELOPMENT	1200-1
1203 DETENTION.....	1200-1
1203.1 Detention and Development	1200-1
1203.2 Design of Detention Facilities	1200-2
1203.3 Maintenance of Detention Facilities	1200-2
1203.4 Detention and Water Rights	1200-2
1204 PERMANENT WATER QUALITY.....	1200-3
1204.1 Permanent Water Quality and Development	1200-3
1204.2 Permanent Water Quality Treatment for Impairments and TMDLs	1200-4
1204.3 Permanent Water Quality Treatment within Detention Basins.....	1200-4
1204.4 Additional Permanent Water Quality Treatment Options.....	1200-4
1204.4.1 Volume-Based Facilities	1200-4
1204.4.2 Flow-Based Facilities	1200-4
1204.4.3 Proprietary Treatment.....	1200-5
1204.5 Maintenance Requirements.....	1200-5
1205 REFERENCES	1200-6

Section 1200 Detention and Permanent Water Quality

1201 INTRODUCTION

This section presents the criteria for design and evaluation of all detention and water quality facilities for Boulder County. The main purpose of a detention facility has historically been to store the excess storm runoff associated with increased basin imperviousness and discharge this excess at a rate similar to the rate experienced before development. In recent years, detention facilities have also frequently been viewed as a unique opportunity to improve the water quality of runoff coming from developed areas. This runoff typically carries higher levels of nitrogen, phosphorus, and sediment that can damage the ecosystems of the natural streams downstream of the development.

This section discusses detention both with and without a water quality component; water quality facilities located outside a detention basin, including proprietary facilities; and when detention and water quality are required.

1202 LOW IMPACT DEVELOPMENT

Boulder County requires low impact development (LID) principles to be followed for all new and redevelopment by minimizing directly connected impervious areas (MDCIA). MDCIA can be accomplished by routing runoff from impervious surfaces over pervious areas to decrease runoff velocities and promote infiltration. At least 20 percent of the total impervious area of all new development and redevelopment sites must first drain to a pervious area equal to at least 10 percent of the total impervious surface area of the development site, prior to discharging from the site.

In addition to the benefits of decreasing runoff velocities and promoting infiltration, the Water Quality Capture Volume (WQCV), Excess Urban Runoff Volume (EURV), and 100-year detention volume can all be calculated using the effective imperviousness value that results from the use of LID. Effective imperviousness shall be calculated in accordance with the USDCM (UDFCD, 2016). A lower effective imperviousness will then result in smaller required water quality and detention volumes.

1203 DETENTION

This section presents circumstances under which stormwater detention is required with development, the criteria for detention basin design, and maintenance requirements of detention basins.

1203.1 Detention and Development

Full-spectrum detention is required for all new development and redevelopment. Subdivided development may use a single detention facility provided it captures runoff from the entire

development. Exceptions to the detention requirement may be granted if the project has any of the following characteristics, provided the new or additional undetained runoff will cause no adverse impacts to any downstream properties.

1. Parcels that are 3 acres or larger, have one single-family dwelling, and have a total imperviousness of less than 10 percent
2. Additions to buildings where the total impervious area, both existing and proposed, covers less than 5,000 square feet of impervious paved and roof surfaces
3. Fill areas that are not paved over or otherwise made impervious
4. Other situations as may be determined by the County Engineer to be in the best interest of the county.

Exceptions may also be granted for slightly smaller single-family residential parcels provided low-impact development principles are included in the design. These may include using pervious pavers or pavement for driveways and walkways and routing roof drainage across a vegetated pervious area prior to discharging it to a roadside ditch or stream. An exemption to provide detention issued by Boulder County does not eliminate potential liability to others. All detention facilities in the county are subject to oversight by the county.

1203.2 Design of Detention Facilities

The UDFCD has invested a significant amount of energy into developing detailed design guidance for detention basins. The USDCM (UDFCD, 2016) provides discussion on the applicability of regional, subregional, and on site detention; an explanation for why full-spectrum detention is the preferred approach; and calculations for sizing the pond volume and designing the outlet structure. The USDCM shall be used for sizing and designing all detention basins for full-spectrum detention in Boulder County. Detention facilities may include extended detention basins, constructed wetlands, sand filters, and rain gardens. The USDCM also includes weir and orifice equations for the design of detention basin outlets that may also be used for other applications within this MANUAL as needed.

1203.3 Maintenance of Detention Facilities

The performance of detention facilities is extremely sensitive to a lack of maintenance. Detention facility outlets in particular must be regularly maintained to ensure the basins meet the requirements of Colorado water law and do not detain water longer than allowable. If detention is to be constructed, Boulder County requires an enforceable maintenance agreement to be in place before issuing any applicable local permits. The agreement must include the party responsible for maintaining the facility, inspection frequency, and proposed maintenance activities.

1203.4 Detention and Water Rights

Senate Bill 15-212 became effective on August 5, 2015, as Colorado Revised Statute (CRS) §37-92-602 (8), *Concerning a Determination that Water Detention Facilities Designed to Mitigate the Adverse Effects of Storm Water Runoff Do Not Materially Injure Water Rights*. This statute provides legal protection for any stormwater detention and infiltration facility in Colorado, provided the facility does not materially injure water rights and meets the following criteria that are applicable in Boulder County.

1. It is owned or operated by a governmental entity or is subject to oversight by a governmental entity.
2. It continuously releases or infiltrates at least 97 percent of all of the runoff from a rainfall event that is less than or equal to a 5-year storm within 72 hours after the end of the event.
3. It continuously releases or infiltrates as quickly as practicable, but in all cases releases or infiltrates at least 99 percent of the runoff within 120 hours after the end of events greater than a 5-year storm.
4. It operates passively and does not subject the stormwater runoff to any active treatment process such as coagulation, flocculation, and disinfection.

There are reporting requirements for any owner or operator of any detention facility constructed after August 5, 2015 that seeks protection under the new statute. A data sheet and online map-based compliance portal website has been developed that will allow owners and operators in Boulder County to upload the required notification information. The notification requirement applies only to facilities constructed after August 5, 2015. Facilities in existence before August 5, 2015, are defined in the statute as materially noninjurious to water rights and do not require notification. A guidance document from the State Engineer that further clarifies the requirements of Senate Bill 15-212 can be found online (<http://water.state.co.us/DWRIPub/Documents/DWR%20Storm%20Water%20Statement.pdf>) or via an internet search for "Senate Bill 15-212 state engineer guidance."

The compliance portal can be found online (<https://maperture.digitaldataservices.com/qvh/?viewer=cswdif>). A document containing frequently asked questions, links to a video tutorial, and the link to the compliance portal can be found online (<http://www.crqov.com/DocumentCenter/View/12225>) or via an internet search for "Colorado water rights compliance portal." The owner or operator must report new detention via the portal, and the county must approve the portal entry once it is complete. The owner or operator shall inform the county once the portal documentation is ready for approval.

1204 PERMANENT WATER QUALITY

This section presents circumstances under which permanent water quality facilities are required with development; the options available to provide permanent water quality treatment; and maintenance requirements associated with permanent water quality facilities. Permanent water quality can be provided with a volume-based approach by capturing and slowly releasing the Water Quality Capture Volume (WQCV). Other mechanisms used to provide water quality treatment do not utilize the WQCV and instead use filtration, infiltration, sorption, or biological processes to reduce pollutants.

1204.1 Permanent Water Quality and Development

Permanent water quality treatment is required for all new development and redevelopment. Where detention is required, permanent water quality treatment shall be included within the detention facility. Exceptions to the permanent water quality requirement may be granted if the project has any of the following characteristics:

1. Residential development density that does not exceed one single-family dwelling per 3 acres
2. Residential projects with a total imperviousness less than 10 percent for any given acre
3. Residential development on sites smaller than 0.5 acre

4. Exclusions from post-construction stormwater management provided by the most recent MS4 permit
5. Other situations as may be determined by the County Engineer to be in the best interest of the county.

Exceptions may also be granted provided low-impact development principles are included in the design. These may include the using pervious pavers or pavement for driveways and walkways and routing roof drainage across a vegetated pervious area prior to discharging it to a roadside ditch or stream. All permanent water quality facilities in Boulder County are subject to oversight by the county.

1204.2 Permanent Water Quality Treatment for Impairments and TMDLs

Where new development or redevelopment is located within an area that drains to an impaired waterbody on the 303(d) list, or to a waterbody with an approved TMDL, the county requires that permanent water quality facilities be selected based on their effectiveness at treating the pollutants of concern, to the extent practicable. The selection process should reference data available from the International Stormwater BMP database, available online (<http://www.bmpdatabase.org/>).

1204.3 Permanent Water Quality Treatment within Detention Basins

When detention facilities are designed to provide full-spectrum detention, the WQCV can be accommodated within the volume of the pond, without the need for additional volume to treat water quality. The WQCV can be treated in Boulder County in extended detention basins, constructed wetland ponds, sand filters, and rain gardens. The sizing and design of water quality facilities within detention basins shall be in accordance with the most recent version of the USDCM.

1204.4 Additional Permanent Water Quality Treatment Options

Multiple methods to treat water quality do not rely on using a part of a large detention basin. These include volume-based treatment in basins that are only large enough to treat the WQCV and flow-based treatment facilities that utilize mechanisms other than sedimentation. Design of permanent water quality facilities outside of a full-spectrum detention facility in Boulder County shall be in accordance with the latest version of the USDCM unless otherwise noted.

1204.4.1 Volume-Based Facilities

Facilities that rely on capturing the WQCV and releasing it slowly are volume-based facilities. These include rain gardens, sand filter basins, and green roofs. They typically provide very good sediment removal and moderate to good nutrient removal. They do require space to be set aside so that storage of the WQCV can be achieved. Fact sheets in the USDCM provide additional information on each type of volume-based treatment.

1204.4.2 Flow-Based Facilities

Facilities that are designed based on an anticipated flow rate to be treated include grass swales, grass buffers, constructed wetland channels, infiltration trenches, and proprietary facilities. The USDCM provides design guidance on grass swales, grass buffers, and constructed wetland channels. Infiltration trenches and proprietary facilities are discussed below. Grass swales, grass buffers, and constructed wetland channels do not provide the degree of treatment that most of the flow-based methods provide, but they can provide a significant benefit to sites that will not accommodate a basin.

1204.4.3 Proprietary Treatment

Proprietary treatment facilities may be used to provide permanent water quality if they have been preapproved for use by Boulder County. Proprietary facilities are typically used only for very small peak flow rates, as they become cost ineffective at higher flow rates that are more suited to a water quality basin.

A proprietary treatment facility may be used in Boulder County if it has been certified by the Washington State Department of Ecology (WSDOE) Water Quality Program. WSDOE has a very thorough process by which to test and certify water treatment technologies. This process is known as the Technology Assessment Protocol–Ecology (TAPE) program. The TAPE program maintains an extensive list of stormwater treatment technologies approved through their processes. The list of products is categorized by the type of treatment provided and the level of testing that has been completed. Treatment categories include pretreatment, oil, enhanced, basic, phosphorus, and construction. The “basic” category of treatment will be used most often, as these products will meet the conditions of Boulder County’s MS4 permit for total suspended solids (TSS) removal. Products must meet the conditional or general use designation, indicating they have passed field performance tests. Products only meeting the pilot use level will not be accepted.

In the absence of any national program to test proprietary products, the WSDOE TAPE program provides a consistent and independent metric by which to evaluate proprietary systems. The list of approved designs is available online (<http://www.ecy.wa.gov/programs/wq/stormwater/newtech/technologies.html>) or can be found via an internet search for “WSDOE TAPE products.” Some commercial products that currently have the TAPE certification for conditional or general use for various categories of treatment include StormFilter, Vortechs, and Filterra.

The TAPE program has also approved the Media Filter Drain, which is an infiltration trench developed by the Washington State Department of Transportation (WSDOT) for use along highways. It has been very successful in removing metals such as zinc and copper from highway runoff, and is currently being used along some highways in Colorado.

The product ultimately chosen for water quality treatment should be evaluated based on the category it is certified for to ensure that it will meet specific site needs. Things to consider when choosing a proprietary product include the design flow rate to be treated, the anticipated peak flow rate through the system, and the target pollutants to be removed by the system.

1204.5 Maintenance Requirements

The performance of permanent water quality facilities is extremely sensitive to a lack of maintenance. If permanent water quality facilities are to be constructed, Boulder County requires an enforceable maintenance agreement to be in place prior to issuing any applicable local permits. The agreement must include the party responsible for maintaining the facility, inspection frequency, and proposed maintenance activities.

1205 REFERENCES

Urban Drainage and Flood Control District, 2016. *Urban Storm Drainage Criteria Manual: Volume 2 Structures, Storage, and Recreation*, prepared by the Urban Drainage and Flood Control District, Denver, CO.

Urban Drainage and Flood Control District, 2016. *Urban Storm Drainage Criteria Manual: Volume 3 Stormwater Quality*, prepared by the Urban Drainage and Flood Control District, Denver, CO.

Section 1300 Construction Water Quality Table of Contents

1301 INTRODUCTION	1300-1
1302 STORMWATER MANAGEMENT PLAN DEVELOPMENT	1300-1
1302.1 Work in Waterways	1300-2
1302.2 Construction Dewatering	1300-3
1302.3 Horizontal Directional Drilling	1300-3
1303 STORMWATER MANAGEMENT REPORT DEVELOPMENT	1300-4
1304 POTENTIAL POLLUTANT SOURCES	1300-4
1305 BEST MANAGEMENT PRACTICES	1300-5
1306 INSPECTION AND MAINTENANCE	1300-5
1307 FINAL STABILIZATION AND LONG-TERM MAINTENANCE	1300-5
1308 REFERENCES	1300-8

Appendices

Appendix A – Standard SWMP Plan Notes

Appendix B – SWMP Report Template for Local Development and Drainage Projects

Section 1300 Construction Water Quality

1301 INTRODUCTION

Construction typically results in land disturbance that can lead to erosion and sedimentation if action is not taken to prevent it. Erosion caused by construction activities can result in safety hazards, expensive maintenance problems, unsightly conditions, slope instability, ecosystem disruptions, and air and water quality problems. A commitment to control erosion and transport of sediment and other pollutants during design, construction, and maintenance is a priority to Boulder County.

This section discusses requirements and methodologies to limit erosion and the transport of sediment and other pollutants during construction, including site and material management practices. It applies to all stormwater generated from construction activity on any developed or undeveloped lands within the unincorporated county that eventually enters Boulder County's Municipal Separate Storm Sewer System (MS4), other storm drainage systems, or any waters of the state located within unincorporated Boulder County, unless specifically exempted. Discussion of features implemented to enhance water quality on a permanent basis, after construction is complete and final stabilization has been achieved, is included in Section 1200, Detention and Permanent Water Quality. The county should be contacted for additional information on county procedures regarding maintaining water quality during construction.

1302 STORMWATER MANAGEMENT PLAN DEVELOPMENT

Stormwater Management Plans (SWMPs) are required for all construction projects in Boulder County that require a stormwater quality permit from the county or a Colorado Discharge Permit System (CDPS) Construction Discharge Permit from the Colorado Department of Public Health and Environment (CDPHE), also known as a state stormwater discharge permit. Information on these permits is in Section 1400, Environmental and Regulatory Permitting. The SWMP consists of both a SWMP plan and report, both of which will be considered part of the construction documents so that construction contractors are bound to their contents, just as they would be to a construction plan set. This section describes the plan requirements, and Section 1303 describes the report requirements.

The design of construction best management practices (BMPs) for erosion and sediment control shall be consistent with the guidance in the CDOT *Erosion Control and Stormwater Quality Guide* (CDOT, 2006) or in the USDCM (UDFCD, 2016) and with the additional provisions and guidance in this MANUAL. In general, CDOT guidance will be used for linear projects such as roadways, and UDFCD guidance will be used for other projects. A combination of approaches is also acceptable. CDOT guidance can be found online at (<https://www.codot.gov/programs/environmental/water-quality/documents/erosion-storm-quality>) or via an internet search for "CDOT Erosion Control Guide."

Guidance from the UDFCD can be found online (<http://udfcd.org/volume-three>) or via an internet search for "UDFCD Drainage Criteria Manual Volume 3." These documents offer a considerable amount of guidance and background on construction BMPs that are not repeated in this section. Design engineers are encouraged to review these documents thoroughly to ensure that all appropriate considerations have been evaluated.

It should be noted that construction BMPs also include material management and site management BMPs, in addition to erosion and sediment control BMPs and that the SWMP documents need to reflect these BMPs as necessary. A key to effective stormwater management during construction is an understanding of how requirements can change over the course of a construction project. SWMPs may require multiple phases to be effective. SWMPs will require, at a minimum, initial BMPs that should be installed prior to any construction and final stabilization measures that will be completed as a last phase of the project.

Standard SWMP notes are included as an appendix to this section of the MANUAL and must be included on all plans, regardless of their assumed applicability before the start of construction. Boulder County has specific standards, in addition to what UDFCD and CDOT require, that shall be applied to all work in waterways, dewatering operations, and horizontal directional drilling. These requirements, if applicable, should be included on all SWMP documents.

Any work in or near a waterway will require a stormwater quality permit from the county. Application requirements for a stormwater quality permit are generally included in the CODE. Section 1400, Environmental and Regulatory Permitting, contains additional details.

1302.1 Work in Waterways

In addition to requiring a floodplain development permit from the county, construction in waterways requires a high standard of care in order to avoid and minimize damage to waterways, habitat, and aquatic life. The following list provides some general principles for working in a waterway:

1. Every effort shall be made to balance the protection of riparian habitat and protection of the stream bed/waterway itself.
2. No construction equipment shall be operated within the waterway or below the existing water surface unless specifically authorized by the stormwater quality permit issued by Boulder County, and any other applicable state or federal license or permit. Applicants are encouraged to create a dry work surface unless this would result in drying out a large section of the waterway and making it uninhabitable by aquatic life.
3. When work takes place within a channel, a temporary water diversion to bypass the work area is generally required to stabilize the work area and control erosion during construction. Diversions typically require an impervious liner to minimize seepage into the work area.
4. Dewatering operations will be required after the diversion is in place to manage seepage and establish a dry work surface. The water level at the work site should be below the subgrade an amount sufficient to provide a solid work surface that resists deformation during subgrade compaction.

5. Access must be planned and obtained to minimize entry into the waterway and disturbance to the channel. An engineered temporary stream crossing may be constructed only with county approval when an actively flowing waterway needs to be crossed regularly by construction vehicles. Design considerations are included in Volume 3 of the USDCM.
6. When possible, perform in-channel work between October 1 and March 31. While flood flows can happen at any time, this window historically provides a lower chance of high flows, excessive dewatering requirements, and failures during construction. Consider historical flow records for the subject waterway and other low-flow periods that may be created by diversions/water deliveries.
7. During cut and fill operations, avoid letting waste or excess material enter waterways or placing it on unstable areas. Excavated material should be carefully moved to areas needing fill or to a stockpile located outside the floodplain.

1302.2 Construction Dewatering

Dewatering is typically necessary and ongoing during construction that involves deep excavations, instream work, pumped surface diversions, or even open trench construction in some cases. Section 1302.1 contains additional information specific to instream dewatering. A discussion on permitting for discharge from construction dewatering is included in Section 1400, Environmental and Regulatory Permitting. Some general principles for dewatering that will minimize turbidity in the pumped water include:

1. For upland dewatering, use perimeter well points outside of the excavated area to draw down the water table rather than dewatering directly from the excavation
2. Place a submersible pump in a perforated bucket filled with gravel for short-term pumping
3. Construct a filtering sump pit for pumping groundwater below the bottom of the excavation for multiple-day operations
4. To avoid capturing the silt that can accumulate on the bottom of the sediment basin, use a flotation collar, or other flotation device, to pump from the surface
5. Use approved tanks or containers to provide retention time for sediment settling.

Additional guidance on construction dewatering is provided in Volume 3 of the USDCM.

1302.3 Horizontal Directional Drilling

Horizontal directional drilling or boring allows for the installation of underground utilities without digging trenches. This technique can provide more resilient and deeper installation and causes less surface impacts such as traffic delays and land disturbance. However, because of geologic conditions and the high pressures used during this process, there is a potential for drilling fluids to be released into the environment. The following practices will help prevent drilling fluid releases and minimize their impacts.

1. Evaluate the site for areas that have the potential to release fluids (dry and cracked soils or fractures and voids in geologic strata).

2. Establish containment areas for equipment, drilling fluids, and cutting refuge. Containment areas consist of some type of plastic sheathing formed with straw wattles to form a pit-like area, or an equivalent technique such as a compacted earthen berm.
3. Stage a vacuum truck, spill kits, and cleanup materials on site for immediate spill response before initiating any construction activities.
4. Examine drilling fluid pressures and return flows. Shut down drilling operations immediately if pressures and return flows indicate that drilling fluid is being released.
5. Assign staff to inspect the bore alignment and 100 feet up and downstream of the alignment, particularly when boring underneath waterways and diversion ditches, or when the bore alignment is in close proximity to storm drainage facilities. Shut down drilling operations immediately if a drilling fluid release is detected.
6. Contain all drilling fluids and cuttings for proper transportation and disposal at an approved facility.

1303 STORMWATER MANAGEMENT REPORT DEVELOPMENT

SWMP reports for county roadway projects should use the CDOT SWMP report template. Local development and drainage projects should use the SWMP report template included as an appendix to this section. SWMP reports will be considered part of the construction documents so that contractors are bound to their contents, as they would be to a construction plan set.

The SWMP report template for use on local development and drainage projects includes sections titled Introduction, Site Description, SWMP Plans, Potential Pollutant Sources, Best Management Practices, Final Stabilization and Long Term Maintenance, and Inspection and Maintenance. Inspection forms and spill report forms are also included. The template details what information should be in each section so that the permittee complies with the state stormwater discharge permit and Boulder County's stormwater quality permit.

1304 POTENTIAL POLLUTANT SOURCES

The main pollutant resulting from erosion is sediment. Sediments are typically inorganic silt, clay, or sand particles and in fine organic particulates. Less common pollutants include metals or nutrients, such as nitrogen or phosphorus, that may be disturbed during construction activities. These kinds of pollutants are often bound to soil or dust particles and transported off site along with the sediment. The mobility of pollutants that are bound to sediment is, therefore, dependent on the transport of the sediment particles themselves.

***Pollutants Commonly Discharged
from Construction Sites***

Sediment
Solid and sanitary wastes
Phosphorus (fertilizer)
Nitrogen (fertilizer)
Concrete truck washout
Construction chemicals
Construction debris/trash
Oil and grease
Pesticides

Other potential pollutants not associated with erosion are the chemicals that are used and stored at construction sites, including, but not limited to, pesticides, insecticides, petroleum products, solvents, disinfectants, and coolants.

1305 BEST MANAGEMENT PRACTICES

Construction BMPs should be selected, designed, installed, and maintained based on site-specific conditions before, during, and after construction. The number of stages that must be addressed in the SWMP depends on the type of construction activity. In general, the three stages of erosion and sediment control should include initial clearing and grading; utility, infrastructure and building construction; and final stabilization. BMPs appropriate to each phase of construction should be planned, installed, and monitored as construction progresses. It is important to understand whether the primary role of each BMP is erosion or sediment control. Effectively managed construction sites will provide a combination of BMPs that provide both functions. Table 1300-1 lists the various construction BMPs in the CDOT and UDFCD manuals that are available for use on projects in Boulder County. They are organized by the function they serve according to how CDOT groups them. CDOT and UDFCD have many similar BMPs, but some are unique to each organization and may not have a corresponding BMP in the other column. In addition, Faircloth Skimmers® are specifically approved by Boulder County for use during construction to modify the outlet of a sedimentation basin.

1306 INSPECTION AND MAINTENANCE

The construction site should be routinely checked for proper construction BMP installation and function in accordance with the SWMP plans and report. Any BMPs with loss of integrity, loss of function, or breaches shall be repaired immediately to reduce the potential for stormwater to transport sediment and other pollutants off site.

Good housekeeping practices such as proper waste handling, material storage, waste disposal, street sweeping, and effective vehicle tracking control reduces the potential for stormwater contamination. Documented inspections are required, but routine oversight of the site should include daily evaluation of BMPs to ensure that they are in place and operating effectively.

1307 FINAL STABILIZATION AND LONG-TERM MAINTENANCE

Final stabilization is achieved when all ground-disturbing activities at the site have been completed and the site has been revegetated. Revegetation is reached when a uniform perennial vegetative cover with a density of 70 percent of preconstruction levels has been established, or when an equivalent area of erosion control measures such as riprap have been employed. Preconstruction photographs shall be taken to aid the estimation of restored vegetative cover.

Table 1300-1. Construction Best Management Practices (Page 1 of 2)

CDOT	UDFCD
<i>Erosion Control BMPs</i>	
Seeding	Temporary and Permanent Seeding (TS/PS)
Mulching	Mulching (MU)
Mulch Tackifier	
Soil Binder	Soil Binders (SB)
Erosion Control Blankets	Erosion Control Blankets (ECB)
Turf Reinforcement Mats	Turf Reinforcement Mats (TRM)
Embankment Protector	Temporary Slope Drains (TSD)
Berm/Diversion	Temporary Diversion Channel (TDC)
Check Dams	Check Dams (CD)
Outlet Protection	Temporary Outlet Protection (TOP)
Temporary Drainage Swale	Earth Dikes and Drainage Swales (ED/DS)
Grading Techniques	Terracing (TER), Surface Roughening (SR)
	Compost Blanket and Filter Berm (CB)
	Rough Cut Street Control (RCS)
	Streambank Stabilization (SS)
<i>Sediment Control BMPs</i>	
Erosion Bale	Straw Bale Barrier (SBB)
Erosion Logs	Sediment Control Log (SCL)
Silt Fence	Silt Fence (SF)
Storm Drain Inlet Protection	Inlet Protection (IP) (multiple types)
Sediment Trap	Sediment Trap (ST)
Sediment Basin	Sediment Basin (SB)
Dewatering Structure	
Stabilized Construction Entrance	Vehicle Tracking Control (VTC) (multiple types)
Brush Barrier	Brush Barrier (BB)
Gravel Barrier	Rock Sock (RS)
Silt Barrier	
	Vegetated Buffers (VB)
	Chemical Treatment (CT)

Table 1300-1. Construction Best Management Practices (Page 2 of 2)

CDOT	UDFCD
<i>Materials Handling and Spill Prevention BMPs</i>	
Stockpile Management	Stockpile Management (SP)
Material Management	Good Housekeeping Practices (GH)
Material Use	Good Housekeeping Practices (GH)
Spill Prevention and Control	Good Housekeeping Practices (GH)
<i>Waste Management BMPs</i>	
Concrete Waste Management	Concrete Washout Area (CWA)
Solid Waste Management	Good Housekeeping Practices (GH)
Sanitary and Septic Waste Management	Good Housekeeping Practices (GH)
Liquid Waste Management	Good Housekeeping Practices (GH)
Hazardous Waste Management	Good Housekeeping Practices (GH)
Contaminated Waste Management	Good Housekeeping Practices (GH)
<i>General Pollution Prevention BMPs and Site Management</i>	
Dewatering Operations	Dewatering Operations (DW)
Temporary Stream Crossing	Temporary Stream Crossing (TSC) (multiple types)
Clear Water Diversion	Temporary Diversion Channel (TDC)
Nonstormwater Discharge Management	
Wind Erosion Control	Wind Erosion/Dust Control (DC)
Paving Operations	Paving and Grinding Operations (PGO)
Street Sweeping and Vacuuming	Street Sweeping and Vacuuming (SS)
Vehicle and Equipment Management	Good Housekeeping Practices (GH)
	Construction Fence (CF)
	Construction Phasing/Sequencing (CP)
	Protection of Existing Vegetation (PV)
	Stabilized Construction Roadway (SCR)
	Temporary Batch Plant (TBP)
	Stabilized Construction Roadway (SCR)
	Stabilized Staging Area (SSA)

When the site has been fully stabilized, and when construction BMPs are no longer needed and have been removed, the owner/operator shall submit a notice of termination to the county. Upon inspection and approval by the county, the owner/operator will notify the CDPHE that final stabilization is complete by submitting an Inactivation Notice.

1308 REFERENCES

Colorado Department of Transportation, 2002. *Erosion Control and Stormwater Quality Guide*, revised Chapter 5 EC 5&6 July 2014, prepared by the Colorado Department of Transportation, Denver, CO.

Urban Drainage and Flood Control District, 2016. *Urban Storm Drainage Criteria Manual: Volume 3 Stormwater Quality*, prepared by the Urban Drainage and Flood Control District, Denver, CO.

Section 1300 Appendix A – Standard SWMP Plan Notes

Best Management Practices

1. Contractor/permittee shall periodically inspect all installed BMPs, provide maintenance, and make repairs as necessary to prevent their failure.
2. Silt fence or an equivalent shall be placed as perimeter control on all construction activities that occur on land. Unless otherwise specified in the Contract Documents, or otherwise requested, remove perimeter controls within 30 days after the date of warranty performance of the work or in accordance with BMPs.
3. Vehicle tracking controls shall be used at all vehicle and equipment access points to the site to prevent sediment exiting the project site onto paved public roads. Access shall be provided only at locations approved by the Engineer. Vehicle tracking control locations shall be recorded on the SWMP site map.
4. All inlets and culverts shall be protected during onsite construction activities. Inlet protection locations shall be recorded on the SWMP site map.
5. Concrete wasted in designated dewatering areas shall be collected, removed from the project site, and disposed of properly. Wasted concrete also includes excess concrete removed from forms, spills, slop, and all other unused concrete that ends up on the ground.
6. The Contractor/permittee must maintain a spill kit on site when working around surface waters. If pollutants are spilled into any surface waters during the course of construction activities, the Contractor/permittee must notify the Owner's Representative or Engineer immediately.
7. All existing mature trees within the designated project area are to be fence protected in place at dripline unless otherwise directed by the Engineer. Prior to the initiation of work, the Engineer shall mark any trees and/or large shrubs to be removed as part of construction activities. Areas of tree removal shall be determined and marked in collaboration between the Contractor/permittee and the Engineer.
8. All excavation activities occurring within 10 feet of the dripline shall be performed by hand and if necessary roots shall be cleanly cut not torn or ripped. If exposed, tree roots shall be backfilled and watered on the same day of cutting and approved root stimulator shall be applied. Soils shall not be compacted within the dripline of mature trees unless otherwise approved by the Engineer.

Waste Management

1. The Contractor/permittee shall not burn, bury, or otherwise discharge construction or demolition waste on the site unless specified otherwise.
2. The Contractor/permittee shall provide a portable toilet and associated maintenance schedule for the construction area sufficient to accommodate the construction crew and all other authorized persons to be onsite during construction activities.

Hazardous Materials

1. The Contractor/permittee shall transport, use, and store hazardous materials in accordance with all regulatory requirements. Spilled hazardous materials, including hazardous liquid wastes, shall be removed from the site and the property restored to its pre-spill state in accordance with regulatory requirements.
2. The Contractor/permittee shall immediately report spills to the proper regulatory authority and shall immediately notify the Engineer.
3. Handling of construction fuels and lubricants:
 - A. The Contractor/permittee shall employ persons qualified to handle construction equipment fuels and lubricants.

Section 1300 Appendix A – Standard SWMP Plan Notes

- B. The Contractor/permittee shall refuel and service equipment away from floodplains of rivers, streams and other bodies of water. The Contractor/permittee shall ensure equipment that enters the water is free from external grease, oil, and mud.
- C. The Contractor/permittee shall prevent handling and fueling operations from contaminating the ground, surface water, and ground water. The Contractor/permittee shall use containment berms and an impermeable base course or other system to contain spilled fuel.

General Care of Water

Care of water shall include the design of all temporary care of water provisions including coffer dams, sumps, pumping systems, pipelines, channels, flumes, drains, and other protective and dewatering works to allow for work to be performed under dry conditions.

1. No construction equipment shall be operated below the existing water surface unless specifically authorized by the stormwater quality permit issued by Boulder County, and any other applicable local, state or federal license or permit.
2. The Contractor/permittee is responsible for all Care of Water including but not limited to designing, supplying, constructing, operating, and removing all care of water provision including coffer dams and sediment removal systems; designing, supplying, installing, maintaining, and removing protective works for winter operations of care of water systems.
3. The Contractor/permittee shall comply with all USACE 404 permit requirements including any special care requirements issued for this project.
4. When required the Contractor/permittee shall design temporary stream diversions to facilitate upstream fish passage. Instream velocities shall be limited to 7 ft/sec when this provision is required.
5. Care of water shall include provisions for handling groundwater, rainstorm runoff, snow, snowmelt, and ice that may enter the work area.
6. Protective works shall be designed by the Contractor/permittee as necessary to include enclosures, insulation, and heating systems to ensure that dewatering systems operate continuously and do not become frozen during cold weather.
7. The Contractor/permittee shall provide and maintain sediment ponds or other means, remove sediment from waters collected within active construction areas prior to allowing it to enter or return into the watercourse. Contractor/permittee shall dispose of sediments in a suitable off-site waste disposal facility.
8. The Contractor/permittee shall monitor water turbidity during construction activities and shall shut down works at times of excess turbidity in order to allow the water to clear prior to re-commencement of in-stream work.
9. Turbidity is expected during placement and removal of water control. If waters become noticeably turbid, Contractor/permittees should promptly halt operations to allow waters to clear prior to resuming operations. Furthermore, shutdowns for silty or turbid water may be specified by the Engineer or the Owner's Representative, at their discretion.
10. In the event of unscheduled construction activity that results in a visually conspicuous plume of sediment, Contractor/permittee shall immediately notify the Engineer and undertake mitigation actions necessary to comply with the specified clean water criteria.

Section 1300 Appendix A – Standard SWMP Plan Notes

Coffer Dams

1. The Contractor/permittee is responsible for the final layout, configuration, maintenance, and removal in their entirety of all coffer dams to be constructed within the project site.
2. The Contractor/permittee is responsible for the reclamation, to original or better condition, of all areas impacted by the construction of coffer dams. Reclamation may include but is not limited to the restoration of stable slopes typically equal to or less than 3H:1V, installation of approved erosion control fabric, and installation of an approved native seed mix.
3. Cofferdams located in the waterway shall be placed in a manner to prevent their erosion from normal or expected high flows. Furthermore, they should be placed to a sufficient elevation to prevent their overtopping during reasonably anticipated flood events that may compromise the design and performance of the cofferdam.
4. The use of riprap or other protection measures on the surfaces of the cofferdam, including the toe of cofferdam slopes exposed to high velocities, is required.
5. All temporary fills must be removed in their entirety following construction activities and affected areas graded to proposed conditions.
6. Cofferdams shall provide a bypass waterway that is armored and of the minimum dimensions shown in the typical water control channel detail.
7. Any coffer dam failures or other works efforts that cause a plume of turbid water to flow downstream shall be reported to the Engineer.

Heavy Equipment Operations and Maintenance

1. Equipment operated below the ordinary high water mark of the river channel, must be inspected and clean of fuel, lubricant leaks, and invasive aquatic species.
2. To minimize the spread of invasive species, all equipment shall be power-washed and free of weeds prior to its delivery to the project area. If equipment was used in another wet area within 10 days of initiating work, decontamination practices should be employed to minimize the spread of didymosphenia, New Zealand mud snails, whirling disease, zebra mussels, and other aquatic hitchhikers.
3. Equipment operating within or adjacent to any surface waters shall be free of fluid leaks. Biodegradable hydraulic fluids shall be utilized for all equipment operating in surface waters. The Contractor/permittee shall submit a list of equipment operating with certified non-toxic, biodegradable hydraulic fluids to the engineer prior to use. All fueling, oiling, or maintenance of equipment shall be performed in designated upland locations, with adequate BMPs to contain potential spills.

**Construction Phase
Stormwater Management Plan
(SWMP)**

for the

**[PROJECT NAME]
([PROJECT LOCATION])**

Prepared for:

BOULDER COUNTY

[PROJECT NUMBER]

[MONTH] [YEAR]

by:

**[DESIGN FIRM]
[CITY, STATE]**

[PROJECT NAME]
Stormwater Management Plan
For
BOULDER COUNTY, COLORADO

Project # [PROJECT NUMBER]

Index and Certification Page

Report Index

Section Number	<i>Section</i>	Number Of Pages
	Introduction	3
1	Site Description	1
2	Site Maps	1
3	Potential Pollutant Sources	1
4	Best Management Practices	3
5	Final Stabilization and Long Term Maintenance	1
6	Inspection and Maintenance	4
Appendix 1	Inspection Forms	4
Appendix 2	Spill Report Forms	2
Appendix 3	General Permit Application	5

Certifications(s)

INTRODUCTION

a) The Colorado Discharge Permit System (CDPS) General Permit and SWMP

For construction projects that require the disturbance of one acre or more, the U. S. Environmental Protection Agency (EPA) requires that the project owner apply for a stormwater permit under the National Pollutant Discharge Elimination System (NPDES) program. For the purposes of the NPDES program, construction activities are defined as clearing, excavating, grading, etc.

The EPA has delegated this permit program in the State of Colorado to the Colorado Department of Public Health and Environment (CDPHE). In compliance with the provisions of the Colorado Water Quality Control Act, (25-8-101 et seq., CRS, 1973 as amended), and the Federal Water Pollution Control Act, as amended (33 U.S.C. 1251 et seq.; the “Act”), and the regulations and standards adopted and promulgated thereunder, the CDPS General Permit (COR-030000) is issued. This permit is more specifically known as the Colorado Discharge Permit System (CDPS) general permit for Stormwater Discharges Associated with Construction Activities (state stormwater discharge permit). Projects issued a certificate of permit coverage under the state stormwater discharge permit are granted permission to discharge stormwater associated with construction activity into State waters. The state stormwater discharge permit issued for this project follows this page.

This document comprises the Stormwater Management Plan (SWMP) required by CDPHE, for construction projects that disturb one acre or greater of land in accordance with the state stormwater discharge permit. This document establishes a plan to manage the quality of stormwater runoff from construction activities associated with the [PROJECT NAME] in Boulder County, Colorado with the use of best management practices.

This SWMP meets all requirements of Sections B and C of Part I of COR-030000.

This plan is a guide to be used in the field to control and reduce erosion and the discharge of sediments and other pollutants. The plan should be changed, updated, and revised as necessary throughout the construction project. Best management practices should be moved, added, or redesigned as necessary to reduce and control erosion and the discharge of sediment and pollutants in accordance with good engineering, hydrologic and pollution control practices as specified in the Boulder County SDCM.

b) Project Owner and Operator

The project owner and operator is:

CONTRACTOR NAME

CONTRACTOR ADDRESS 1

CONTRACTOR ADDRESS 2

CONTRACTOR PHONE NUMBER

c) SWMP Signatory Requirements and Certification

The SWMP must clearly identify contractor(s) and/or subcontractor(s) responsible for implementation of the day-to-day activities necessary to complete project. Contractors and subcontractors must certify that they understand the requirements of the state stormwater discharge permit and the plan. Each contractor and/or subcontractor must complete one of the Contractor's Certification Forms, on page I-4 (Photocopy as necessary).

d) SWMP Administrator

The SWMP Administrator is responsible for the developing, implementing, maintaining, and revising all aspects of the SWMP. [Identify the SWMP Administrator. This can be a specific individual, position, or title]

e) Retention of Records

CONTRACTOR must maintain a copy of this SWMP on site at all times. CONTRACTOR shall retain copies of the SWMP and all reports required by the state stormwater discharge permit for a period of at least three years from the date that the project is completed.

f) Standard Permit Conditions

This section discusses state and federal penalties for non-compliance with the state stormwater discharge permit as well as termination of coverage of the permit. Further explanation of these issues is stated within each individual heading.

f.1) Duty to Comply with Permit Conditions

The EPA and CDPHE have substantial penalties for non-compliance with the state stormwater discharge permit. Any non-compliance constitutes a violation of the Act and is grounds for enforcement action including: permit termination; revocation, re-issuance, or modifications; or denial of permit renewal application. Individuals responsible for such violations are subject to criminal, civil and administrative penalties.

f.2) Final Stabilization and Termination of Coverage

Final stabilization is achieved when all ground surface disturbing activities at the site have been completed, and when a uniform perennial vegetative cover with a density of 70 percent or pre-disturbance levels has been established or equivalent erosion reduction measures (such as the use of riprap, gabions, or geotextiles) have been employed. Preconstruction photographs shall be taken to aid the estimation of restored vegetative cover. When the site has been fully stabilized, and when BMPs are no longer needed and have been removed, the CONTRACTOR can submit a notice of termination to Boulder County. Upon approval by Boulder County, the CONTRACTOR will notify CDPHE when final stabilization is complete by submitting an Inactivation Notice to CDPHE. The Inactivation Notice is located after the Contractor Certification forms in this document.

Section 1300 Appendix B – SWMP Report Template for Local Development and Drainage Projects

CONTRACTOR'S AND SUBCONTRACTOR'S CERTIFICATION		
<p>"I certify under penalty of law that I understand the terms and conditions of the general Colorado Discharge Permit System (CDPS) permit that authorizes stormwater discharges associated with industrial activity from the construction site identified as part of this certification."</p>		
Signature	For	Responsible For
<p>_____ (Name)</p> <p>_____ (Position)</p> <p>_____ (Signature)</p> <p>Email: _____ Date: _____</p>	<p>_____ (Company)</p> <p>_____ (Street / P.O. Box)</p> <p>_____ (City, State, Zip)</p> <p>Phone: _____</p>	<p>_____</p> <p>_____</p> <p>_____</p> <p>_____</p> <p>(Activity)</p>
<p>_____ (Name)</p> <p>_____ (Position)</p> <p>_____ (Signature)</p> <p>Email: _____ Date: _____</p>	<p>_____ (Company)</p> <p>_____ (Street / P.O. Box)</p> <p>_____ (City, State, Zip)</p> <p>Phone: _____</p>	<p>_____</p> <p>_____</p> <p>_____</p> <p>_____</p> <p>(Activity)</p>
<p>_____ (Name)</p> <p>_____ (Position)</p> <p>_____ (Signature)</p> <p>Email: _____ Date: _____</p>	<p>_____ (Company)</p> <p>_____ (Street / P.O. Box)</p> <p>_____ (City, State, Zip)</p> <p>Phone: _____</p>	<p>_____</p> <p>_____</p> <p>_____</p> <p>_____</p> <p>(Activity)</p>

1. SITE DESCRIPTION

a) Construction Activity Description

[Provide a description of the nature of the construction activity at the site and the project itself. Include a general description of the location and extents of the project, a summary of the construction to be completed, and the end product.]

b) Proposed Sequence of Major Activities

The sequencing of construction activity will be as follows:

1. [Describe the sequence of the construction activities and associated BMPs in a bulleted list or in a detailed schedule attached to this report.]

c) Area Estimates

The approximate area of the construction site is [TOTAL PROJECT AREA] acres. The area to undergo disturbance is approximately [EXPECTED AREA OF DISTURBANCE DUE TO CONSTRUCTION INCLUDING CLEARING EXCAVATION, GRADING, ETC] acres.

d) Soils

[Provide a summary of any existing data used in the development of construction plans or the SWMP that describe the soil and existing potential for soil erosion. This may include soils data, site soil investigations, etc.]

e) Existing Vegetation

[Provide a description of the existing vegetation at the site and an estimate of the percent vegetative ground cover. Pre-disturbance pictures should be taken so final stabilization can be validated as being achieved.]

f) Potential Pollution Sources

[Provide a precise location and description of all potential pollution sources] The Contractor will reduce the potential for contamination to stormwater runoff by implementing the best management practices contained in this document.

g) Non-Stormwater Discharges

[Provide a precise location and description of any anticipated allowable sources of non-stormwater discharge at the site (e.g. uncontaminated springs, irrigation return flow, construction dewatering, etc.)]

h) Receiving Waters

[Provide a general description of drainage at the site. Provide the name of receiving water(s) and the size, type and location of any outfalls. If the stormwater discharge is to a municipal separate storm sewer system, include the name, location of discharge, and the ultimate receiving water(s).]

2. SWMP PLANS

[Provide a brief description of attached maps for the SWMP. The map(s) must include

- 1) Construction site boundaries
- 2) All areas of ground surface disturbance
- 3) Areas of cut and fill
- 4) Areas used for storage of building materials, equipment, soil, or waste
- 5) Locations of dedicated batch plants
- 6) Locations of all structural BMPs
- 7) Locations of all non-structural BMPs as applicable
- 8) Delineations of all floodplains and floodways
- 8) Locations of springs, streams, wetlands and other surface waters

SWMP plans shall include construction details for each construction BMP that is specified on the SWMP plan.]

3. POTENTIAL POLLUTANT SOURCES

The following sources and activities have been identified as having the potential to contribute pollutants to stormwater discharges. These sources will be controlled through BMP selection and implementation as described in Section 4 Best Management Practices of this chapter.

[Identify and describe sources determined to have the potential to contribute pollutants to stormwater discharges. As required under Section I.B.3.d of the state stormwater discharge permit, at a minimum, each of the following sources/activities must be evaluated for the potential to contribute pollutants to stormwater discharges:

- 1) All disturbed and stored soils
- 2) Vehicle tracking of sediments
- 3) Management of contaminated soils
- 4) Loading and unloading operations
- 5) Outdoor storage activities (building materials, fertilizers, chemicals, etc.)
- 6) Vehicle and equipment maintenance and fueling
- 7) Significant dust or particulate generating processes
- 8) Routine maintenance activities using fertilizers, pesticides, detergents, fuels, solvents, oils, etc.
- 9) On-site waste management practices (waste piles, liquid wastes, dumpsters, etc.)
- 10) Concrete truck/equipment washing, including the concrete truck chute, fixtures and equipment
- 11) Dedicated asphalt and concrete batch plants
- 12) Non-industrial waste sources such as worker trash and portable toilets; and
- 13) Other areas or procedures where potential spills can occur]

4. BEST MANAGEMENT PRACTICES

a) Erosion and Sediment Control Devices

Soil erosion and sediment controls are measures that are used to reduce the amount of soil particles that are carried off a land area and deposited in the receiving water. This section provides a general description of the most appropriate measures planned for this project. The contractor or whoever the owner/operator has chosen as the responsible party for the erosion and sediment control devices must amend this SWMP and adjust the locations and types of best management practices as needed depending on the daily construction activities so that erosion, sediment, and other pollutants are controlled in accordance with good engineering, hydrologic and pollution control practices as specified in the Boulder County SDCM.

All applicable soil erosion and sediment control measures shall be implemented in accordance with the guidelines contained herein prior to commencement of field construction activities at each location. Measures shall be maintained during and after the construction activity until final stabilization is accomplished. Upon successful revegetation of the disturbed area, all temporary soil erosion and sediment control measures will be removed by the contractor.

a.1) Structural Practices

Various structural erosion and sediment control devices will be used on site. This section gives a description of each. [Provide a description and location of all structural erosion and sediment control practices that will be implemented with this project in the following subsections or in a general paragraph where appropriate. Practices may include, but are not limited to straw bales, wattles/sediment control logs, silt fences, earth dikes, drainage swales, sediment traps, subsurface drains, pipe slope drains, inlet protection, outlet protection, gabions, and temporary or permanent sediment basins.] The locations of these measures are shown on the SWMP Plans.

a.1.1) [NAME OF PRACTICE]

[Provide a description and location of the structural erosion and sediment control practice. Description should include the installation and implementation of the BMP. Insert additional sections as needed.]

a.2) Non-Structural Practices

Various non-structural erosion and sediment control devices will be used on site. This section gives a description of each. [Provide a description and location of all non-structural erosion and sediment control practices that will be implemented with this project in the following subsections or in a general paragraph where appropriate. Practices may include, but are not limited to temporary vegetation, permanent vegetation, mulching, geotextiles, sod stabilization, slope roughening, vegetative buffer strips, protection of trees, and preservation of mature vegetation.]

a.2.1) [NAME OF PRACTICE]

[Provide a description and location of the non-structural erosion and sediment control practice. Description should include the interim and permanent stabilization practices and site-specific scheduling for implementation. Insert additional sections as needed.]

b) Phased BMP Implementation

[Provide a description of the relationship between phases of construction, and the implementation of structural and non-structural stormwater management controls. Identify stormwater management controls to be implemented during the project phases. These controls can include, but are not limited to clearing and grubbing; road construction; utility and infrastructure installation; vertical construction; final grading; and final stabilization. Phased implementation should be based on the proposed sequence of major activities included in Section 1.b.]

c) Materials Handling and Spill Prevention

[Describe and locate all practices implemented at the site to minimize impacts from procedures or significant materials (defined in Part I.E. of the state stormwater discharge permit) that could contribute pollutants to runoff. Such procedures or significant materials could include exposed storage of building materials, paints and solvents, fertilizers or chemicals, waste material, and equipment maintenance or fueling procedures. Identify any areas or procedures where potential spills can occur and response procedures.]

c.2.1) [NAME OF PRACTICE]

[Provide a description and location of the practice. Insert additional sections as needed.]

d) Dedicated Concrete or Asphalt Batch Plants

[Provide a description and location of all practices implemented at the site to control stormwater pollution from dedicated concrete batch plants or dedicated asphalt plants included in this certification.]

d.2.1) [NAME OF PRACTICE]

[Provide a description and location of the practice. Insert additional sections as needed.]

e) Vehicle Tracking Control

[Provide a description and location of all practices implemented at the site to control potential sediment discharges from vehicle tracking. Practices can include minimizing site access, street sweeping or scraping, tracking pads, graveled parking areas, requiring that vehicles stay on paved areas on-site, wash racks, contractor education, and/or sediment control BMPs, etc.]

e.2.1) [NAME OF PRACTICE]

[Provide a description and location of the practice. Insert additional sections as needed.]

f) Waste Management and Disposal

[Provide a description and location of the practices implemented to control stormwater pollution from all construction site wastes (liquid and solid), including concrete washout activities. Describe and locate the practices to be used that will ensure that wash water from concrete activities is never discharged from the site as surface runoff or to surface waters as this is an illegal practice.]

f.2.1) [NAME OF PRACTICE]

[Provide a description and location of the practice. Insert additional sections as needed.]

g) Groundwater and Stormwater Dewatering

[Provide a description and location of the practices implemented to control stormwater pollution from the dewatering of *uncontaminated* groundwater or stormwater from excavations, wells, etc. to the ground. For any construction dewatering of groundwater not authorized under a separate CDPS dewatering permit, the SWMP shall clearly describe and locate the practices to be used that will ensure that no groundwater from construction dewatering is discharged from the site as surface runoff or to surface waters.]

g.2.1) [NAME OF PRACTICE]

[Provide a description and location of the practice. Insert additional sections as needed.]

5. FINAL STABILIZATION AND LONGTERM MANAGEMENT

a) Final Stabilization

Final stabilization consists of the final planting of perennial vegetation in all disturbed, unvegetated areas affected by construction that are not covered with a hardscape such as rock, asphalt, or concrete.

The temporary erosion control devices shall be removed upon project completion by the contractor. The owner/operator is responsible for final site stabilization (with perennial vegetative species) within 30 days of project completion or as otherwise specified by the contract documents. Following the completion of construction and planting activities, the construction inspector shall conduct periodic site reviews to ensure that vegetation establishment is satisfactory. If vegetative cover is not adequate, special steps to correct problems shall be implemented such as over-seeding, mulching, sodding, or the use of erosion control blankets.

Final stabilization is achieved when all soil-disturbing activities at the site have been completed, and when a uniform perennial vegetative cover with a density of 70 percent has been established or equivalent measures (such as the use of riprap, gabions, or geotextiles) have been employed. When the site has been fully stabilized and all stormwater discharges from construction activities that are authorized by this state stormwater discharge permit are eliminated, the project is then terminated. The Contractor will notify CDPHE and Boulder County when final stabilization is complete by submitting an Inactivation Notice. The Inactivation Notice is located after the Contractor Certification forms at the end of the Introduction.

[Provide a description of all practices to be used to achieve final stabilization of all disturbed areas at the site. Final stabilization practices must include, as appropriate, seed mix selection and application methods, soil preparation and amendments, soil stabilization practices, and appropriate sediment control BMPS as needed until final stabilization is achieved.]

a.1) [NAME OF PRACTICE]

[Provide a description and location of the practice. Insert additional sections as needed.]

b) Long-Term Practices

The following practices will be installed as permanent controls or controls that do not need to be removed after construction is terminated and the site is fully stabilized with vegetation. These practices will be used to control pollutants in stormwater discharges that will occur after construction operations have been completed.

b.1) [NAME OF PRACTICE]

[Provide a description of the practice that will be used to control pollutants in stormwater discharges that will occur after construction operations have been completed at the site. Insert additional sections as needed.]

6. INSPECTION AND MAINTENANCE

a) Maintenance and Inspection

All erosion and sediment control devices shall be installed pursuant to the specifications and the construction details. They shall be maintained so that they remain effective at all times. Sediment will be removed from behind sediment controls when it reaches one-half the height of the control.

A thorough inspection of the stormwater management system shall be performed at least once every 14 days and within 24 hours after the end of any precipitation or snowmelt event that causes surface erosion. Any reduction in inspections shall comply with the requirements of section I.6.a of the state stormwater discharge permit and shall be documented in the inspection record. During inspection, the construction inspector shall complete the inspection forms found in Appendix 1. These sheets should be copied and used as necessary. Ineffective temporary erosion control measures shall be repaired as soon as possible after identification. The construction inspector shall immediately install additional temporary erosion control devices in any area deemed in need of protection.

If inspection results indicate a need for revision to the SWMP, the plan shall be revised and implemented, as appropriate, within seven calendar days following the inspection. All modifications should be noted on the Record of Revisions sheet found in Appendix 1. The inspection reports shall identify any incidents of non-compliance with the state stormwater discharge permit.

b) Material Management Practices

Properly managing hazardous, toxic, or petroleum products on the construction site will greatly reduce the potential for stormwater pollution by these materials. Good housekeeping along with proper use and storage of these construction materials form the basis for proper hazardous material management.[Provide a description of all maintenance procedures implemented at the site to maintain all erosion and sediment control practices and other protective practices identified in the SWMP.]

b.1) Good Housekeeping

The proper use of materials and equipment along with the use of good housekeeping practices greatly reduces the potential for contaminating stormwater runoff. The following is a list of good housekeeping practices to be used during the construction project:

- Storage of hazardous materials, chemicals, fuels, and oils, and fueling of construction equipment, shall not be performed within 150 feet of any stream bank, wetland, water supply well, spring, or other water body.
- An effort will be made to store only enough product required to do the job.
- Materials stored on the site will be stored in a neat, orderly manner in their appropriate containers and, if possible, under a roof or other enclosure.

- Products will be kept in their original containers with the original manufacturer's label.
- Substances will not be mixed with one another unless recommended by the manufacturer.
- Whenever possible, all of the product will be used up before disposing of the container.
- Manufacturer's recommendations for proper use and disposal of a product will be followed.
- If surplus product must be disposed of, manufacturers' or local and state recommended methods for proper disposal will be followed.

b.2) Product-Specific Practices

Due to the chemical makeup of specific products, certain handling and storage procedures are required to promote the safety of handlers and prevent the possibility of pollution. Care shall be taken to follow all directions and warnings for products used on the site. All pertinent information can be found on the Material Safety Data Sheets (MSDS) for each product. The MSDS sheets should be located with each product container it represents. Several product-specific practices are listed in the following sections. [delete or add subsections as applicable]

b.2.1) Petroleum Products

On-site vehicles will be monitored for leaks and receive regular maintenance to reduce the chance of leakage. Petroleum products will be stored in tightly sealed containers that are clearly labeled. Preferably, the containers will be stored in a covered truck or trailer that provides secondary containment for the products.

Bulk storage tanks having a capacity of greater than 55 gallons will be provided with secondary containment. Containment can be provided by a temporary earthen berm or other means. After each rainfall, the contractor shall inspect the contents of the secondary containment area. If there is no visible sheen on the collected water, it can be pumped to the ground in a manner that does not cause scouring. If a sheen is present, it must be cleaned up prior to discharging the water.

Bulk fuel or lubricating oil dispensers shall have a valve that must be held open to allow the flow of fuel or oil. During fueling operations, the contractor shall have personnel present to detect and contain spills.

b.2.2) Fertilizers

Fertilizers used to stimulate vegetation growth will be used in minimal amounts recommended by the manufacturer with the approval of Boulder County Parks and Open Space if the project is subject to their approval. Once applied, the fertilizer will be worked into the soil to limit exposure to stormwater.

c) Spill Control and Cleanup

In addition to the material management practices discussed previously, the following spill control and cleanup practices will be followed to prevent stormwater pollution in the event of a spill:

- Spills will be contained and cleaned up immediately after discovery.
- Manufacturer's methods for spill cleanup of a material will be followed as described on the material's MSDS.
- Materials and equipment required for cleanup procedures will be kept readily available on the site, either at an equipment storage area or on contractor's trucks. Equipment to be kept on the site will include but not be limited to brooms, dust pans, shovels, granular absorbents, sand, saw dust, absorbent pads and booms, plastic and metal trash containers, gloves, and goggles.
- Personnel on the site will be made aware of cleanup procedures and the location of spill cleanup equipment.
- Toxic, hazardous, or petroleum product spills will be documented to the appropriate federal, state, and local agencies.
- Spills will be documented and a record of the spills will be kept with this SWMP.

If a spill occurs that is reportable to the federal, state, or local agencies, the contractor is responsible for making the notifications.

The federal reportable spill quantity for petroleum products is defined in 40 CFR 110 and is any oil spill that:

- Violates applicable water quality standards,
- Causes a film or sheen upon or discoloration of the water surface or adjoining shoreline, or
- Causes a sludge or emulsion to be deposited beneath the surface of the water or adjoining shorelines.

The federal reportable spill quantities for hazardous materials are listed in 40 CFR, Part 302.4 in the table entitled *List of Hazardous Substances and Reportable Quantities*. Ethylene glycol (antifreeze) should be included in this list and has a reportable quantity of one pound. A procedure for determining a reportable spill is included in Appendix 2 along with a copy of the Spill Report Form to be filled out in case of a spill.

A release of any chemical, oil, petroleum product, sewage, etc., which may enter waters of the State of Colorado (which include surface water, ground water and dry gullies or storm sewers leading to surface water) must be reported to CDPHE immediately (25-8-601 CRS). Written notification to CDPHE must follow within five (5) days (5 CCR 1002-61, Section 61.8(5)(d)). Any accidental discharge to the sanitary sewer system must be reported immediately to the local sewer authority and the affected wastewater treatment plant.

Section 1300 Appendix B – SWMP Report Template for Local Development and Drainage Projects

Releases of petroleum products and certain hazardous substances listed under the Federal Clean Water Act (40 CFR Part 116) must be reported to the National Response Center as well as to CDPHE as required under the Clean Water Act and the Oil Pollution Act.

If a spill is reportable, the Contractor's superintendent will notify the Owner and the following authorities:

Federal:	National Response Center - 1-800-424-8802
State:	Colorado Department of Public Health and Environment Toll-Free 24-hour Environmental Emergency Spill Reporting Line 1-877-518-5608
Local:	Local Emergency Planning Committee (OEM) (303) 273-1622 Division of Oil & Public Safety-Storage Tanks (303) 318-8547 Oil and Gas Conservation Commission (303) 894-2100

If a reportable release occurs, a modification to the SWMP must be made within 14 days. The modification shall include:

- a description of the release;
- the date of the release;
- an explanation of why the spill happened;
- a description of procedures to prevent future spills and/or releases from happening; and
- a description of response procedures if a spill or release would occur again and within 14 days of the release.

A written description of the release must be submitted to the permitting authority that includes:

- a description of the release, including the type of material and an estimated amount of spill;
- the date of the release;
- an explanation of why the spill happened;
- a description of the steps taken to prevent and control future releases.

These modifications to the SWMP must be made by the contractor and will be documented on the Spill Report form in Appendix 2. In addition, the Spill Report form must be certified at the bottom.

**SWMP REPORT APPENDIX 1
INSPECTION FORMS**

Section 1300 Appendix B – SWMP Report Template for Local Development and Drainage Projects

Boulder County, Colorado
[Project Name]
([Project Location])
SWMP INSPECTION REPORT

Project: [Project Name] _____ Drawing No.: _____

Construction Engineer: _____ Contractor: _____

Inspector: _____ Title: _____ Date: _____

Site Conditions: _____

Type of Inspection: _____ WEEKLY _____ BIWEEKLY _____ PRECIP EVENT _____

OTHER

If deviated from minimum schedule explain why: _____

Control Measure [Insert applicable control measures]	Location of Control Measure	In Conformance with Design Standards	Corrective Action Required (see page 2)
[Control Measure]		YES / NO	YES / NO
[Control Measure]		YES / NO	YES / NO
[Control Measure]		YES / NO	YES / NO
[Control Measure]		YES / NO	YES / NO
[Control Measure]		YES / NO	YES / NO
[Control Measure]		YES / NO	YES / NO
[Control Measure]		YES / NO	YES / NO
[Control Measure]		YES / NO	YES / NO
[Control Measure]		YES / NO	YES / NO
[Control Measure]		YES / NO	YES / NO
[Control Measure]		YES / NO	YES / NO
[Control Measure]		YES / NO	YES / NO

LIST LOCATION OF DISCHARGES FROM THE SITE (Sediment or other pollutants):

LIST LOCATION WHERE ADDITIONAL BMPS ARE NEEDED:

LIST LOCATION WHERE BMP MAINTENANCE IS NEEDED:

VIOLATIONS NOTED: (Explain each "NO circled above)

RECOMMENDED REMEDIAL ACTIONS:

**SWMP REPORT APPENDIX 2
SPILL REPORT FORMS**

Boulder County, Colorado
[Project Name]
([Project Location])
Stormwater Management Plan
Spill Report Form

Spill Reported By: _____
Name

Phone Number

Company: _____

Date Reported: _____

Time:

Date of Spill: _____

Time:

Name of Facility:

Legal Description: _____ QTR, SEC _____, TWP _____, Range _____

County Adams

Describe Spill Location and Events Leading to Spill:

Material Spilled:

Source of Spill:

Amount Spilled (Gallons or Pounds):

Amount Spilled to Waterway (Gallons or Pounds):

Nearest Municipality:

Section 1300 Appendix B – SWMP Report Template for Local Development and Drainage Projects

Containment or Cleanup Action:

List Environmental Damage (fish kill, etc.):

List Injuries or Personal Contamination:

Date and Time Cleanup Completed or Terminated:

If Cleanup Delayed, Nature and Duration of Delay:

Description of Materials Contaminated:

Approximate Depth of Soil Excavation:

Action To Be Taken to Prevent Future Spills:

Agencies Notified:

Local: _____ Date: _____

State: _____ Date: _____

Fed: _____ Date: _____

Signed: _____

Contractor Superintendent or
Environmental Inspector

**SWMP REPORT APPENDIX 3
GENERAL PERMIT APPLICATION**

Section 1400 Environmental and Regulatory Permitting

Table of Contents

1401 INTRODUCTION	1400-1
1402 CLEAN WATER ACT 404 PERMIT.....	1400-2
1403 ENDANGERED SPECIES ACT.....	1400-2
1404 NATIONAL ENVIRONMENTAL POLICY ACT (NEPA).....	1400-3
1404.1 Categorical Exclusion (CE)	1400-3
1404.2 Environmental Assessment.....	1400-3
1404.3 Environmental Impact Statement.....	1400-4
1405 STATE WATER QUALITY CLEARANCES.....	1400-4
1405.1 Water Quality Certification	1400-4
1405.2 CDPS Construction Stormwater Permit	1400-5
1405.3 CDPS Construction Dewatering Permit.....	1400-5
1405.4 CDPS Industrial Stormwater Permit.....	1400-5
1406 FLOODPLAIN REGULATIONS AND PERMITTING.....	1400-5
1406.1 Boulder County Floodplain Regulations.....	1400-6
1406.2 Colorado Water Conservation Board Floodplain Regulations	1400-6
1406.3 Federal Emergency Management Agency Floodplain Requirements.....	1400-6
1407 COUNTY PERMITTING	1400-6
1407.1 Boulder County Stormwater Quality Permit.....	1400-7
1407.2 Additional Boulder County Permits	1400-7
1408 MISCELLANEOUS PERMITTING CONSIDERATIONS.....	1400-8
1409 REFERENCES.....	1400-8

Section 1400 Environmental and Regulatory Permitting

1401 INTRODUCTION

Regulatory compliance and environmental permitting need to be considered for every project. Permits are required for most construction projects, regardless of whether a project is a large or small stream restoration project, or a public or private infrastructure project. This section lists the permits that may be required and the regulations that may apply when doing work within Boulder County. Table 1400-1 lists the most common potential permits, issuing agencies, and governing policies for projects in the county. This list may not be all-inclusive as a project may require an environmental permit that is not listed. It is important to note that the applicability and requirements of each permit can change over time. The text of this MANUAL may become outdated as governing policies are amended. Permitting professionals, developers, and design engineers are encouraged to consult the most current guidance available at the onset of each project to ensure compliance.

Table 1400-1. Summary of Environmental Permits

Permit Name	Issuing Agency	Governing Policy
404 Permit	USACE	Clean Water Act
ESA "No Effect" Determination	USFWS	Endangered Species Act
Categorical Exclusion	EPA	National Environmental Policy Act
Environmental Assessment	EPA	National Environmental Policy Act
Environmental Impact Statement	EPA	National Environmental Policy Act
401 Water Quality Certification	CDPHE	State Water Quality Permit
CDPS Construction Stormwater	CDPHE	State Stormwater Permit
CDPS Construction Dewatering	CDPHE	State Stormwater Permit
CDPS Industrial Stormwater	CDPHE	State Stormwater Permit
Stormwater Quality Permit	Boulder County	Local Permitting
Access, Building, Construction, Grading, Floodplain	Boulder County	Local Permitting

Detailed analysis of each project's characteristics is required to determine specific permit requirements and necessary compliance measures. Upfront coordination with each permitting agency is recommended to understand all current permit requirements and approval schedules as approvals can often take several months, depending on the permit. It is also important to note that incorporating ecological design components into a project may potentially minimize the number of environmental permits required or expedite the approval process.

1402 CLEAN WATER ACT 404 PERMIT

The Clean Water Act (CWA) provides the basic structure for regulating discharges of pollutants into waters of the United States and regulating quality standards for surface water. Section 404 of the CWA establishes a permitting process that regulates the discharge of dredged or fill materials into waters of the U.S., including rivers, lakes, streams, and most wetlands. Regulated activities include fills for development, water resource projects including dams and levees, channel restoration or improvements, infrastructure development, and conversion of wetlands to uplands for farming and forestry.

An individual permit is required for potentially significant impacts. Individual permits are reviewed by the U.S. Army Corps of Engineers (USACE), which evaluates applications under a public interest review, as well as the environmental criteria set forth in the CWA. For most discharges that will have only minimal adverse effects, a general permit may be suitable. General permits are issued on a nationwide, regional, or state basis for particular categories of activities. The general permit process eliminates individual review and allows certain activities to proceed with little or no delay, provided the conditions of the general permit are met. For example, minor road activities, utility line backfill, and bedding are all activities that can all be considered for a general permit.

When landowners apply for an individual 404 Permit, they must show that they have taken steps to minimize wetland and stream impacts, provide compensation for any unavoidable impacts, and engage in activities to restore or create wetlands and streams. Boulder County requires a 404 Permit, or a letter from the USACE stating that a 404 Permit is not needed, before a Floodplain Development Permit will be issued for work within the bed and banks of a waterway. Individual permits for projects in Boulder County are reviewed and approved by the Denver Regulatory Office of the Omaha District of the USACE. Additional details can be found via an internet search for "Section 404 Permit Program" or online (<http://www.epa.gov/cwa-404/section-404-permit-program>).

1403 ENDANGERED SPECIES ACT

The purpose of the Endangered Species Act (ESA) is to conserve threatened and endangered species and the ecosystems they depend on. It is administered by the U.S. Fish and Wildlife Service for terrestrial and freshwater organisms. ESA compliance was recently added to the list of documentation that must be provided to the Federal Emergency Management Agency (FEMA) before they will issue a Conditional Letter of Map Revision (CLOMR).

ESA compliance begins with one of three possible effect determinations: (1) no effect; (2) may affect, but is not likely to adversely affect; (3) and may affect, and is likely to adversely affect. The Colorado Ecological Service Field Office can be of service in completing an effect determination. If a no effect determination is made, ESA compliance is achieved. If a CLOMR application is being submitted as part of the project, documentation of the no effect determination must be submitted with the application. If any other determination is made, additional action may be required, such as completing a biological

assessment. The Colorado Ecological Service Field Office can provide guidance on additional steps that will be required.

1404 NATIONAL ENVIRONMENTAL POLICY ACT (NEPA)

The National Environmental Policy Act (NEPA) was signed into law on January 1, 1970. It establishes national policy and goals for the protection, maintenance, and enhancement of the environment. It also provides a process for implementing these goals within federal agencies. The NEPA process consists of an evaluation of the environmental effects of any federal undertaking, including its alternatives. A NEPA analysis is required if any federal permit is issued, including a 404 Individual Permit (general permits do not trigger the NEPA process), or if any federal funds are used to pay for any part of a project. There are three levels of analysis: categorical exclusion; preparation of an Environmental Assessment/Finding of No Significant Impact (EA/FONSI); and preparation of an environmental impact statement (EIS).

1404.1 Categorical Exclusion (CE)

A project or action may be categorically excluded from requiring a detailed environmental analysis if it has certain characteristics that a federal agency has previously determined will cause no significant environmental impact. A number of agencies have developed lists of actions that are typically categorically excluded from requiring any environmental evaluation under NEPA regulations.

Details on categorical exclusions can be found via an internet search for "NEPA Categorical Exclusion," followed by an agency name (e.g., USACE). Guidance on categorical exclusions that are identified by the Federal Highway Administration (FHWA) can be found online (<https://www.environment.fhwa.dot.gov/projdev/docuce.asp>)

1404.2 Environmental Assessment

If a categorical exclusion does not apply, a written EA must be prepared to determine if a federal undertaking would significantly affect the environment. If it will not, the agency issues a FONSI. The FONSI may address measures an agency will take to mitigate potentially significant impacts.

When the significance of impacts of a project proposal is uncertain, an EA is prepared to assist in making this determination. If it is found that significant impacts will result, the preparation of the EIS should commence immediately.

A concise public document shall be prepared that addresses the following:

1. Briefly provide sufficient evidence and analysis for determining whether to prepare an environmental impact statement or a finding of no significant impact.
2. Aid an agency's compliance with NEPA when no environmental impact statement is necessary.
3. Facilitate preparation of a statement when one is necessary.

The EA shall include a brief discussion of the need for the proposed project, alternatives to the proposed project, environmental impacts of the proposed project and alternatives, and a listing of agencies and persons consulted. EAs do not need to be circulated, but they must be made available to the public

through notices of availability in local, state, or regional clearinghouses, newspapers, and other means. A public hearing may or may not be required. A 30-day review period is required but may be reduced in rare circumstances.

After public comments are received and considered, a determination of the significance of the impacts is made. If the project would result in significant impacts, an EIS must be prepared. However, if it is evident that there are no significant impacts associated with the project, a FONSI may be prepared.

Details on the EA can be found via an internet search of "NEPA Environmental Assessment" or online (<https://www.environment.fhwa.dot.gov/projdev/docuea.asp>).

1404.3 Environmental Impact Statement

An EIS is a more detailed evaluation of a proposed project and its alternatives. If the EA determines that the environmental consequences of a proposed federal undertaking may be significant, an EIS is required. A federal agency may also choose to prepare an EIS without first preparing an EA if it anticipates that a project may have significant environmental impact or if it is environmentally controversial. The public, other federal agencies, and outside parties may provide input during the preparation of an EIS and then comment on the draft EIS when it is completed.

After an EIS is prepared, a federal agency will prepare a public record of its decision that addresses how the EIS findings, including consideration of alternatives, were incorporated into the decision-making process. An EIS is completed in the following ordered steps: Notice of Intent (NOI), draft EIS, final EIS, and record of decision (ROD).

As an example, the EIS documentation process adopted by the FHWA can be found via an internet search for "FHWA NEPA EIS" or online (<https://www.environment.fhwa.dot.gov/projdev/docueis.asp>).

1405 STATE WATER QUALITY CLEARANCES

The Water Quality Control Division (WQCD) of the CDPHE reviews applications and issues Water Quality Certifications and other water quality permits, including the State Water Quality Certification, the Colorado Discharge Permit System (CDPS) Construction Stormwater Permit, the CDPS Construction Dewatering Permit, and the CDPS Industrial Stormwater Permit.

1405.1 Water Quality Certification

The WQCD reviews applications and issues the 401 Water Quality Certification for projects or actions that are applicable to the provisions of the Colorado 401 Certification Regulation (No. 82: 5 CCR 1002-82). A 401 certification is required when any federal license or permit, such as an individual 404 permit, is issued to construct or operate a facility that may result in any fill or discharge into navigable waters of the U.S.

Details of the application process and the requirements of the application can be found via an internet search for “CDPHE 401 Water Quality Certification” or online (<https://www.colorado.gov/pacific/cdphe/wq-401-water-quality-certification>).

1405.2 CDPS Construction Stormwater Permit

The WQCD reviews applications for and issues the Construction Stormwater Permit. This permit is for the regulation of stormwater runoff from construction activities and specific allowable non-stormwater discharges that are identified in the permit. Construction activities include all activities that disturb the ground surface, including, but not limited to, clearing, grading, excavation, demolition, installation of new or improved haul and access roads, staging areas, stockpiling of fill materials, and borrow areas.

Process and application details can be found via an internet search for “CDPHE Construction General Permits” or online (<https://www.colorado.gov/pacific/cdphe/wq-construction-general-permits>).

1405.3 CDPS Construction Dewatering Permit

The WQCD reviews applications for and issues the Construction Dewatering Permit. This permit authorizes the discharge of construction dewatering source water throughout Colorado to waters of the state. Construction dewatering source water includes surface water or stormwater that has mixed with groundwater and been exposed to construction activities. This permit only authorizes discharges for which the source water is drawn from specific areas identified in the application.

Process and application details can be found via an internet search for “CDPHE Construction General Permits” or online (<https://www.colorado.gov/pacific/cdphe/wq-construction-general-permits>).

1405.4 CDPS Industrial Stormwater Permit

The WQCD reviews applications for and issues the Industrial Stormwater Permit. This permit is for individual discharges of industrial process water to surface water, groundwater, or stormwater facilities. Discharges to groundwater may occur via impoundments, whether or not they discharge to surface water, land application, and septic systems whose design capacity is greater than 2,000 gallons per day.

Process and application details can be found via an internet search for “CDPHE Commerce and Industry Permitting” or online (<https://www.colorado.gov/pacific/cdphe/clean-water-commerce-and-industry-permitting>).

1406 FLOODPLAIN REGULATIONS AND PERMITTING

FEMA and Boulder County both maintain regulatory floodplains within the county. While most of the county’s regulated floodplains are also regulated by FEMA, some are not. Additionally, the Colorado Water Conservation Board (CWCB) has established regulations that govern all floodplains in Colorado. The three sets of regulations and requirements are discussed briefly below, and references are included that will provide additional information. If more than one set of regulations applies to a regulatory floodplain, the more stringent set of regulations will govern.

1406.1 Boulder County Floodplain Regulations

Boulder County floodplain regulations will govern when it comes to complying with development standards, changes to the floodplain extents or elevations, and permitting issues within a designated floodplain. A Floodplain Overlay (FO) Zoning District is established by the CODE. The CODE also offers detailed information on the restrictions and requirements associated with various portions of the FO district and the definitions of several relevant terms, including “floodway” and “floodfringe.” The restrictions and requirements in the CODE are intended to provide a reasonable degree of flood protection to the county. The CODE can be found via an internet search for “Boulder County Land Use Code” or online (<http://www.bouldercounty.org/property/build/pages/lucode.aspx>).

Development within the floodway and floodfringe is discouraged. Restrictions on development in the floodway or floodfringe are nuanced and should be reviewed carefully. Floodway delineations adopted by Boulder County that are more restrictive than those adopted by FEMA shall govern. A floodplain development permit is required for all development within the FO district or regulatory floodplain, regardless of whether or not there is a change in the 100-year water surface elevation. The CODE includes the submittal requirements for the floodplain development permit. Additional information on this permit can be found via an internet search for “Boulder County floodplain development permit” or online (<http://www.bouldercounty.org/roads/permits/pages/floodcontrol.aspx>).

1406.2 Colorado Water Conservation Board Floodplain Regulations

Floodplains in Colorado are regulated by the Colorado Water Conservation Board (CWCB) in accordance with *Rules and Regulations for Regulatory Floodplains in Colorado* (CWCB, 2010), which were developed to limit the impacts of floods and to preserve health, safety, welfare, and property by limiting development in floodplains. These rules and regulations can be found via an internet search for “CWCB floodplain regulations” or online (http://cwcb.state.co.us/Documents/FloodplainRulesReqsUpdate/CWCB_Adptd_FP_Rules_BasisPurp_%2011172010.pdf). State regulations are subject to change and should be evaluated at the beginning of each project.

1406.3 Federal Emergency Management Agency Floodplain Requirements

Communities that participate in the National Flood Insurance Program (NFIP) must meet FEMA minimum requirements. Boulder County is one such community. Any development within a FEMA-regulated floodplain that results in a change to the existing regulatory floodway, the effective base flood elevation (BFE), or the lateral extents of the 100-year floodplain requires a CLOMR before construction. A Letter of Map Revision (LOMR) is then required once construction is complete. Regardless of which floodplain regulations govern, applications for all CLOMRs and LOMRs are made to and issued by FEMA. The requirements of the CLOMR and LOMR process, along with associated fees, may be found by searching the FEMA website (www.fema.gov).

1407 COUNTY PERMITTING

All projects must adhere to and comply with the codes, permitting requirements, and regulations specific to the jurisdictions in which they are located, in this case Boulder County. Detailed analysis at the beginning of each project will be required to determine specific permit requirements and necessary

compliance measures. At the discretion of the county, maintenance eligibility guidelines published by the UDFCD should also be adhered to when deciding what improvements to natural channels will be included, provided the county wishes a project to be qualified by the UDFCD as maintenance eligible.

1407.1 Boulder County Stormwater Quality Permit

The CODE specifies when a stormwater quality permit is required and provides for limited exemptions. A stormwater quality permit will be required for all work in an active waterway. Allowable changes and required amendments to the issued county stormwater quality permit are included in the CODE. Compliance with the county permit once construction is complete is also discussed in the CODE.

The CODE also includes information on the application approval process, enforcement and penalties, administrative appeals, and related provisions. Standard operating procedures for many of the aspects of the stormwater quality permit have been developed by the county and are subject to revision. The county should be contacted at the beginning of any project to determine applicable procedures.

1407.2 Additional Boulder County Permits

In addition to the floodplain development permit discussed in 1406, the county also requires and issues building, construction, grading, and access permits.

A building permit is required for any construction that physically changes or adds structures to a property, or for work regulated by county codes. Information regarding building permits can be found online (<http://www.bouldercounty.org/property/build/pages/buildingpermitreqs.aspx>) or via an internet search for "Boulder County building permits."

A construction permit is needed to construct or maintain any road, drainage, or other improvement within county right-of-way. Additional information on construction permits can be found online (<http://www.bouldercounty.org/roads/permits/pages/constructpermit.aspx>) or via an internet search for "Boulder County construction permit."

A grading permit is required for grading, excavation, or placement of fill in excess of 50 cubic yards, with certain exceptions. Information on grading permits can be found via an internet search for "Boulder County Grading Permit" or online (<http://www.bouldercounty.org/doc/landuse/b17gradingpermitreqs.pdf>). A grading permit typically requires a soil erosion and sedimentation plan in accordance with the CODE. The requirements of a soil erosion and sedimentation plan are currently included in the CODE.

An access permit is needed to construct any driveway providing vehicular access to or from any county right-of-way. Additional information on access permits can be found via an internet search for "Boulder County access permit" or online (<http://www.bouldercounty.org/roads/permits/pages/accesspermit.aspx>).

1408 MISCELLANEOUS PERMITTING CONSIDERATIONS

Preapplication meetings with the USACE and other regulatory agencies are encouraged by the USACE to facilitate the review of potentially complex or controversial projects, or projects that could have significant impacts on the human environment. Pre-application meetings can help streamline the permitting process by alerting the applicant to potentially time-consuming concerns that are likely to arise during the evaluation of their project.

Compliance with state or federal permitting requirements does not preclude the need to comply with county regulations, standards, or criteria. If necessary, joint discussions between all regulatory agencies should be initiated during the project planning stages and continued as needed.

1409 REFERENCES

Colorado Water Conservation Board, 2010. *Rules and Regulations for Regulatory Floodplains in Colorado*, prepared for the Colorado Department of Natural Resources, Colorado Water Conservation Board, Denver, CO.

Colorado Department of Transportation, 2002. *Erosion Control and Stormwater Quality Guide*, revised Chapter 5 EC 5&6 July 2014, prepared by the Colorado Department of Transportation, Denver, CO.

Urban Drainage and Flood Control District, 2016. *Urban Storm Drainage Criteria Manual: Volume 3 Stormwater Quality*, prepared by the Urban Drainage and Flood Control District, Denver, CO.

APPENDIX A

Bioengineering Components Schematic Details

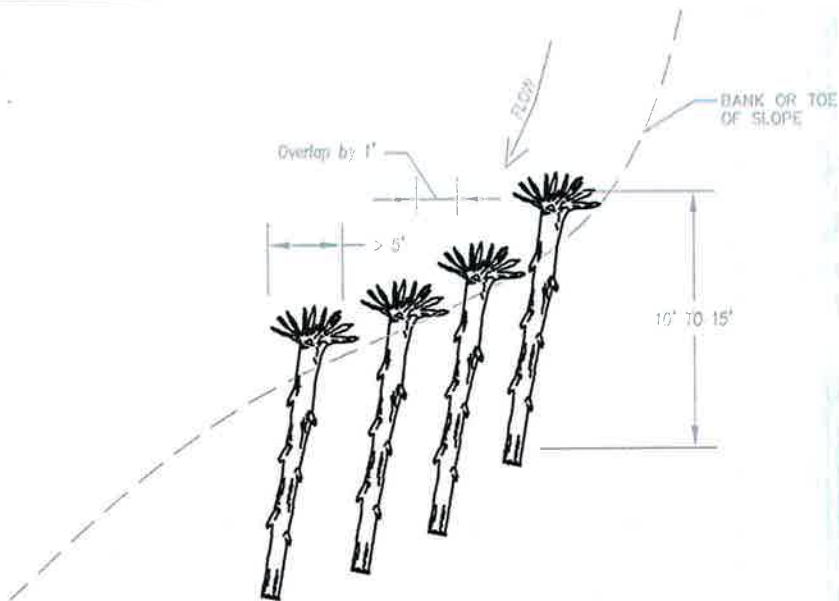

1 ROOTWAD PLACEMENT EXAMPLE PLAN VIEW

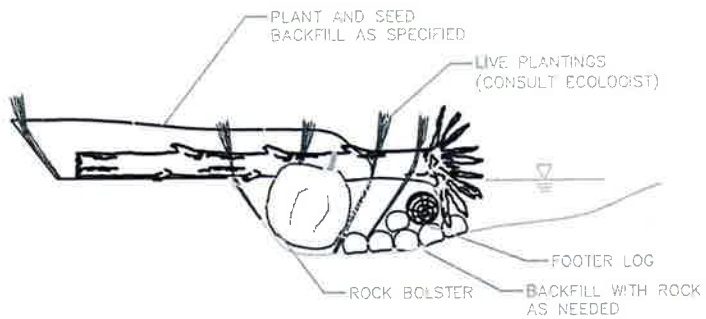

2 ROOTWAD ANCHORED WITH ROCK BOLSTER

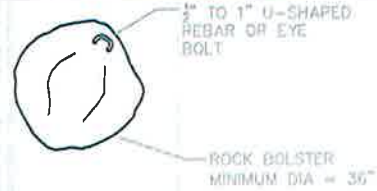

3 ROCK BOLSTER DETAIL

Notes:

Secure logs to rock bolsters at overlap with a minimum of three wraps of $\frac{3}{8}$ " diameter galvanized non-greased, wire rope. Drill holes in rock bolsters with gas or pneumatic drill. The min. depth should be 6". Holes must be clean of all dust, debris, oil, and soap following drilling. Insert a U-shaped or eyebolt rebar into holes several times to dispense and completely mix epoxy and eliminate air pockets. Epoxy resin systems shall meet the requirements of ASTM C881, Type IV Grade 3. Test strength of bond after minimum cure time recommended by the epoxy manufacturer.

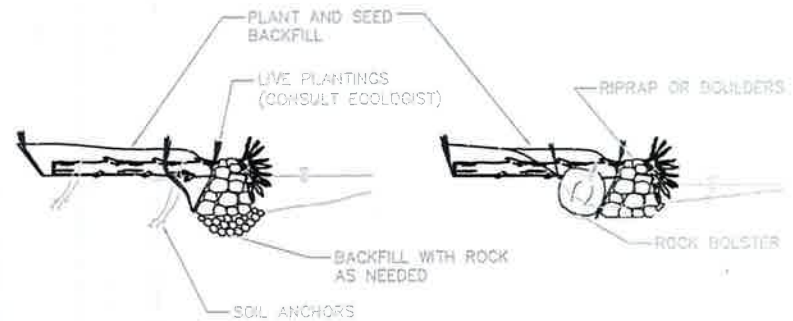

4 ROOTWAD PLACEMENT WITH RIPRAP TOE INSTEAD OF FOOTER LOG

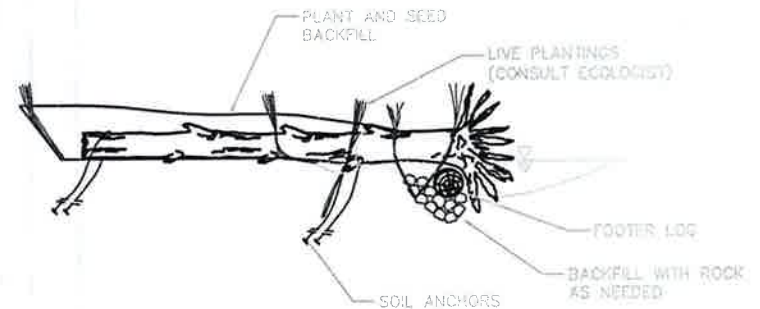

5 ROOTWAD ANCHORED WITH SOIL ANCHORS

NO.	REVISION	DATE	BY	DATE

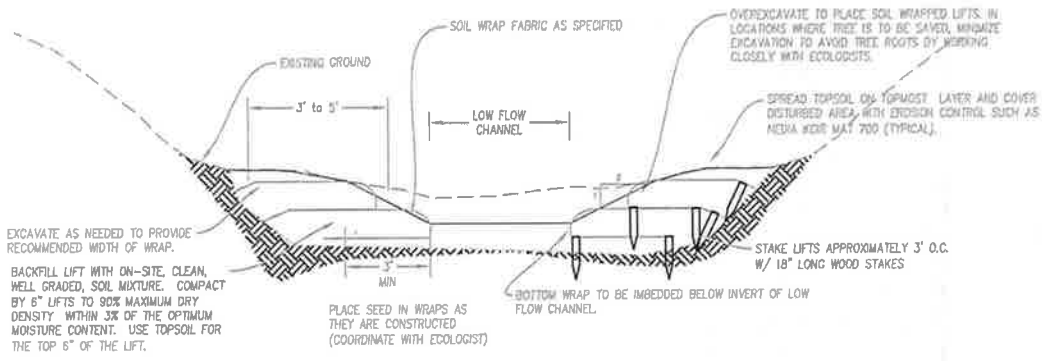

1 SOIL WRAPPED LIFT LOW FLOW CHANNEL EXAMPLE

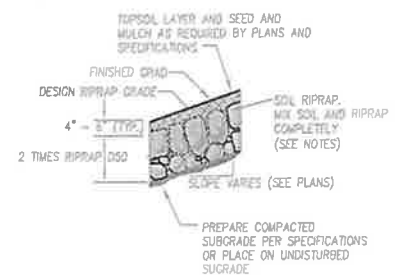

2 SOIL RIPRAP WITH MULCH EXAMPLE

- NOTES**
1. SOIL RIPRAP DETAILS ARE APPLICABLE TO SHALLOW CHANNELS. REFER TO THE CIVIL PLAN ACTUAL LOCATION AND GRADE.
 2. MIX UNIFORMLY AND RIPRAP BY VOLUME WITH 50% OF APPROVED SPEC. TOPSOIL PRIOR TO PLACING.
 3. PLACE STONE OVER MIX TO RESULT IN SECURELY INTERLOCKED BARS AT THE DESIGN THICKNESS AND BENCH, COMPACT AND LEVEL TO ELIMINATE ALL VOIDS AND ROCKS PROJECTING ABOVE DESIGN RIPRAP TOP GRADE.
 4. CRIMP OR TACKLE BRANCH OR USE APPROVED HYDROMULCH AS CALLED FOR IN THE PLANS AND SPECIFICATIONS.
 5. MULCH SHALL NOT BE USED IN THE CHANNEL BOTTOM AND SLOPES EXPOSED TO FREQUENT FLOODING.

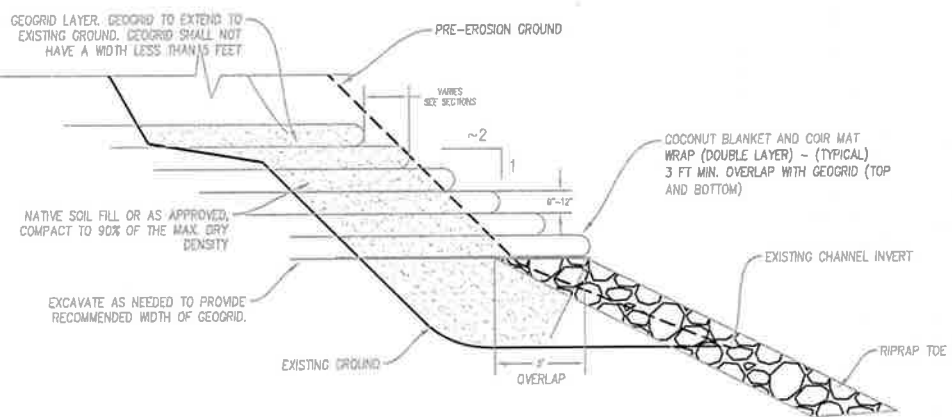

3 SOIL WRAP LIFTS FOR STEEP BANKS EXAMPLE

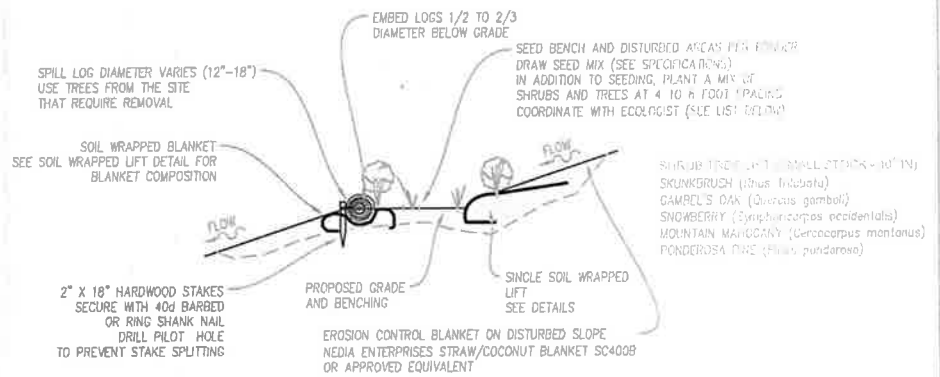

4 LOG GRADE BANK STABILIZATION- EXAMPLE



THESE DRAWINGS ARE THE PROPERTY OF ERM CONSULTANTS AND ARE NOT TO BE REPRODUCED FOR CONSTRUCTION.

NO.	REVISION/DESCRIPTION	BY	DATE

SOIL RIPRAP, SOIL LIFTS LOW FLOW CHANNEL, AND SOIL LOG BANK STABILIZATION ECOLOGICAL CONNECTIVITY AND DESIGN PROJECT

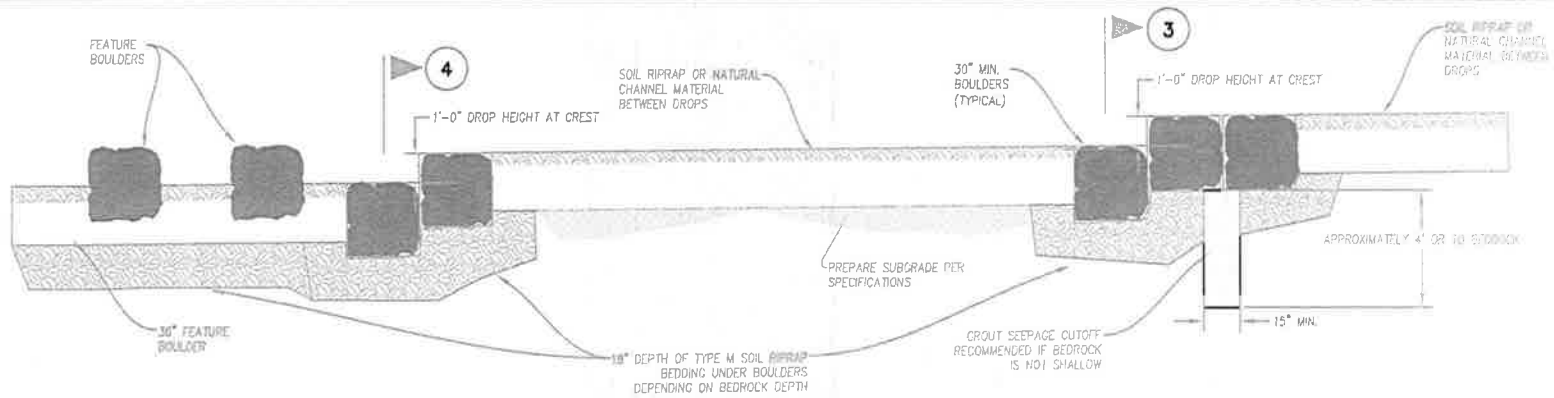

2 CHECK STRUCTURE DROP EXAMPLE - PROFILE

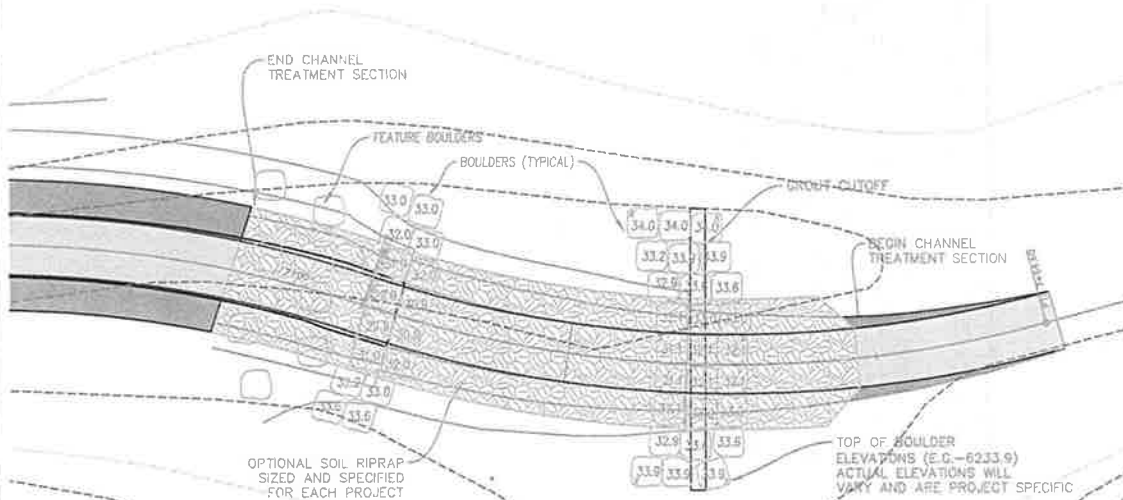

1 CHECK STRUCTURE EXAMPLE PLAN VIEW

- NOTES:
1. BOULDER PLACEMENT SHALL BE STEPPED IN ACCORDANCE WITH THE TOP OF BOULDER ELEVATIONS SHOWN ON THE PLAN.
 2. BOULDERS SHALL BE PLACED WITH THE TOP FLAT UNLESS OTHERWISE DESIRED BY THE ENGINEER.
 3. BOULDERS SHALL BE PLACED SUCH THAT ADJACENT BOULDERS TOUCH EACH OTHER AND JOINTS ARE INTERLOCKED (LIKE A PEEZLE). A MINIMUM VERTICAL OVERLAP OF 6" SHALL BE MAINTAINED FROM ONE BOULDER TO THE NEXT. ALL BOULDER PLACEMENT SHALL BE APPROVED BY THE ENGINEER DURING CONSTRUCTION.

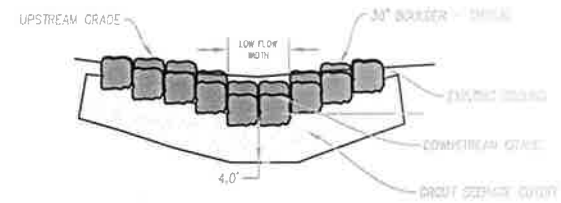

3 UPSTREAM BOULDER DROP SECTION

NTS

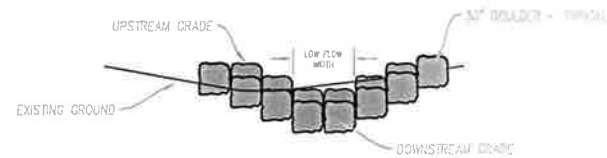

4 DOWNSTREAM BOULDER DROP SECTION

NTS



PREPARED BY
ENGINEERS CONSULTING SOLUTIONS
 10018 ROCKY MOUNTAIN AVENUE, SUITE 215
 LITTLETON, COLORADO 80120
 PH: 303-972-9112
 FX: 303-972-6104

THESE DRAWINGS ARE FOR ILLUSTRATIVE PURPOSES ONLY AND ARE NOT INTENDED FOR CONSTRUCTION.

NO.	REVISION DESCRIPTION	BY	DATE

CHECK STRUCTURE EXAMPLE
ECOLOGICAL DESIGN AND CONNECTIVITY PROJECT

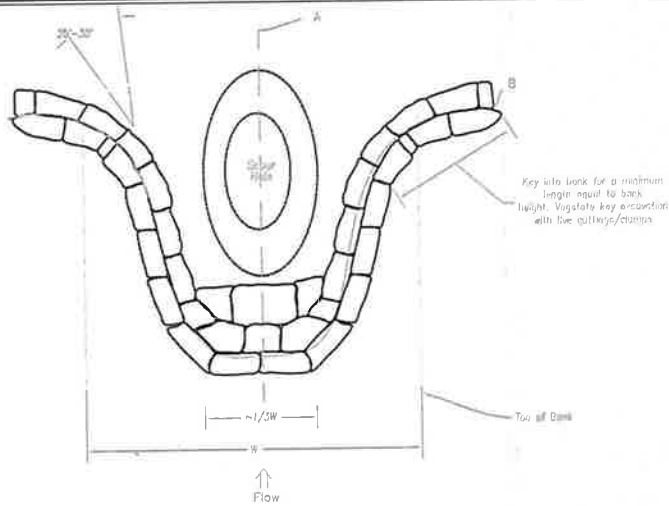

1 ROCK VANE PLAN VIEW

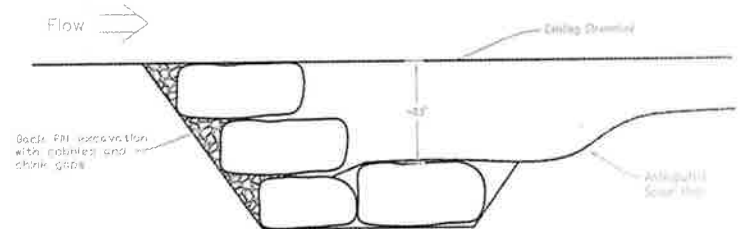

3 ROCK BOLSTER DETAIL

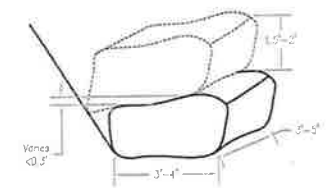

4 TYPICAL ROCK DIMENSIONS AND PLACEMENTS

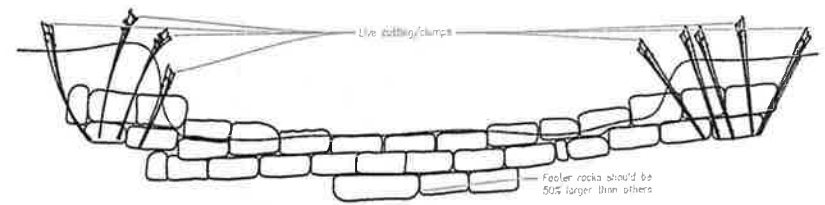

5 ROCK VANE SECTION B

Notes: The rocks should be rectangular or nearly so at the rock to rock contact. The rock to rock contact should be solid. If rocks are not perfectly flat, the thicker end should be placed downstream.

NO.	REVISION/DESCRIPTION	BY	DATE

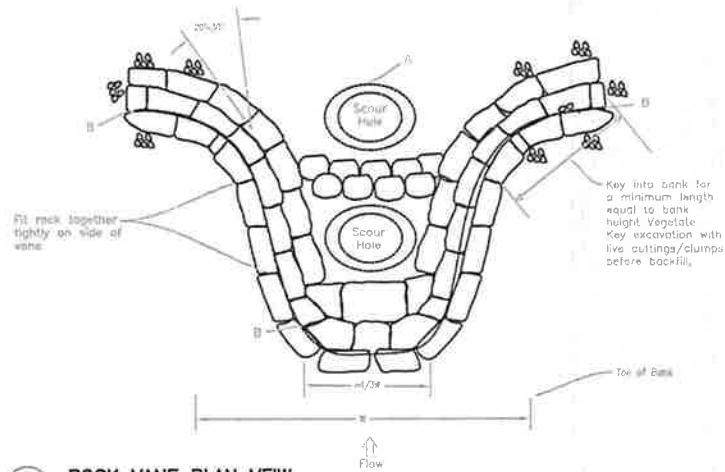

1 ROCK VANE PLAN VIEW

*Notes (1): Total drop not to exceed 6 inches for warm water fish species

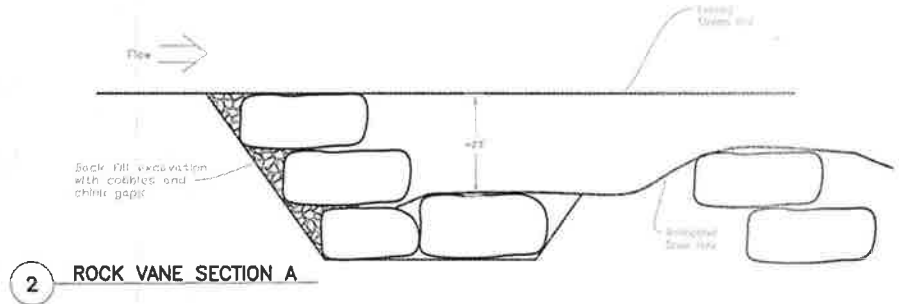

2 ROCK VANE SECTION A

Notes (3): Stone size to be stable at highest design discharge

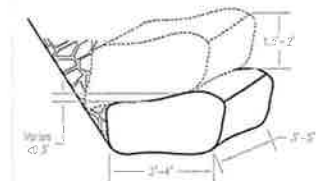

4 TYPICAL ROCK DIMENSIONS AND PLACEMENTS

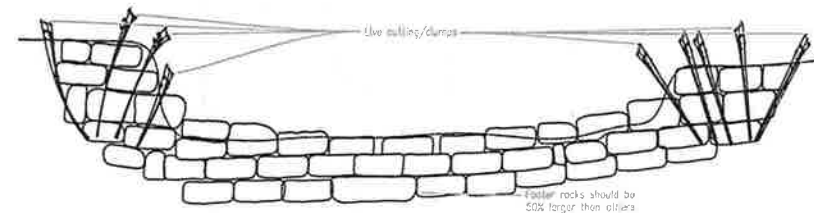

2 ROCK VANE SECTION B

General Notes: The rocks should be rectangular or nearly so at the rock to rock contact. The rock to rock contact should be solid. If rocks are not perfectly flat, the thicker end should be placed downstream. Fill gaps with smaller stones.



PREPARED BY: ENVIROTECH CONSULTING GROUP, INC.
 1000 17TH STREET, SUITE 200
 BOULDER, COLORADO 80502
 TEL: 303-442-6100
 WWW.ENVIROTECHGROUP.COM

ENGINEERED AND DESIGNED BY: ENVIROTECH CONSULTING GROUP, INC.
 FOR CONSTRUCTION

DATE	BY	CHK

STEPPED POOL ROCK CROSS VANE EXAMPLE
ECOLOGICAL DESIGN AND CONNECTIVITY PROJECT

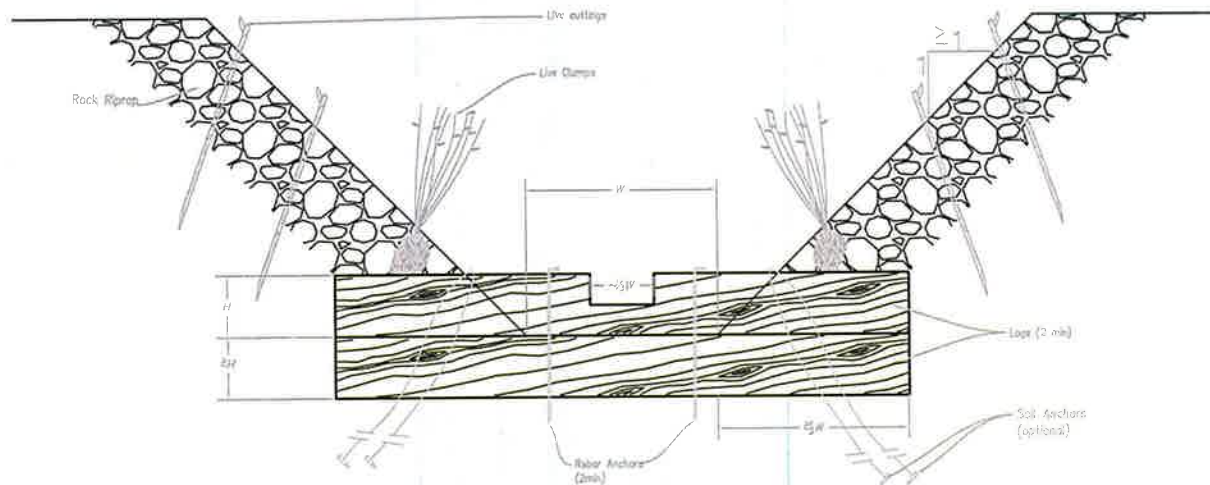

Notes: Install UIC clamps and UIC collars into adjacent protection during construction. Extend to slope stream bank. Use logs that are straight, uniform diameter and free of rot, disease or insect infestation.

1 FRONT VIEW OF LOG CHECK

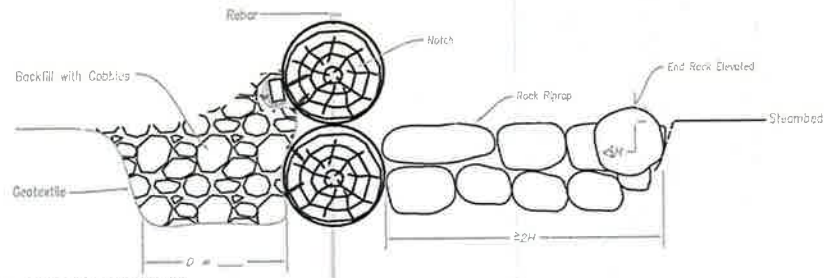

2 CROSS-SECTION

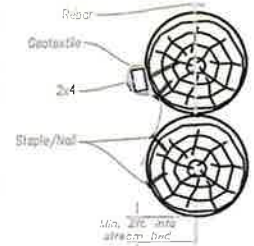

3 CROSS-SECTION LOG

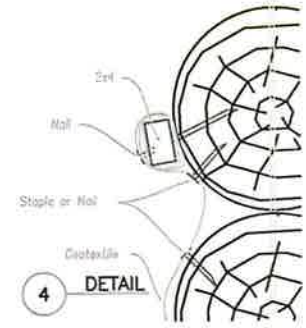

4 DETAIL

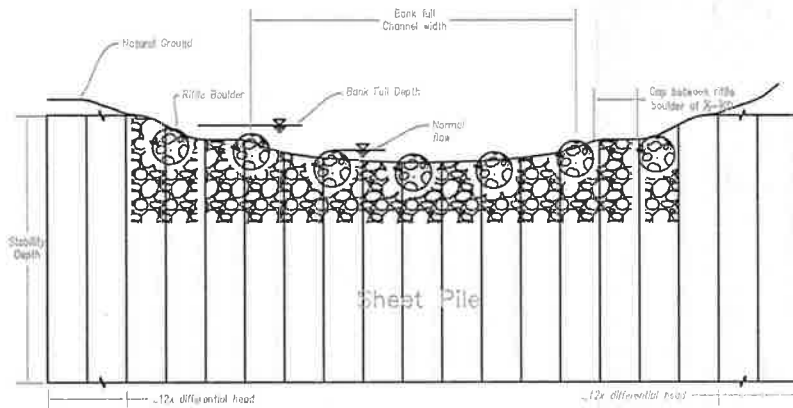

1 CHUTE SECTION VIEW

Notes (1): Sheet pile to follow natural ground to high bank.

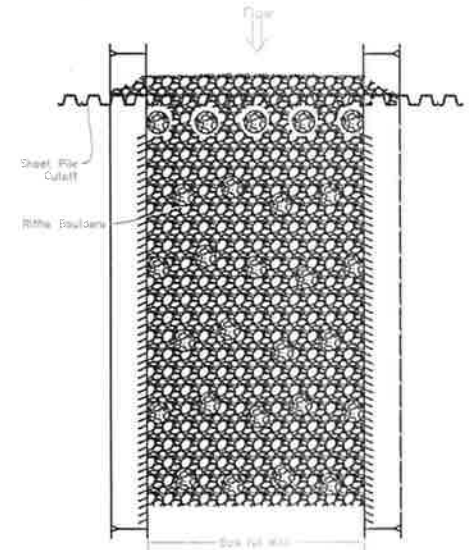

2 CHUTE PLAN VIEW

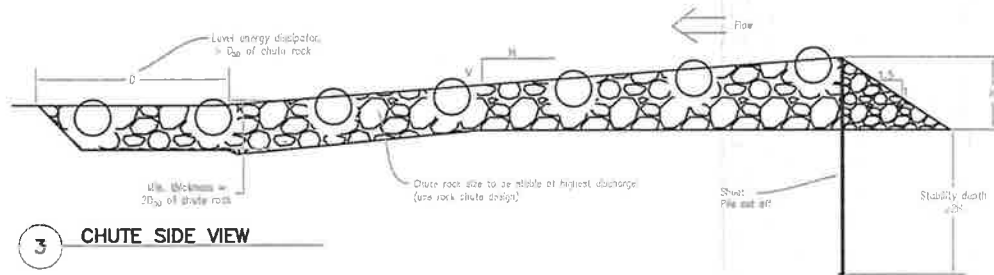

3 CHUTE SIDE VIEW

General Note: Maximum slope for warm water species is 5%. Maximum slope for salmonids is 10%.

Notes (2): Plant edge with live cuttings. Offset riffle boulders so flow is circuitous.

Notes (4): Riffle boulder typical 1.5 to 2.5x Dia. of rock in chute. Riffle boulders should be seated in the rock mantle of the chute.

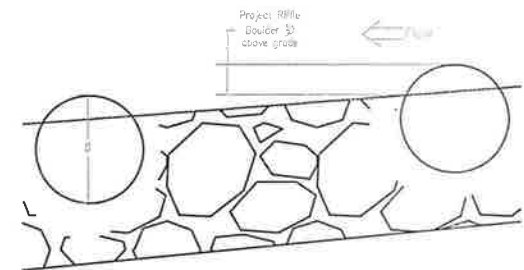

4 CLOSE UP CHUTE SIDE VIEW

NO.	REVISION	BY	DATE

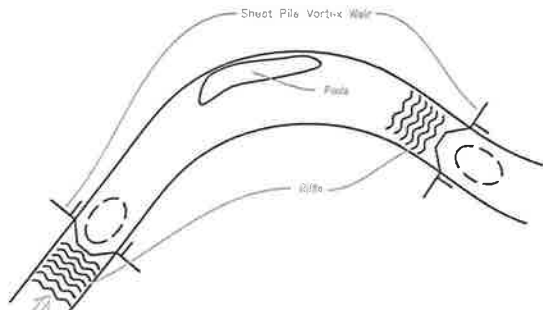

1 WEIR LAYOUT

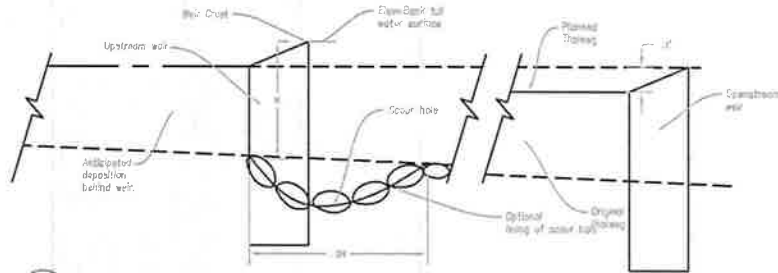

2 WEIR PROFILE VIEW

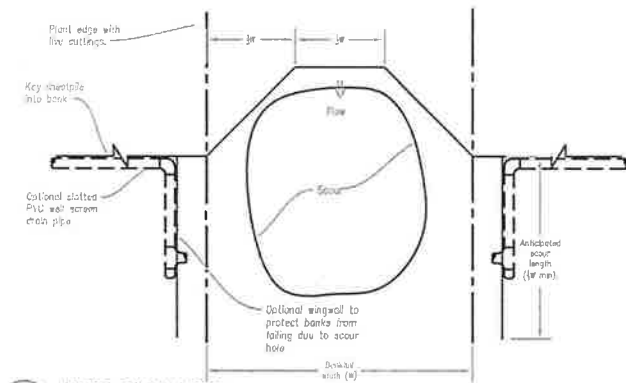

3 WEIR PLAN VIEW

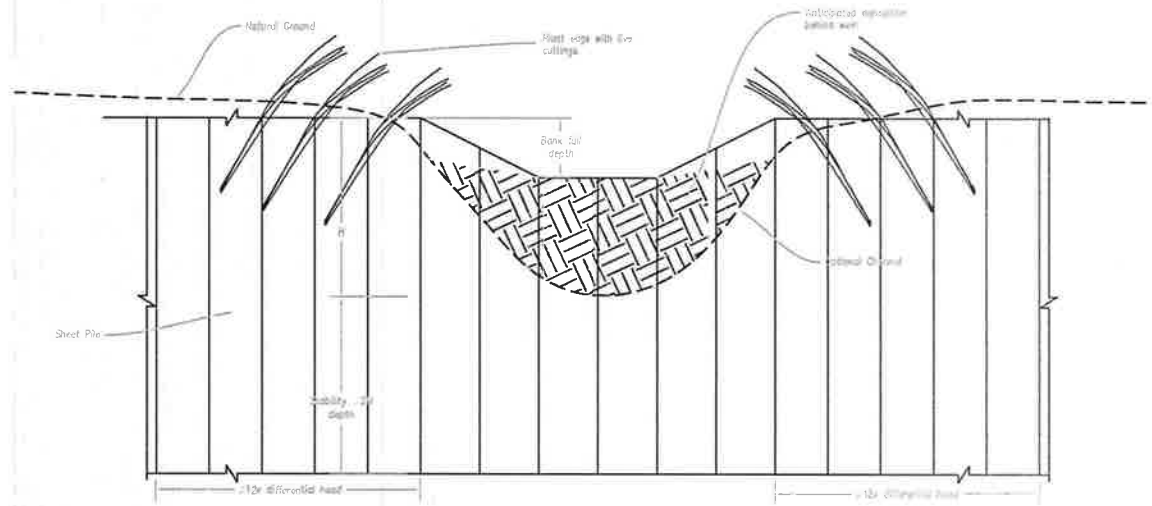

4 WEIR SECTION VIEW

	PREPARED BY: DIAGNOSTIC ENGINEERING SOLUTIONS 1000 WEST SAN CARLOS AVE., 4TH FLOOR, SAN JOSE, CA 95128 TEL: 408-972-0114 FAX: 408-972-0104 	THESE DRAWINGS ARE FOR EXAMPLE PURPOSES ONLY AND ARE NOT INTENDED FOR CONSTRUCTION.	APPROVED BY: _____ DATE: _____ CHECKED BY: _____ DATE: _____	<table border="1"> <thead> <tr> <th>REVISION</th> <th>DESCRIPTION</th> <th>BY</th> <th>DATE</th> </tr> </thead> <tbody> <tr> <td> </td> <td> </td> <td> </td> <td> </td> </tr> <tr> <td> </td> <td> </td> <td> </td> <td> </td> </tr> <tr> <td> </td> <td> </td> <td> </td> <td> </td> </tr> </tbody> </table>	REVISION	DESCRIPTION	BY	DATE													<p align="center">SHEET PILE VORTEX WEIR ECOLOGICAL DESIGN AND CONNECTIVITY PROJECT</p>	SHEET NO. 9 OF 18
	REVISION	DESCRIPTION	BY	DATE																		
	COUNTY OF SANTA CLARA DEPARTMENT OF TRANSPORTATION 2202 JPM CENTER SAN JOSE, CALIFORNIA 95131																					

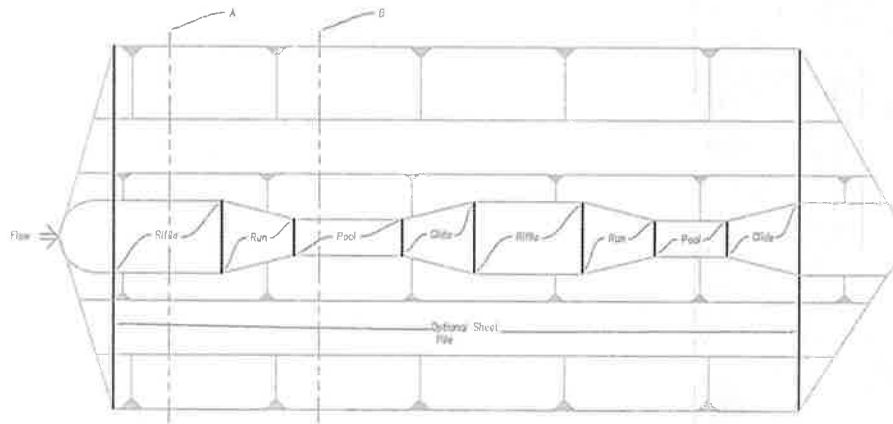

1 PLAN VIEW

Notes (1):
 Slope Riffle (S_{RF}) = ____ ($\sim 1.5S_0$ to $2S_0$)
 Slope Run (S_{RN}) = ____ ($\sim 2S_0$)
 Slope Pool (S_P) = ____ (0 to $\frac{1}{2}S_0$)
 Slope Glide (S_G) = ____ ($-S_{RN}$)
 (Slope from beginning of run to the end of the glide should be $< \frac{1}{2}$ of riffle slope)

Notes (1): Bottom width of pool is $\sim \frac{1}{2}$ the bottom width of riffle

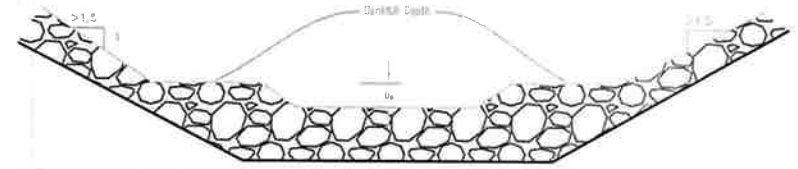

2 SECTION A-RIFFLE

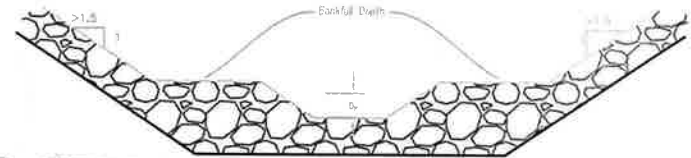

3 SECTION B-POOL

Notes (3 and 4):
 D_R = ____ (Bankfull depth)
 D_P = ____ (~ 2 to $3D_R$)

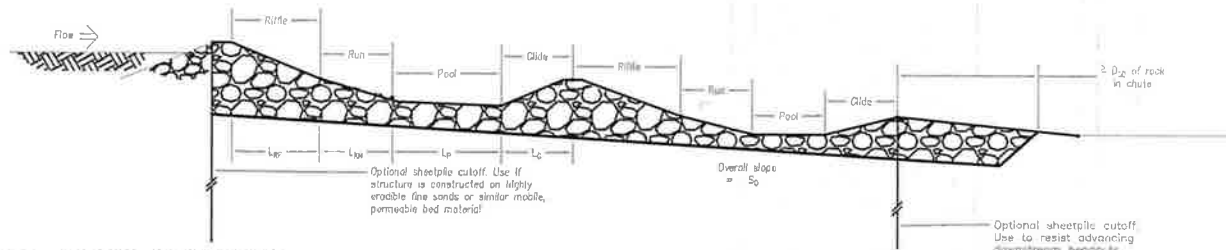

4 PROFILE (CENTERLINE)

General Notes:
 • Chute rock size to be stable at highest design discharge (use rock chute design and apply results to riffle slope)
 • Minimum rock thickness shall not be less than $2D_{50}$
 • Design was originally developed for a Rosgen C stream

Notes (2):
 L_{RF} = ____
 L_{RN} = ____ ($\sim \frac{2}{3}L_{RF}$)
 L_P = ____ ($\sim L_{RF}$)
 L_G = ____ ($\sim L_{RN}$)
 (Length of riffle $\sim \frac{1}{2}$ length of entire pool including run, pool and glide as shown on the plans)
 $L_{RF} \sim \frac{1}{2} (L_{RN} + L_P + L_G)$



THESE DRAWINGS ARE FOR GENERAL INFORMATION ONLY AND ARE NOT INTENDED FOR CONSTRUCTION

NO.	DESCRIPTION	BY	DATE

**STEPPED-POOL ROCK CHUTE EXAMPLE
 ECOLOGICAL DESIGN AND CONNECTIVITY PROJECT**

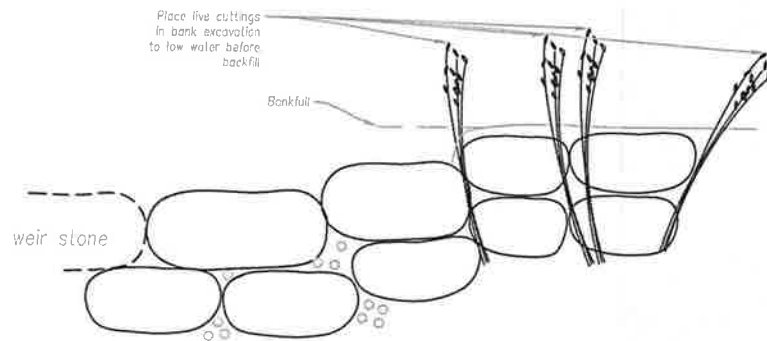
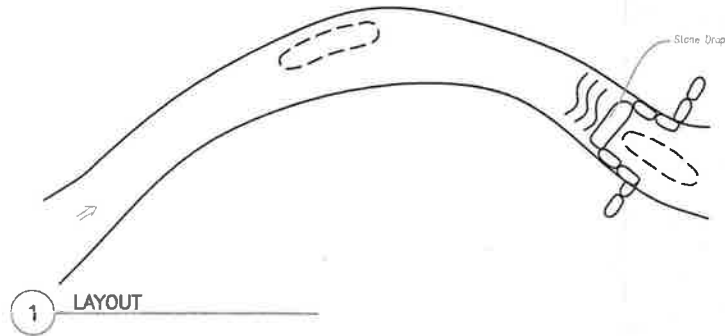

General Notes: The rocks should be rectangular or nearly so at the rock to rock contact. The rock to rock contact should be solid. If rocks are not perfectly flat, the thicker end should be placed downstream. Fill gaps with smaller stones.

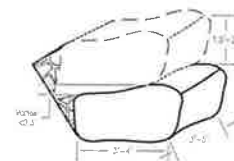
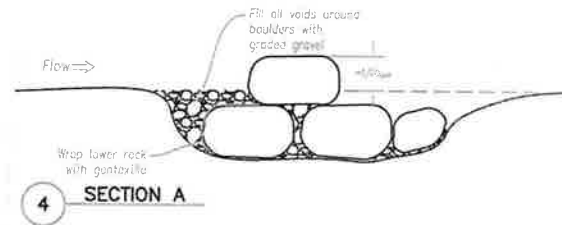
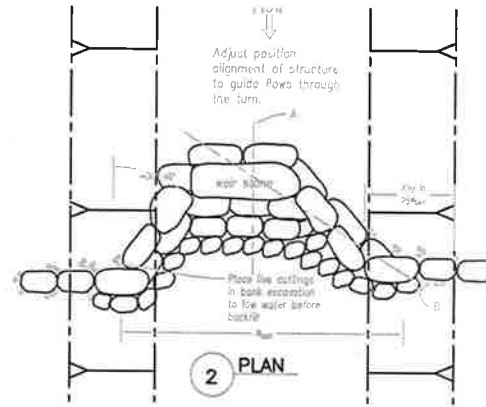

Notes (4): Stone size to be stable at highest design discharge.

NO.	DESCRIPTION	BY	DATE

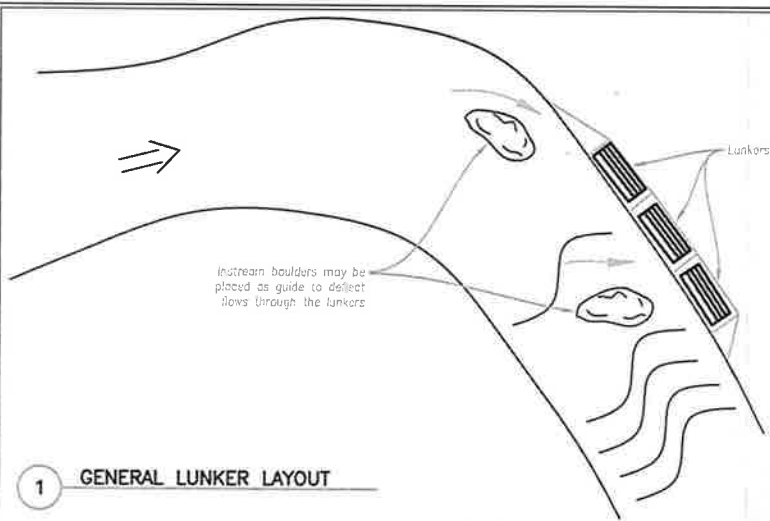

1 GENERAL LUNKER LAYOUT

Notes (1): Typically place lunkers in sets of three on the outer and lower $\frac{1}{3}$ of the channel bank. Final alignment and placement should be determined in the field at low water. The designer should observe the current patterns to assure that flow will pass into and out of the structures. The designer should also assure that the Lunkers are placed below low water elevation.

Stone Lunker (A)

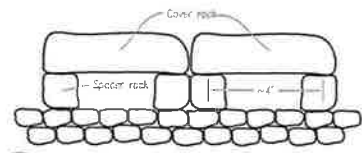

3A FRONT

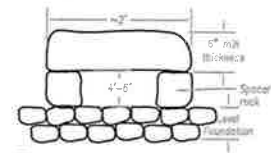

2A SIDE

Stone Lunker Notes: Use sound rock. Place so that there is solid contact and no movement

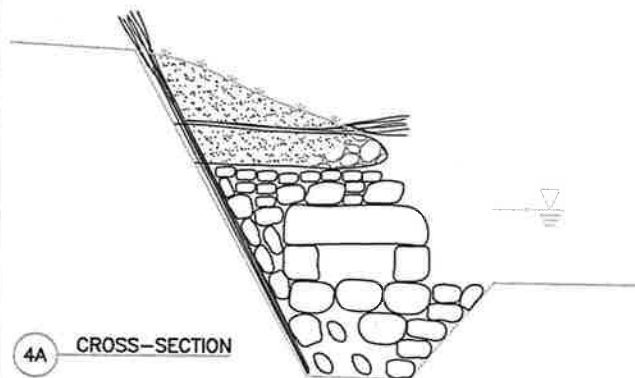

4A CROSS-SECTION

Wood Lunker (B)

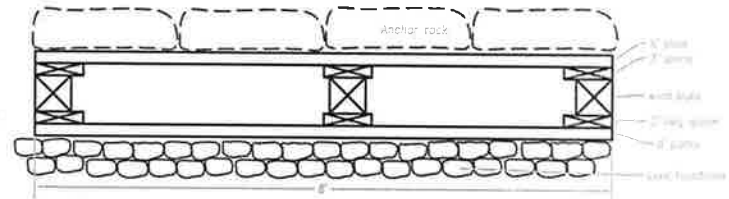

1B FRONT

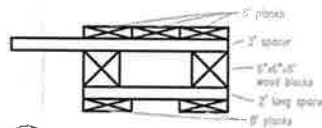

2B SIDE

Wood Lunker Notes: Lunker material is rough cut hard wood at least 2" thick

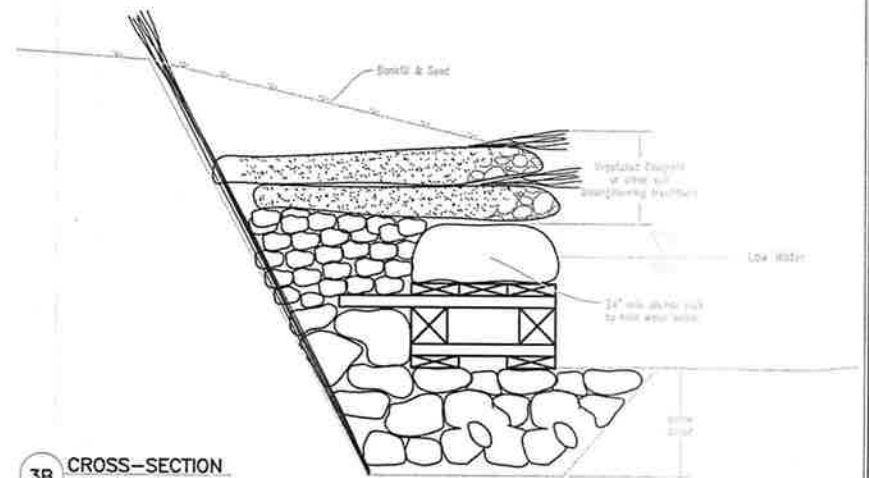

3B CROSS-SECTION



THESE DRAWINGS ARE FOR EXAMINE PURPOSES ONLY AND ARE NOT INTENDED FOR CONSTRUCTION.

NO.	REVISION/DESCRIPTION	BY	DATE

LUNKER FISH HABITAT OPTIONS
ECOLOGICAL DESIGN AND CONNECTIVITY PROJECT

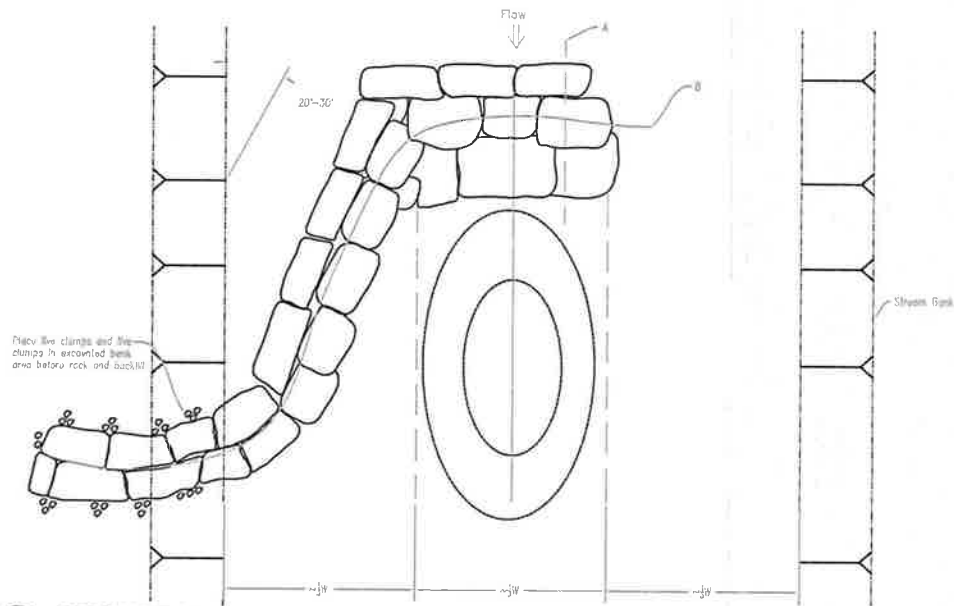

1 HOOK VANE PLAN VIEW

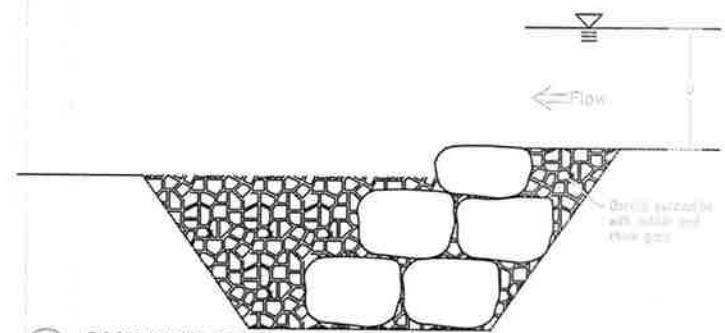

2 ROCK VANE SECTION A

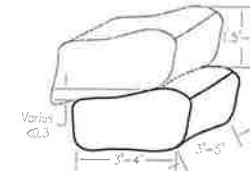

3 TYPICAL ROCK DIMENSIONS AND PLACEMENTS

Notes (3): Stone sized to be stable highest design discharge

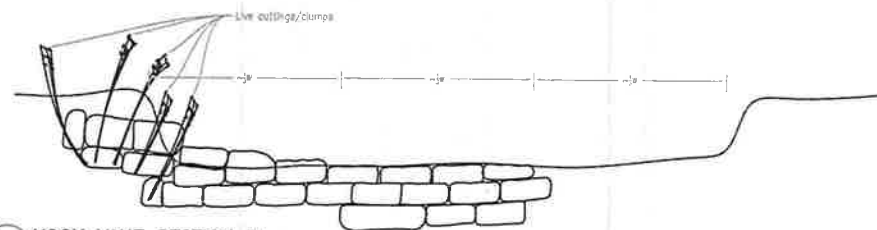

4 HOOK VANE SECTION B

General Notes: The rocks should be rectangular or nearly so at the rock to rock contact. The rock to rock contact should be solid, if rocks are not perfectly flat, the thicker end should be placed downstream.

NO.	REVISION/DESCRIPTION	BY	DATE

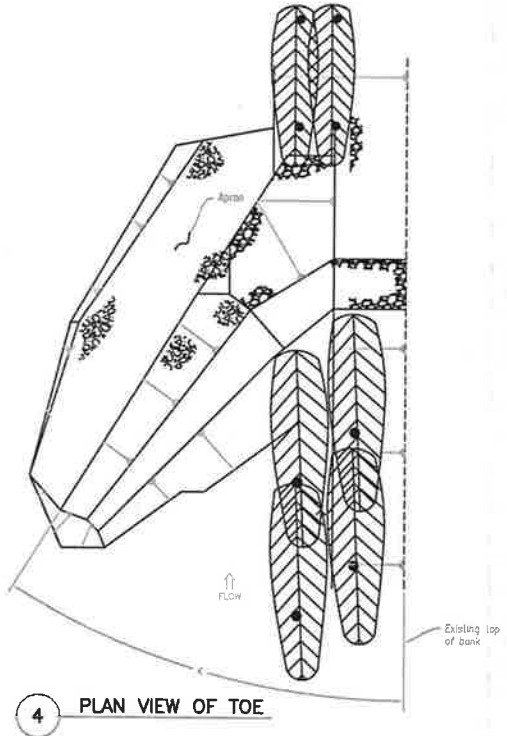

Notes (1):
 Install vertical bundles as directed in field. Base of bundles need to be at or below phreatic line. Install with rock.

L= _____
 L= _____
 H_A= _____
 H_B= _____

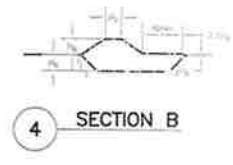
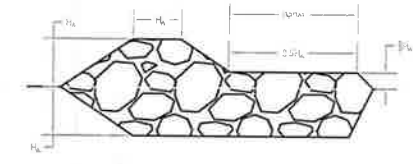
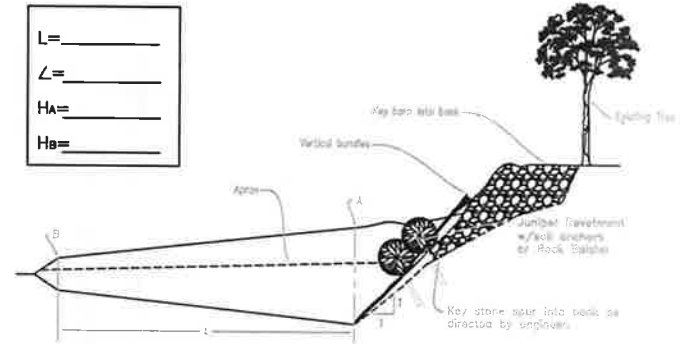

DATE	DESCRIPTION	BY	DATE

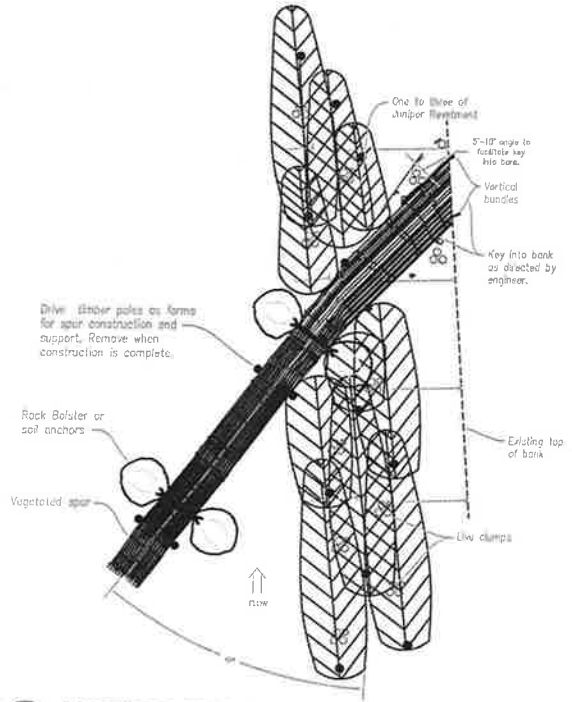

1 VEGETATIVE SPUR WITH JUNIPER REVETMENT

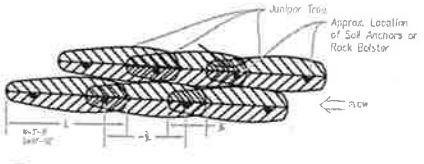

2 JUNIPER REVETMENT

Notes (1): Trees in revetment shall be lightly secured to bank and in firm contact with spur. Trees are continuous over spur and are shown as ending only for clarity of drawing.

Notes (2): Overlap juniper by $\frac{1}{4}$ to $\frac{1}{3}$ length in a shingle-like arrangement. Secure at overlap with three wraps of 12 gage wire or $\frac{3}{8}$ " cable and clamp securely. Anchor with a minimum of two sets of soil anchors or rock bolsters per trunk as per specifications. Start at toe of bank. If additional rows are required, offset by not more than tree width. Press rows tight together. Cable rows together with 12 gage wire or $\frac{3}{8}$ " cable and clamp.

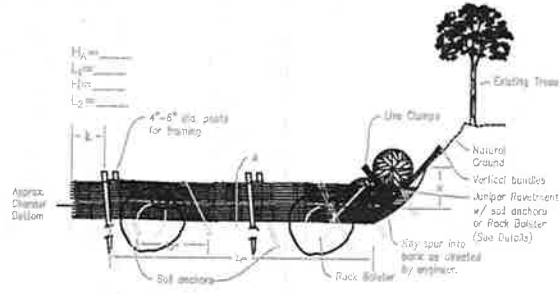

3 VEGETATED SPUR

Notes (3):
 1) Remove loose and failing bank material, excavate key into bank as shown.
 2) Excavate trench along alignment of bank at depth as shown. Trench should be a minimum of $\frac{1}{2}$ thickness of vegetated spur at section A.
 3) Install two pairs of framing posts at width of spur.
 4) Place live material tightly between framing posts. Butt ends shall be fitted into bank as length of material permits.
 Material shall overlap by $\frac{1}{2}$ - 1".
 5) Install soil anchors in pairs at Rock Bolster as specified.
 6) Tightly secure live material to soil anchors with ratcheting cable clamps.
 7) Place vertical bundles into key area as shown. Butt ends of live material must extend 10" to soil.
 8) Backfill over key.
 9) Install juniper revetment over spur as bank is specified.

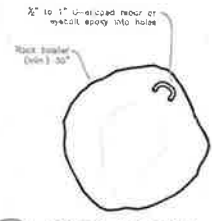

4 ROCK BOLSTER

Notes (4): Secure logs to rock bolsters at overlap with a minimum of three wraps of $\frac{3}{8}$ " diameter galvanized non-greased, wire rope. If constructing in or near water drill holes in rock bolsters with gas or pneumatic drill. Holes must be clean of all dust, debris, oil, and soap following drilling. Insert a U-shaped 1" rebar into holes several times to dispense and completely mix epoxy and eliminate air pockets. Epoxy resin systems shall meet the requirements of ASTM C881, Type IV Grade 3. Test strength of bond after minimum cure time recommended by the epoxy manufacturer.

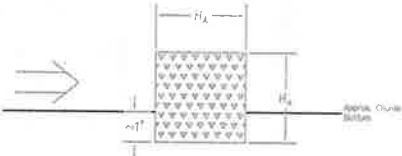

4 SECTION A

Cross-Sectional Views Describing Installation

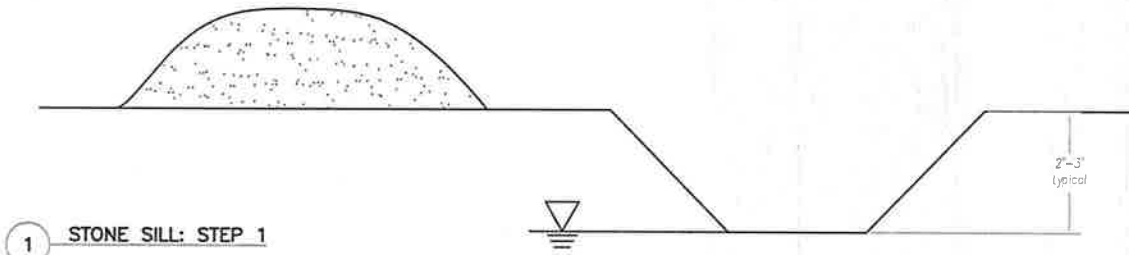

Notes (1):
 • Excavate trench ideally to low water

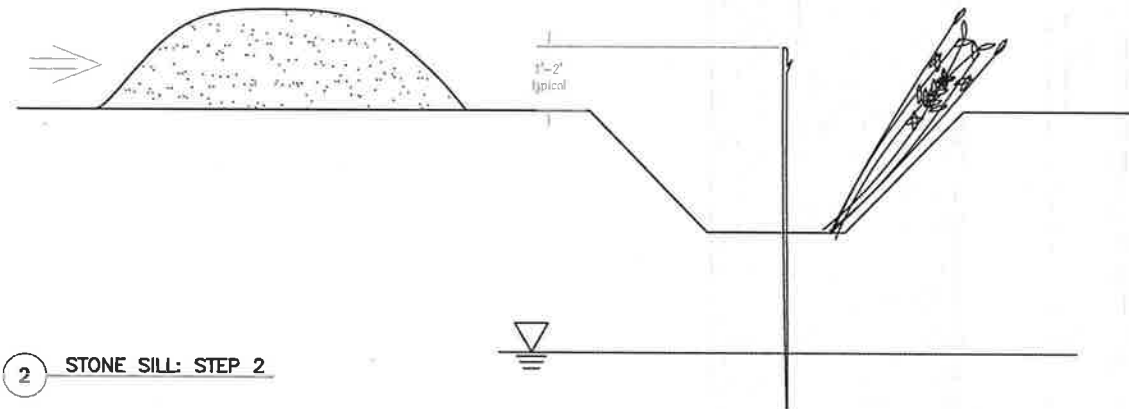

Notes (2):
 • Install live poles on 4 to 8 ft. centers if trench may not reach reliable water table.
 • Place a mix of live and dead cuttings along downstream side of trench (approximately 12-15 per ft of trench).

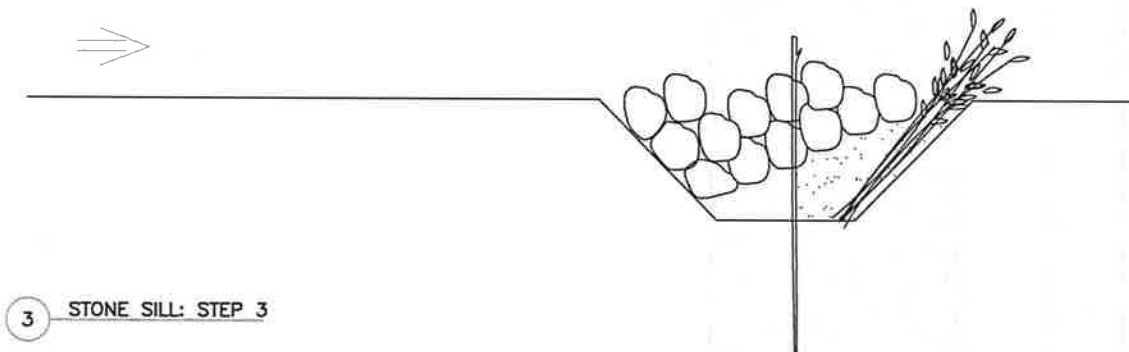

Notes (3):
 • Cover cuttings with soil and wash in to achieve good soil to stem contact.
 • Place appropriately sized stone in trench (12" minus typical). Irrigate live cuttings for establishment if trench does not reach reliable water table.

REVISION	DESCRIPTION	BY	DATE

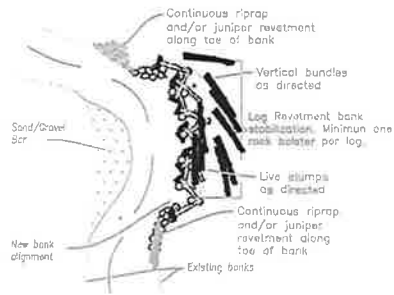

1 FULL REVETMENT LAYOUT

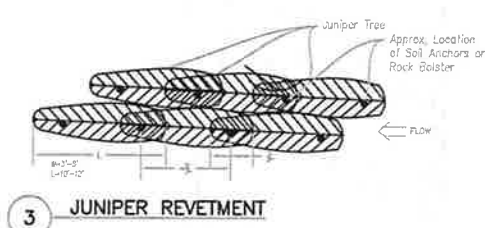

3 JUNIPER REVETMENT

Notes (3):
 Overlap juniper by $\frac{1}{4}$ to $\frac{1}{3}$ length in a shingle-like arrangement. Secure at overlap with three wraps of 12 gage wire or $\frac{1}{8}$ " cable and clamp securely. Anchor with a minimum of two sets of soil anchors per trunk as per specifications. Start at toe of bank. If additional rows are required, offset by not more than tree width. Press rows light together. Cable rows together with 12 gage wire or $\frac{1}{8}$ " cable and clamp.

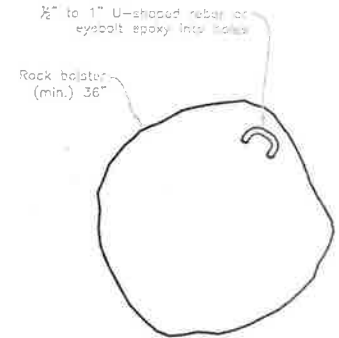

4 ROCK BOLSTER

Notes (2):
 Secure logs to rock bolsters at overlap with a minimum of three wraps of $\frac{1}{2}$ " stainless galvanized non-greased, wire mesh. Drill holes in rock bolsters with gas or pneumatic drill. The min. depth should be 4". Holes must be clean of all dust, debris, oil, and soap following drilling. Insert a U-shaped or eyebolt rebar into holes several times to disperse and completely mix epoxy and eliminate air pockets. Epoxy resin systems must meet the requirements of ASTM C881, Type IV Grade 3. Test strength of bond after minimum cure time recommended by the epoxy manufacturer.

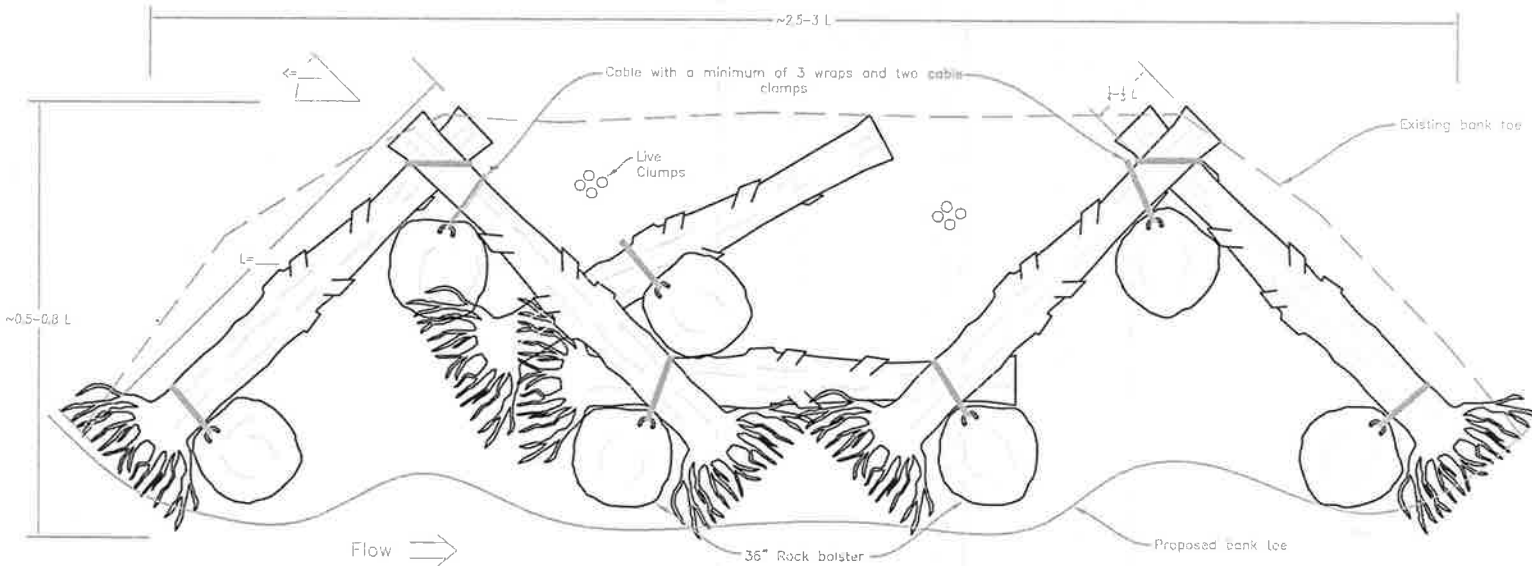

2 LOG REVETMENT



PREPARED BY: **CLARK'S ENGINEERING SOLUTIONS**
 10708 W. 51st Ave., Suite 100, Broomfield, CO 80020
 TEL: 303-472-4114
 FAX: 303-472-4104
 www.clarks-engineering.com

THESE DRAWINGS ARE FOR EXAMPLE PURPOSES ONLY. THEY ARE NOT INTENDED FOR CONSTRUCTION.

NO.	REVISIONS/DESCRIPTIONS	BY	DATE

LOG REVETMENT WITH ROCK BOLSTER
ECOLOGICAL DESIGN AND CONNECTIVITY PROJECT

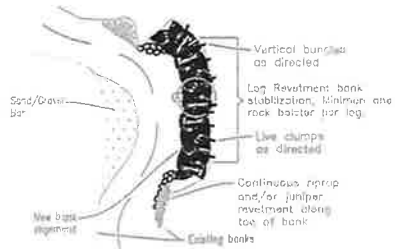

1 TREE REVETMENT FULL LAYOUT

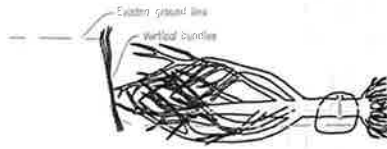

2 CROSS-SECTION

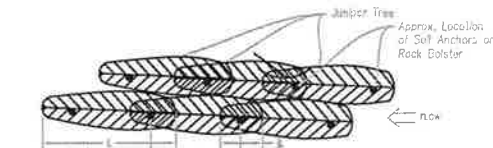

3 JUNIPER REVETMENT

Notes (3): Overlap juniper by $\frac{1}{4}$ to $\frac{1}{3}$ length in a shingle-like arrangement. Secure at overlap with three wraps of 12 gage wire or $\frac{1}{8}$ " cable and clamp securely. Anchor with a minimum of two sets of soil anchors per trunk as per specifications. Start at toe of bank, if additional rows are required, offset by not more than tree width. Press rows tight together. Cable rows together with 12 gage wire or $\frac{1}{8}$ " cable and clamp.

$\frac{1}{2}$ " to 1" U-shaped rebar or eyebolt epoxy into holes

Rock bolster (min.) 36"



4 ROCK BOLSTER

Notes (4): Secure to rock bolsters at overlap with a minimum of three wraps of $\frac{1}{8}$ - $\frac{1}{4}$ " diameter galvanized non-greased, wire rope. If constructing in or near water drill holes in rock bolsters with gas or pneumatic drill. Holes must be clean of all dust, debris, oil, and soap following drilling. Insert a U-shaped 1" rebar into holes several times to dispense and completely mix epoxy and eliminate air pockets. Epoxy resin systems shall meet the requirements of ASTM C851, Type IV Grade 3. Test strength of bond after minimum cure time recommended by the epoxy manufacturer.

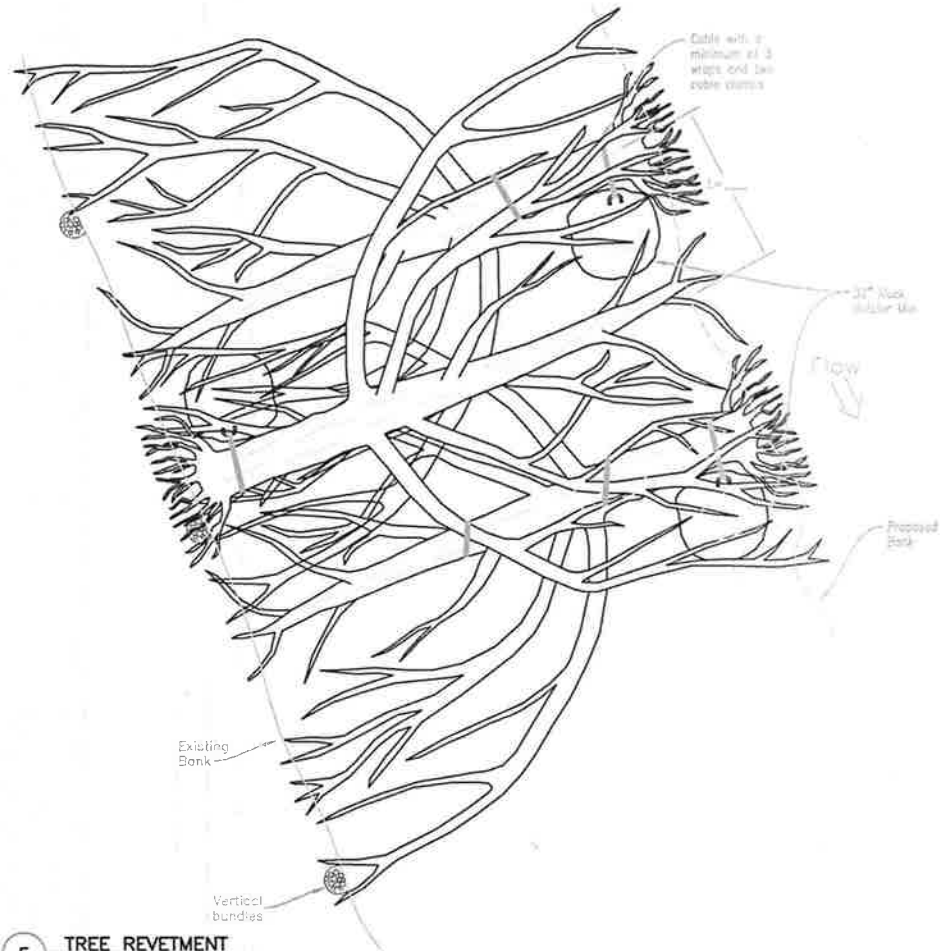

5 TREE REVETMENT

NO.	REVISION/DESCRIPTION	BY	DATE