



**Boulder County Purchasing**  
**1325 Pearl Street**  
**Boulder, CO 80302**  
[purchasing@bouldercounty.org](mailto:purchasing@bouldercounty.org)

**REQUEST FOR PROPOSAL**  
**COVER PAGE**

---

RFP Number:

**7322-22**

RFP Title:

**Allenspark Vault Toilet**

RFP Questions Due:

March 16, 2022 – 2:00 pm

Submittal Due Date:

March 30, 2022 – 2:00 pm

Email Address:

[purchasing@bouldercounty.org](mailto:purchasing@bouldercounty.org)

Documents included in this package:

Proposal Instructions  
Terms and Conditions  
Specifications  
Insurance and W-9 Requirements  
Submittal Checklist  
Evaluation Criteria  
Sustainability Questionnaire  
Signature Page  
Sample Contract  
Attachment A



**Boulder County Purchasing**  
**1325 Pearl Street**  
**Boulder, CO 80302**  
[purchasing@bouldercounty.org](mailto:purchasing@bouldercounty.org)

## **PROPOSAL INSTRUCTIONS**

---

### **1. Purpose/Background**

Boulder County Building Services (BCBS) is seeking proposals for a pre-engineered, concrete self-contained vault toilet with fresh water holding tank and waste vault. (No sanitary sewer connection). To be delivered at 14857 State Highway 7, Allenspark , CO 80510

### **2. Written Inquiries**

All inquiries regarding this RFP will be submitted via email to the Boulder County Purchasing Office at [purchasing@bouldercounty.org](mailto:purchasing@bouldercounty.org) on or before 2:00 p.m. **March 16, 2022**. A response from the county to all inquiries will be posted and sent via email no later than **March 23, 2022**.

**Do not contact any other county department or personnel with questions or for information regarding this solicitation.**

### **3. Submittal Instructions**

Submittals are due at the email box only, listed below, for time and date recording on or before **2:00 p.m. Mountain Time on March 30, 2022**.

**Please note that email responses to this solicitation are limited to a maximum of 50MB capacity.**

**NO ZIP FILES OR LINKS TO EXTERNAL SITES WILL BE ACCEPTED. THIS INCLUDES GOOGLE DOCS AND SIMILAR SITES. ALL SUBMITTALS MUST BE RECEIVED AS AN ATTACHMENT (E.G. PDF, WORD, EXCEL).**

**Electronic Submittals must be received in the email box listed below. Submittals sent to any other box will NOT be forwarded or accepted. This email box is only accessed on the**

**due date of your questions or proposals. Please use the Delivery Receipt option to verify receipt of your email. It is the sole responsibility of the proposer to ensure their documents are received before the deadline specified above. Boulder County does not accept responsibility under any circumstance for delayed or failed email or mailed submittals.**

**Email**      [purchasing@bouldercounty.org](mailto:purchasing@bouldercounty.org); identified as **RFP # 7322-22** in the subject line.

All RFPs must be received, and time and date recorded by authorized county staff by the above due date and time. Sole responsibility rests with the proposer to see that their RFP response is received on time at the stated location(s). Any responses received after due date and time will be returned to the proposer.

The Board of County Commissioners reserves the right to reject any and all responses, to waive any informalities or irregularities therein, and to accept the proposal that, in the opinion of the Board, is in the best interest of the Board and of the County of Boulder, State of Colorado.

Contractors and their employees, subcontractors, and agents must comply with all federal, state, and local laws, regulations, ordinances, orders, and codes, as well as Boulder County policies, guidelines, and protocols.

**Please be advised of the following contract term required for all Boulder County contracts effective 12/1/21:**

**COVID-19 Vaccine Requirement for Certain Contractors of County**

On September 28, 2021, the Boulder County Board of Commissioners adopted a COVID-19 vaccine requirement policy that applies to, as relevant here, all employees of independent contractors of the County that perform county work in a county facility. For purposes of this policy, “perform work in a county facility” means any employee of an independent contractor that routinely performs more than fifteen (15) hours per month of county work that takes place in or on a county facility/property. Under the County’s COVID-19 vaccine requirement policy, these individuals are required to receive a COVID-19 vaccine unless a reasonable accommodation based on medical reasons or due to a sincerely held religious belief is requested and approved. The policy requires that, by December 1, 2021, all individuals to which the policy applies must be fully vaccinated and submit proof of vaccination or have an approved reasonable accommodation in place. Therefore, beginning December 1, 2021, any employees of Contractor that perform county work in a county facility must be in compliance with the County’s vaccine requirement policy unless Contractor can show proof that it is in compliance with its own COVID-19 vaccine requirement policy or is required by local, state, or federal law or regulation to be compliant with a COVID-19 vaccine requirement policy.

**Americans with Disabilities Act (ADA)**: If you need special services provided for under the Americans with Disabilities Act, contact the ADA Coordinator or the Human Resources office at (303) 441-3525 at least 48 hours before the scheduled event.



**Boulder County Purchasing**  
**1325 Pearl Street**  
**Boulder, CO 80302**  
[purchasing@bouldercounty.org](mailto:purchasing@bouldercounty.org)

## **TERMS AND CONDITIONS**

---

1. Proposers are expected to examine the drawing, specifications, schedule of delivery, and all instructions. Failure to do so will be at the proposer's risk.
2. Each proposer will furnish the information required in the Request for Proposals.
3. The Contract/Purchase Order will be awarded to that responsible proposer whose submittal, conforming to the Request for Proposals, will be most advantageous to the County of Boulder, price and other factors considered.
4. The County of Boulder reserves the right to reject any or all proposals and to waive informalities and minor irregularities in proposals received, and to accept any portion of or all items proposed if deemed in the best interest of the County of Boulder to do so.
5. No submittal will be withdrawn for a period of thirty (30) days subsequent to the opening of proposals without the consent of the County Purchasing Agent or delegated representative.
6. A signed purchase order or contract furnished to the successful proposer results in a binding contract without further action by either party.
7. Late or unsigned proposals will not be accepted or considered. It is the responsibility of proposers to ensure that the proposal arrives at the purchasing email address prior to the time indicated in the "Request for Proposals."
8. The proposed price will be exclusive of any Federal or State taxes from which the County of Boulder is exempt by law.
9. Any interpretation, correction or change of the RFP documents will be made by Addendum. Interpretations, corrections and changes of the RFP documents made in any other manner will not be binding, and proposer will not rely upon such interpretations, corrections and changes. The County's Representative will not be responsible for oral

clarification.

10. Confidential/Proprietary Information: Proposals submitted in response to this “Request for Proposals” and any resulting contract are subject to the provisions of the Colorado Open Records Act, 24-72-201 et seq., C.R.S., as amended. Any restrictions on the use or inspection of material contained within the proposal or resulting contract will be clearly stated in the proposal and contract itself. Confidential/proprietary information must be readily identified, marked and separated/packaged from the rest of the proposal. Co-mingling of confidential/proprietary and other information is NOT acceptable. Proposals that do not properly identify confidential/proprietary information may be released in their entirety. Pricing totals contained in a proposal are not considered confidential.

**The Boulder County Attorney’s Office retains sole authority for determining whether the Colorado Open Records Act requires or permits Boulder County to disclose proposal or bid documents, or any information contained therein, pursuant to an open records request.**

11. Boulder County promotes the purchase/leasing of energy efficient materials and products with low toxicity levels when availability, quality and budget constraints allow. Proposers are expected whenever possible to provide products that earn the ENERGY STAR and meet the ENERGY STAR specifications for energy efficiency with power management features enabled. Proposers are encouraged to offer products and equipment with post-consumer recycled-content materials. Products should be packaged and delivered with a minimum amount of recycled packaging that adequately protects the product but is not excessive.
12. Pursuant to Colorado law (House Bill 1292), in any bidding process for public works in which a bid is received from a non-resident bidder who is from a state that provides a percentage bidding preference, a comparable percentage disadvantage will be applied to the bid of that bidder. Bidders may obtain additional information from the Department of Personnel’s website: <http://www.colorado.gov/dpa/>.



**Boulder County Purchasing**  
**1325 Pearl Street**  
**Boulder, CO 80302**  
[purchasing@bouldercounty.org](mailto:purchasing@bouldercounty.org)

## **SPECIFICATIONS**

---

### **Allenspark Vault Restroom Specifications:**

- Self-contained with fresh water holding tank and waste vault (Not connected to septic)
- Exterior Built from fire resistive materials to meet Boulder County requirements for Fire Zone 1
- Design criteria 175 mph wind and 55 lb/sqft snow
- Flushing toilet/Urinal and sink with running tempered water
- Mechanical room with man door
- Roof structure designed for future solar panels
- Aluminum frame on all windows
- Sealed concrete floor
- Covered porch with heavy timber construction
- Metal roof
- Wastewater and flush water indicators
- FRP board on walls
- Hand dryer: Xlerator1.1N-H, Brushed Stainless XL-SB
- Baseboard heaters: (2) Wall mounted 450W Cove Heater: C-4512 Comfort Cove Heater with (1) wall mount Honeywell P-8001 programable thermostat
- ADA compliant: Fixtures, Grab bars, appropriate door clearances, etc.
- Provide stamped engineered drawings for Permit submittal
- Include delivery to the site



**Boulder County Purchasing**  
**1325 Pearl Street**  
**Boulder, CO 80302**  
[purchasing@bouldercounty.org](mailto:purchasing@bouldercounty.org)

## **INSURANCE AND W-9 REQUIREMENTS**

---

### **INSURANCE REQUIREMENTS**

#### **i. Commercial General Liability**

Coverage should be provided on an Occurrence form, ISO CG0001 or equivalent. The policy shall be endorsed to include Additional Insured Owners, Lessees or Contractors endorsements CG 2038 (or equivalent), Designated Construction Project(s) General Aggregate Endorsement CG2503 (or equivalent) and Additional Insured Completed Operations for Owners, Lessees or Contractors CG 2037 (or equivalent). Minimum limits required of \$1,000,000 Each Occurrence, \$2,000,000 General Aggregate and \$2,000,000 Products/Completed Operations Aggregate. **The County requires the Products/Completed Operations coverage to be provided 3 years after completion of construction. An endorsement must be included with the certificate.**

#### **ii. Automobile Liability**

Bodily Injury and Property Damage for any owned, hired, and non-owned vehicles used in the performance of the Contract. Minimum limits \$1,000,000 Each Accident.

#### **iii. Workers' Compensation and Employer's Liability**

Workers' Compensation must be maintained with the statutory limits. Employer's Liability is required for minimum limits of \$100,000 Each Accident/\$500,000 Disease-Policy Limit/\$100,000 Disease-Each Employee.

#### **iv. Umbrella / Excess Insurance**

Umbrella/Excess Liability insurance in the amount \$3,000,000.00, following form.

#### **v. Professional Liability (Errors and Omissions)**

Professional liability coverage with minimum limits of \$1,000,000 Per Loss and \$1,000,000 Aggregate. Professional Liability provisions indemnifying for loss and expense resulting from errors, omission, mistakes or malpractice is acceptable and may be written on a claims-made basis. The contractor warrants that any retroactive date under the policy shall precede the effective date of this Contract; and that either continuous coverage will be maintained or an extended discovery period will be exercised for a period of two (2) years beginning at the time work under this Contract is complete

**Boulder County as Additional Insured: Boulder County shall be named as an additional insured for General Liability, Umbrella/Excess Liability, and Pollution Liability, as designated in this Contract. Additional insured shall be endorsed to the policy.**



**THE ADDITIONAL INSURED WORDING SHOULD BE AS FOLLOWS: *County of Boulder, State of Colorado, a body corporate and politic, is named as Additional Insureds.***

**\*In regards to General Liability, Umbrella/Excess Liability, and Pollution Liability:**

**If any or all of these coverages are required above, additional insured status will be required at the time a contract is executed.**

**Note that the above insurance amounts are the minimum required for this project. Proof of current insurance must be provided with your proposal in the form of a sample certificate. You are NOT required to include additional insured status until the time a contract is executed.**

**If you require a waiver of insurance requirements, you may request one in your response with an explanation.**

### **W-9 REQUIREMENT**

**Provide a copy of your business's W-9 with your proposal.**



**Boulder County Purchasing**  
**1325 Pearl Street**  
**Boulder, CO 80302**  
[purchasing@bouldercounty.org](mailto:purchasing@bouldercounty.org)

## SUBMITTAL SECTION

The proposer’s attention is especially called to the items listed below, which must be submitted in full as part of the PROPOSAL. Failure to submit any of the documents listed below as a part of your PROPOSAL, or failure to acknowledge any addendum in writing with your PROPOSAL, or submitting a proposal on any condition, limitation or provision not officially invited in this Request for Proposal (RFP) may be cause for rejection of the PROPOSAL.

**THIS CHECKLIST MUST BE SUBMITTED AS PART OF YOUR PROPOSAL PACKAGE:** Proposer will check each box indicating compliance:

INCLUDED	ITEM
	Name and Address of the Partners and Subcontractors if applicable
	A detailed project schedule with an all-inclusive total cost
	Information on the relevant experience of key personnel
	State your compliance with the Terms and Conditions in the Sample Contract contained in this RFP. Specifically list any deviations and provide justification for each deviation.
	Submit three references for similar projects your company has completed within the last three years and contact information. Boulder County will review all contractor evaluation forms from previous County projects.
	Insurance Certificate
	W-9
	Sustainability Questionnaire
	Signature Page
	Addendum Acknowledgement(s) (If Applicable)



**Boulder County Purchasing**  
**1325 Pearl Street**  
**Boulder, CO 80302**  
[purchasing@bouldercounty.org](mailto:purchasing@bouldercounty.org)

## **EVALUATION CRITERIA**

---

The proposals will be reviewed by a selection committee. The committee may request additional information from vendors or request interviews with one or more vendors. Final evaluation and selection may be based on, but not limited to, any or all of the following:

- Information presented in proposal, quality of product, qualifications and vendor experience, references.
- Ability of the vendor to provide timely products and services
- Total cost –or- Proposed pricing
- Sustainability Questionnaire score

**A scoring matrix with the order and priority of criteria to be used by the county in its evaluation and selection process is shown below:**

<b>Description</b>	<b>Points</b>
Information, Quality, References	30%
Ability to meet timeline	30%
Cost	30%
Sustainability Questionnaire	10%
<b>Total Possible</b>	<b>100%</b>



**Boulder County Purchasing**  
**1325 Pearl Street**  
**Boulder, CO 80302**  
[purchasing@bouldercounty.org](mailto:purchasing@bouldercounty.org)

## **SUSTAINABILITY QUESTIONNAIRE**

Company Name: \_\_\_\_\_ Date: \_\_\_\_\_

This questionnaire is applicable to firms that provide services as well as those that provide goods. Please answer the questions to the best of your ability.

1. What sustainability certifications does your business have? Please check the items that apply:

- B-Corp
- Green Business Bureau
- Fair Trade USA
- Green C Certification
- None
- Other - describe any other certifications your company has related to sustainability.

---

---

2. Does your company have a sustainability vision/commitment/values statement or policy?  
Please check the items that apply:

- Our sustainability statement/policy describes our company's sustainability initiatives.
- We have formed an oversight committee to ensure the success of our sustainability policy.
- Our sustainability statement/policy describes how our company explores opportunities to work with communities, governments and non-governmental and professional organizations to help articulate, teach and advance the principles of sustainability.
- We are currently in the process of developing a sustainability statement/policy consistent with a commitment to promote environmental, economic, and social sustainability.
- None

Other - Provide (or supply a link) your company's sustainability statement/policy.

---

---

---

3. What policies are in place to monitor and manage your supply chain regarding sustainability issues? Please select all that apply:

- We apply sustainability criteria when making purchasing decisions.
- We partner with suppliers who share in our sustainability commitment and/or work with them to reduce the impact to the environment of our resource needs as well as improve worker conditions.
- We purchase "green" (i.e. recyclable, reusable, non-toxic, compostable, fair trade and made from 100% post-consumer recycled materials) supplies, products, and materials.
- We specify locally manufactured products in procuring goods.
- We specify products that use the Electronic Products Environmental Assessment Tool (EPEAT) standards in procuring goods.
- None.
- Other – describe other ways your company monitors and manages your supply chain concerning environmental issues.

---

---

---

4. Does your company promote sustainable transportation in its operations? Please select all that apply:

- We own, rent, or lease electric fleet vehicles.
- We own, rent, or lease hybrid or natural gas fueled fleet vehicles.
- We encourage carpooling, public transportation, and using other alternative modes of transportation.
- We subsidize public transportation for employees.
- We have an established Green Transportation Plan
- We are developing a Green Transportation Plan
- We offer flexible hours, telecommuting, or a compressed work week.
- We utilize teleconference, video conference, WebEx or GoTo Meetings (or other similar conferencing services).
- None
- Other – describe other ways your company promotes sustainable transportation. If applicable, use this space to describe your company's Green Transportation Plan (whether existing or in development).

---

---

---

5. What does your company do to minimize the environmental impacts associated with shipping? Please check the items that apply:

- We have established company policies and procedures that minimize the need for shipping in the first place
- We combine deliveries with customer visits.
- We consolidate deliveries.
- We use bike couriers for local delivery.
- We utilize electronic communications and electronic transfer of documents, such as e-mail, fax and Portable Document Format (PDF).
- We specify products that can be purchased locally within a 500-mile radius of the delivery location in procuring goods.
- We are currently evaluating what the company can do to minimize the environmental impacts associated with shipping (must describe below; no additional points awarded for providing this description).
- Our packaging/shipping materials are reusable.
- Our packaging/shipping materials are made from 100% post-consumer recycled materials.
- N/A
- Other – describe what your company does to minimize the environmental costs associated with shipping. If applicable, use this space to provide required description(s).

---

---

---

6. Has your company ever been cited for non-compliance of any law, regulation, ordinance, code, rule, standard, or policy regarding an environmental or safety issue? Please check the item that applies:

- No, my company HAS NOT been cited for non-compliance regarding an environmental or safety issue.
- Yes, my company HAS been cited for non-compliance of an environmental or safety issue.
- N/A State the reason, date and outcome of the citation:

---

---

---

7. What programs do you have, either in place or currently being planned, to promote resource efficiency? Examples include energy or waste audit programs. Please check the items that apply:

- We have an established zero waste program.
- We utilize a facilities energy management system.
- We have adopted a climate action plan.
- We have a water conservation program.

- We have formed a sustainability committee to identify sustainable solutions for our company.
- We are a member of various sustainability organizations.
- We are recognized by peers and environmental organizations for providing leadership in Sustainability.
- None
- Other - what other programs do you have in place or planned for promoting resource Efficiency?

---



---



---

8. If your business’s proposal involves the provision of a product, does the manufacturer of the product, whether your business or an outside entity, have a sustainability policy statement? Please check the item that applies:

- No, the manufacturer of the product that I am proposing DOES NOT have a sustainability policy statement.
- Yes, the manufacturer of the product that I am proposing HAS a sustainability policy statement.
- Not applicable.

Provide Sustainability Policy Statement:

---



---



---

9. If your business’s proposal involves the provision of a product, has the manufacturer of the product, whether your business or an outside entity, ever been cited for non-compliance of any law, regulation, ordinance, code, rule, standard, or policy regarding an environmental or safety issue? Please check the item that applies:

- No, the manufacturer of the product that I am proposing HAS NOT been cited for noncompliance regarding an environmental or safety issue.
- Yes, the manufacturer of the product that I am proposing HAS been cited for noncompliance regarding an environmental or safety issue.
- Not applicable.

Provide reason, date and outcome of the citation:

---



---



---

10. If your business’s bid/proposal involves the provision of a product, has an environmental life-cycle analysis of the product that you are proposing been conducted by a certified testing

organization, such as Green Seal, Energy Star, and Cradle to Cradle? Please check the item that applies.

- No, an environmental life-cycle analysis of the product that I am bidding/proposing HAS NOT been conducted by a certified testing organization, such as Green Seal.
- Yes, an environmental life-cycle analysis of the product that I am bidding/proposing HAS been conducted by a certified testing organization, such as Green Seal.
- Not applicable.

Provide certification:

---

---

---





**Boulder County Purchasing**  
**1325 Pearl Street**  
**Boulder, CO 80302**  
[purchasing@bouldercounty.org](mailto:purchasing@bouldercounty.org)

**SIGNATURE PAGE**

Contact Information	Response
Company Name including DBA	
List Type of Organization (Corporation, Partnership, etc.)	
Name, Title, and Email Address of Person Authorized to Contract with Boulder County	
Company Address	
Company Phone Number	
Company Website	

**By signing below, I certify that:**

- I am authorized to bid on my company's behalf.
- I am not currently an employee of Boulder County.
- None of my employees or agents is currently an employee of Boulder County.
- I am not related to any Boulder County employee or Elected Official.
- (Sole Proprietorships Only) I am not a Public Employees' Retirement Association (PERA) retiree.

\_\_\_\_\_  
**Signature of Person Authorized to Bid on  
 Company's Behalf**

\_\_\_\_\_  
**Date**

Note: If you cannot certify the above statements, please explain in a statement of explanation.

# **BOULDER COUNTY SAMPLE CONTRACT**

THIS CONTRACT ("Contract") is entered into by and between the Board of County Commissioners on behalf of the County of Boulder, State of Colorado, a body corporate and politic, for the benefit of the [Public Works] ("County") and [Supplier] ("Contractor"). County and Contractor are each a "Party," and collectively the "Parties."

In consideration of the mutual covenants contained in this Contract, the receipt and sufficiency of which is hereby acknowledged, the Parties agree as follows:

1. **Incorporation into Contract:** The **Details Summary** is incorporated into this Contract. The **Contract Documents** are incorporated into this Contract by reference, except to the extent that the Proposal, if any is incorporated, contains any obligations placed upon County and not otherwise contained in this Contract.
2. **Work to be Performed:** Contractor will provide all labor and equipment and do all tasks necessary and incidental to performing the work as described in the **Details Summary** and **Contract Documents** (the "Work"). Contractor will perform the Work (a) in a good and workmanlike manner, (b) at its own cost and expense, (c) in accordance with recognized industry standards of care, skill and diligence for the type of work being performed, and (d) in strict accordance with the Contract.
3. **Term of Contract:** The **Contract Term** begins on the **Start Date** and expires on the **Expiration Date**, unless terminated sooner. All the Work must be performed during the **Contract Term**.
4. **Payment for Work Performed:** In consideration of the Work performed by Contractor, and subject to conditions contained in this Contract, County will pay an amount not to exceed the **Contract Amount** to Contractor in accordance with the **Contract Documents**.
5. **Invoicing:** Contractor will promptly provide a copy of its Form W-9 and invoice template to County upon request. Contractor must submit an invoice to the County by the fifteenth (15th) day of the month for completion of any Work performed in the prior calendar month. All invoices submitted require the following components: Contractor's name and address (submitted W-9 address must match remit address), detailed description of services, dates of services, itemization of labor and materials costs, "Bill to: Boulder County" language, payment remittance address, payer, name and address, date of invoice, unique invoice number, and total amount due. Contractor must send all completed invoices to the **Invoice Contact** in the **Details Summary**. County may require delivery of invoices by email. Failure to submit invoices in a timely manner and in accordance with the terms of this Contract may cause a delay in payment. County may recoup any damages incurred because of Contractor's failure to submit invoices pursuant to the terms of this paragraph. County's acceptance or payment of an invoice will not constitute acceptance of any Work performed under this Contract.
6. **Extra Time to Complete the Work (Additional Time only):** If Contractor cannot complete the Work by the **Expiration Date**, Contractor may request extra time to complete the Work. County, in its sole discretion, may grant Contractor additional time to complete the Work by sending a written notice of extension to Contractor. An extension of time to complete the Work does not entitle Contractor to additional compensation from County.
7. **Extension of Contract Term (Additional Time and Work):** Upon mutual agreement of the Parties, this Contract may be extended until the **Final End Date**. During any extended **Contract Term**, the terms of this Contract will remain in full force and effect, unless otherwise amended in writing by the Parties. Where the Contractor will provide additional services for additional compensation beyond the initial **Contract Amount**, the Parties must execute a written amendment before the then-current **Expiration Date**. If necessary, the written amendment will incorporate an updated Scope of Work and updated Fee Schedule as exhibits. Contractor must provide a current Certificate of Insurance to the County that complies with the **Insurance Requirements** of this Contract, if any, prior to any extended **Contract Term**.
8. **Schedule of Work:** County may designate the hours (on a daily or weekly basis) during which Contractor may perform the Work, strictly for the purposes of minimizing inconvenience to the County and interference with County operations. Contractor will otherwise set its own work schedule.

9. **Indemnity:** Contractor will be liable for any damages to persons or property caused by or arising out of the actions, obligations, or omissions of Contractor, its employees, agents, representatives or other persons acting under Contractor's direction or control in performing or failing to perform the Work under this Contract. Contractor will indemnify and hold harmless County, its elected officials and appointed department heads, and its employees, agents and representatives (the "indemnified parties"), from any and all liability, claims, demands, actions, damages, losses, judgments, costs or expenses, including attorneys' fees, which may be made or brought or which may result against any of the indemnified parties as a result or on account of the actions or omissions of Contractor, its employees, agents or representatives, or other persons acting under Contractor's direction or control. This indemnification obligation will extend to claims based on Contractor's unauthorized use or disclosure of confidential information and intellectual property infringement. County will not be obligated to indemnify or defend Contractor under any circumstances. Contractor's obligations under this provision shall survive expiration or termination of this Contract. Nothing contained in this Contract or the **Contract Documents** is intended to limit or restrict the indemnification rights or obligations of any Party under this provision, or damages available for breaches of the obligations herein.

10. **Nondiscrimination:** Contractor will comply with the Colorado Anti-Discrimination Act, C.R.S. § 24-34-401, et seq., as amended, and all applicable local, State and Federal laws concerning discrimination and unfair employment practices. County prohibits unlawful discrimination on the basis of race, color, religion, gender, gender identity, national origin, age 40 and over, disability, socio-economic status, sexual orientation, genetic information, or any other status protected by applicable Federal, State or local law. Contractor must require that its subcontractors, if any, similarly comply with all applicable laws concerning discrimination and unfair employment practices.

11. **Information and Reports:** Contractor will provide to authorized County, State, and Federal government representatives all information and reports that may be required for any purpose authorized by law. Contractor will permit access to such representatives to Contractor's facilities, books, records, accounts, and any other relevant sources of information. Where information required by a representative is in the exclusive possession of a person or entity other than Contractor, Contractor must so certify to the County and explain what efforts it has made to obtain the information.

12. **Independent Contractor:** Contractor is an independent contractor for all purposes in performing the Work. None of Contractor, its agents, personnel or subcontractors are employees of the County for any purpose, including the Federal Insurance Contribution Act, the Social Security Act, the Federal Unemployment Tax Act, the provisions of the Internal Revenue Code, the Colorado Workers' Compensation Act, the Colorado Unemployment Insurance Act, and the Public Employees Retirement Association. Accordingly, County will not withhold or pay any income tax, payroll tax, or retirement contribution of any kind on behalf of Contractor or Contractor's employees. As an independent contractor, Contractor is responsible for employing and directing such personnel and agents as it requires to perform the Work. Contractor will exercise complete authority over its personnel and agents and will be fully responsible for their actions.

13. **Termination**

a. **Breach:** Either Party's failure to perform any of its material obligations under this Contract, in whole or in part or in a timely or satisfactory manner, will be a breach. The institution of proceedings under any bankruptcy, insolvency, reorganization or similar law, by or against Contractor, or the appointment of a receiver or similar officer for Contractor or any of its property, which is not vacated or fully stayed within thirty (30) days after the institution of such proceeding, will also constitute a breach. In the event of a breach, the non-breaching Party may provide written notice of the breach to the other Party. If the breaching Party does not cure the breach, at its sole expense, as reasonably determined by the non-breaching Party in its sole discretion, within thirty (30) days after delivery of notice, the non-breaching Party may exercise any of its remedies provided under this Contract or at law, including immediate termination of this Contract.

b. **Non-Appropriation:** The other provisions of this Contract notwithstanding, County is prohibited by law from making commitments beyond the current fiscal year. Payment to Contractor beyond the current fiscal year is contingent on the appropriation and continuing availability of funding in any subsequent year. County has reason to believe that sufficient funds will be available for the full **Contract Term**. Where, however, funds are not allocated for any fiscal period beyond the current fiscal year, County may terminate this Contract without penalty by providing seven (7) days' written notice to Contractor.

c. Convenience: In addition to any other right to terminate under this Section 13, County may terminate this Contract, in whole or in part, for any or no reason, upon seven (7) days' advance written notice to Contractor.

14. Contractor Obligations upon Termination or Expiration: By the **Expiration Date** or effective date of termination, if earlier, Contractor must (1) remove from County property all of its personnel, equipment, supplies, trash and any hazards created by Contractor, (2) protect any serviceable materials belonging to the County, and (3) take any other action necessary to leave a safe and healthful worksite. Any items remaining on County property after the Expiration Date or the effective date of termination, if earlier, will be deemed abandoned by Contractor.

15. Payable Costs in Event of Early Termination: If County terminates this Contract before the **Expiration Date**, Contractor's payments (and any damages associated with any lawsuit brought by Contractor) are limited to only (1) payment for Work satisfactorily executed and fully and finally completed, as determined by County in its sole discretion, prior to delivery of the notice to terminate, and (2) the reasonable and actual costs Contractor incurred in connection with performing the Work prior to delivery of the notice to terminate. Contractor explicitly waives all claims it may have against the County for any other compensation, such as anticipatory profits or any other consequential, special, incidental, punitive or indirect damages.

16. Remedies for Non-Performance: If Contractor fails to perform any of its obligations under this Contract, County may, at its sole discretion, exercise one or more of the following remedies (in addition to any other remedies provided by law or in this Contract), which shall survive expiration or termination of this Contract:

a. Suspend Performance: County may require that Contractor suspend performance of all or any portion of the Work pending necessary corrective action specified by the County and without entitling Contractor to an increase in compensation or extension of the performance schedule. Contractor must promptly stop performance and incurring costs upon delivery of a notice of suspension by the County.

b. Withhold Payment Pending Corrections: County may permit Contractor to correct any rejected Work at the County's discretion. Upon County's request, Contractor must correct rejected work at Contractor's sole expense within the time frame established by the County. Upon full and final completion of the corrections satisfactory to the County, County will remit payment to Contractor.

c. Deny Payment: County may deny payment for any Work that does not comply with the requirements of the Contract or that Contractor otherwise fails to provide or fully and finally complete, as determined by the County in its sole discretion. Upon County request, Contractor will promptly refund any amounts prepaid by the County with respect to such non-compliant Work.

d. Removal: Upon County's request, Contractor will remove any of its employees or agents from performance of the Work, if County, in its sole discretion, deems any such person to be incompetent, careless, unsuitable, or otherwise unacceptable.

17. Binding Arbitration Prohibited: County does not agree to binding arbitration by any extra-judicial body or person.

18. Conflicts of Interest: Contractor may not engage in any business or personal activities or practices or maintain any relationships that conflict in any way with the full performance of Contractor's obligations.

19. Notices: All notices provided under this Contract must be in writing and sent by Certified U.S. Mail (Return Receipt Requested), electronic mail, or hand-delivery to the other Party's **Contact** at the address specified in the **Details Summary**. For certified mailings, notice periods will begin to run on the day after the postmarked date of mailing. For electronic mail or hand-delivery, notice periods will begin to run on the date of delivery.

20. Statutory Requirements: This Contract is subject to all statutory requirements that are or may become applicable to counties or political subdivisions of the State of Colorado generally, including but not limited to: C.R.S. § 38-26-107, which requires withholding funds where the County receives a claim for payment from a supplier or

subcontractor of Contractor upon notice of final settlement (required for public works contracts that exceed \$150,000); C.R.S. § 8-17-101 et seq.; C.R.S. § 18-8-301, et seq.; and C.R.S. § 18-8-401, et seq.

21. Public Contracts for Services (C.R.S. §§ 8-17.5-101, et seq.): *The phrase “unauthorized worker” as used in this provision shall have the same and intended meaning as “illegal alien” as such phrase is used in C.R.S. §§ 8-17.5-101, et seq.* Contractor hereby certifies, warrants, and agrees that it does not knowingly employ or contract with an unauthorized worker who will perform work under this Contract and further certifies that it will confirm the employment eligibility of all employees who are newly hired for employment to perform work under this Contract by participating in the E-Verify Program established under Pub. L. 104-28 or the department verification program established under C.R.S. § 8-17.5-102(5)(c). Contractor (i) shall not knowingly employ or contract with an unauthorized worker to perform work under this Contract; (ii) shall not enter into a contract with a subcontractor that fails to certify to the contractor that the subcontractor shall not knowingly employ or contract with an unauthorized worker to perform work under this Contract; (iii) has confirmed the employment eligibility of all employees who are newly hired for employment to perform work under this Contract through participation in the E-Verify program or department program; (iv) is prohibited from using either the E-Verify program or department program procedures to undertake preemployment screening of job applicants while this Contract is being performed; and (v) shall comply with any reasonable request by the department made in the course of an investigation that the Colorado Department of Labor and Employment is undertaking pursuant to the authority established in C.R.S. § 8-17.5-102(5). If Contractor obtains actual knowledge that a subcontractor performing work under this Contract knowingly employs or contracts with an unauthorized worker, Contractor shall (a) notify the subcontractor and County within three (3) days that Contractor has actual knowledge that subcontractor is employing or contracting with an unauthorized worker; and (b) terminate the subcontract if, within three (3) days of receiving notice hereunder, subcontractor does not stop employing or contracting with the unauthorized worker; except that Contractor shall not terminate the contract with the subcontractor if during such three (3) days the subcontractor provides information to establish that the subcontractor has not knowingly employed or contracted with an unauthorized worker. Contractor’s violation of this provision will constitute a material breach of this Contract, entitling the County to terminate the contract for breach. If this Contract is so terminated, Contractor shall be liable for actual and consequential damages to the County.

22. Entire Agreement/Binding Effect/Amendments: This Contract represents the complete agreement between the Parties and is fully binding upon them and their successors, heirs, and assigns, if any. This Contract terminates any prior agreements, whether written or oral in whole or in part, between the Parties relating to the Work. This Contract may be amended only by a written agreement signed by both Parties.

23. Assignment/Subcontractors: This Contract may not be assigned or subcontracted by Contractor without the prior written consent of the County. If Contractor subcontracts any of its obligations under this Contract, Contractor will remain liable to the County for those obligations and will also be responsible for subcontractor’s performance under, and compliance with, this Contract.

24. Governing Law/Venue: The laws of the State of Colorado govern the construction, interpretation, performance, and enforcement of this Contract. Any claim relating to this Contract or breach thereof may only be brought exclusively in the Courts of the 20<sup>th</sup> Judicial District of the State of Colorado and the applicable Colorado Appellate Courts.

25. Breach: The failure of either Party to exercise any of its rights under this Contract will not be deemed to be a waiver of such rights or a waiver of any breach of the Contract. All remedies available to a Party in this Contract are cumulative and in addition to every other remedy provided by law.

26. Severability: If any provision of this Contract becomes inoperable for any reason but the fundamental terms and conditions continue to be legal and enforceable, then the remainder of the Contract will continue to be operative and binding on the Parties.

27. Third-Party Beneficiary: Enforcement of the terms and conditions and all rights and obligations of this Contract are reserved to the Parties. Any other person receiving services or benefits under this Contract is an incidental beneficiary only and has no rights under this Contract. Notwithstanding, where the beneficiary **Department** is led by an Elected Official, such Elected Official shall be considered a third-party beneficiary.

28. Colorado Open Records Act: County may disclose any records that are subject to public release under the Colorado Open Records Act, C.R.S. § 24-72-200.1, et seq.
29. Conflict of Provisions: If there is any conflict between the terms of the main body of this Contract and the terms of any of the **Contract Documents**, the terms of the main body of the Contract will control.
30. Governmental Immunity: Nothing in this Contract shall be construed in any way to be a waiver of the County's immunity protection under the Colorado Governmental Immunity Act, C.R.S. § 24-10-101, et seq., as amended.
31. Representations and Warranties: Contractor represents and warrants the following:
- a. Execution of this Contract and performance thereof is within Contractor's duly authorized powers;
  - b. The individual executing this Contract is authorized to do so by Contractor;
  - c. Contractor is authorized to do business in the State of Colorado and is properly licensed by all necessary governmental and public and quasi-public authorities having jurisdiction over the Work and the Contractor; and
  - d. Contractor and its subcontractors, if any, are financially solvent, able to pay all debts as they mature, and have sufficient working capital to complete the Work and perform all obligations under the Contract.
32. Legal Compliance: Contractor assumes full responsibility for obtaining and maintaining any permits and licenses required to perform the Work. Contractor is solely responsible for ensuring that its performance under this Contract and the Work itself will comply with all Federal, State, and local laws, regulations, ordinances and codes. County approval of the Work or any aspect of Contractor's performance, such as plans, designs, or other Contractor-drafted documents, shall not be interpreted to mean that Contractor has satisfied its obligations under this Section.
33. Litigation Reporting: Contractor is not currently involved in any action before a court or other administrative decision-making body that could affect Contractor's ability to perform the Work. Contractor will promptly notify the County if Contractor is served with a pleading or other document in connection with any such action.
34. Tax Exemption: County is exempt from payment of Federal, State, and local government taxes. Contractor shall collect no tax from the County, and the County shall not be liable to pay any taxes imposed on Contractor. County shall provide its tax exemption status information to Contractor upon request.
35. Delegation of Authority: The Parties acknowledge that the Board of County Commissioners has delegated authority to the Department Head or Elected Official that leads the beneficiary **Department** and their designees to act on behalf of the County under the terms of this Contract, including but not limited to the authority to terminate this Contract.
36. Ownership of Work Product: All work product, property, data, documentation, information or materials conceived, discovered, developed or created by Contractor pursuant to this Contract ("Work Product") will be owned exclusively by the County. To the extent possible, any Work Product will be deemed to be a work made for hire. Contractor unconditionally and irrevocably transfers and assigns to the County all right, title and interest in and to any Work Product.
37. Publicity Releases: Contractor will not refer to this Contract or the County in commercial advertising without prior written consent of the County. This provision shall survive expiration or termination of this Contract.
38. Execution by Counterparts; Electronic Signatures: This Contract may be executed in multiple counterparts, each of which will be deemed an original, but all of which will constitute one agreement. The Parties approve the use of electronic signatures, governed by the Uniform Electronic Transactions Act, C.R.S. §§ 24 71.3 101 to 121. The Parties will not deny the legal effect or enforceability of this Contract solely because it is in electronic form or because an electronic record was used in its creation. The Parties will not object to the admissibility of this Contract in the form of electronic record, or paper copy of an electronic document, or paper copy of a document bearing an electronic signature, because it is not in its original form or is not an original.
39. Limitation on Public Statements and Lobbying Activity: During the term of this Contract, Contractor may receive from the County its confidential data, work product, or other privileged or confidential information that is

protected by law. To maintain the fact and appearance of absolute objectivity, Contractor shall not, without the prior written consent of the County, which shall not be unreasonably withheld, do any of the following: (a) disclose information obtained because of this contractual relationship to any third party; (b) lobby any State or Federal agency on any pending matter while this Contract is effective; or (c) make any public statements or appear at any time to give testimony at any public meeting on the subject matters regarding which Contractor is or was retained by the County. County may set reasonable conditions on any disclosure authorized by the County under this provision. Notwithstanding, Contractor may make disclosures as required by law, and to law enforcement officials in connection with any criminal justice investigation.

40. Sustainability: County encourages Contractor to consider the procurement and use of environmentally preferable products and services while performing services under this Contract. “Environmentally preferable purchasing” means making purchasing choices for products and services that have a lesser or reduced adverse effect on human health and the environment when compared with competing products and services that serve the same purpose. Environmentally preferable purchasing is consistent with the County’s commitment to protecting our air, water, soil, and climate for current and future generations. County encourages Contractor to incorporate the following actions into Contractor’s performance of the Work: environmentally preferable supplies and services; conservation of water; efficient energy use; waste prevention; reuse and recycle construction and de-construction materials in a manner that maximizes reuse of materials; sustainable transportation choices, including consideration to business communication software such as Skype alternative to air travel and public transit or carpooling for in-person meetings; pollution prevention; low toxicity for public health & safety; and reduced emissions to address climate change.

41. Limitation of Liability: COUNTY SHALL NOT BE LIABLE TO CONTRACTOR FOR ANY SPECIAL, CONSEQUENTIAL, INCIDENTAL, PUNITIVE, OR INDIRECT DAMAGES ARISING FROM OR RELATING TO THIS CONTRACT, REGARDLESS OF ANY NOTICE OF THE POSSIBILITY OF SUCH DAMAGES. COUNTY’S AGGREGATE LIABILITY, IF ANY, ARISING FROM OR RELATED TO THIS CONTRACT, WHETHER IN CONTRACT, OR IN TORT, OR OTHERWISE, IS LIMITED TO, AND SHALL NOT EXCEED, THE AMOUNTS PAID OR PAYABLE HEREUNDER BY COUNTY TO CONTRACTOR. ANY CONTRACTUAL LANGUAGE LIMITING CONTRACTOR’S LIABILITY SHALL BE VOID.

42. Legal Interpretation. Each Party recognizes that this Contract is legally binding and acknowledges that it has had the opportunity to consult with legal counsel of its choice about this Contract. The rule of construction providing that any ambiguities are resolved against the drafting Party will not apply in interpreting the terms of this Contract.

43. No Suspension or Debarment: Contractor certifies, and warrants for the Contract Term, that neither it nor its principals nor any of its subcontractors are debarred, suspended, proposed for debarment, declared ineligible, or voluntarily excluded from participation in this Contract by any Federal or State department or agency. Contractor shall comply, and shall require its subcontractors to comply, with subpart C of 2 C.F.R. § 180.

44. COVID-19 Vaccine Requirement for Certain Contractors/Vendors/Subrecipients of the County: On September 28, 2021, the Boulder County Board of Commissioners adopted a COVID-19 vaccine requirement policy that applies to, as relevant here, all employees of independent contractors of the county that perform county work in a county facility. For purposes of this policy, “perform work in a county facility” means any employee of an independent contractor that routinely performs more than fifteen (15) hours per month of county work that takes place in or on a county facility/property. Under the county’s COVID-19 vaccine requirement policy, these individuals are required to receive a COVID-19 vaccine unless a reasonable accommodation based on medical reasons or due to a sincerely held religious belief is requested and approved. The policy requires that, by December 1, 2021, all individuals to which the policy applies must be fully vaccinated and submit proof of vaccination or have an approved reasonable accommodation in place. Therefore, beginning December 1, 2021, any employees of Contractor/Vendor/Subrecipient that perform county work in a county facility must be in compliance with the County’s vaccine requirement policy unless Contractor/Vendor/Subrecipient can show proof that it is in compliance with its own COVID-19 vaccine requirement policy or is required by local, state, or federal law or regulation to be compliant with a COVID-19 vaccine requirement policy.

45. Insurance: Prior to commencing the Work, Contractor will provide a Certificate of Insurance to the County demonstrating adequate insurance coverage as required by this Section. All policies evidencing coverage required by the Contract will be issued by insurance companies satisfactory to the County. Contractor will forward Certificates of Insurance directly to the **County Department** and **Contact** listed in the **Details Summary**.

a. Boulder County as Additional Insured: Boulder County shall be named as an additional insured for General Liability, Umbrella/Excess Liability, and Pollution Liability, as designated in this Contract. Additional insured shall be endorsed to the policy.

**THE ADDITIONAL INSURED WORDING SHOULD BE AS FOLLOWS:** *County of Boulder, State of Colorado, a body corporate and politic, is named as Additional Insured.*

b. Notice of Cancellation: Each insurance policy required by this Contract shall provide the required coverage and shall not be suspended, voided or canceled except after thirty (30) days' prior written notice has been given to the County except when cancellation is for non-payment of premium, then ten (10) days' prior notice may be given. If any insurance company refuses to provide the required notice, Contractor or its insurance broker shall notify the County any cancellation, suspension, or nonrenewal of any insurance policy within seven (7) days of receipt of insurers' notification to that effect.

c. Insurance Obligations of County: County is not required to maintain or procure any insurance coverage beyond the coverage maintained by the County in its standard course of business. Any insurance obligations placed on the County in any of the **Contract Documents** shall be null and void.

d. Deductible: Any and all deductibles contained in any insurance policy shall be assumed by and at the sole risk of Contractor.

e. Primacy of Coverage: Coverage required of Contractor and its subcontractors, if any, shall be primary over any insurance or self-insurance program carried by the County.

f. Subrogation Waiver: All insurance policies in any way related to this Contract secured or maintained by Contractor as required herein shall include clauses stating that each carrier shall waive all rights of recovery, under subrogation or otherwise, against County, its organizations, officers, agents, employees, and volunteers.

g. Requirements: For the entire duration of this Contract including any extended or renewed terms, and longer as may be required by this Contract, Contractor shall procure and maintain at its own expense, and without cost to the County, the following kinds and minimum amounts of insurance to insure the liability risks that Contractor has assumed under this Contract:

i. **Commercial General Liability**

**Delete Instruction: Non-Construction contracts use the following language:**

This coverage should be provided on an Occurrence Form, ISO CG001 or equivalent, with Minimum limits of \$1,000,000 Each Occurrence, \$2,000,000 General Aggregate and \$2,000,000 Products Completed Operations Aggregate.

**Delete Instruction: Construction Contracts only – include the following paragraph:**

Coverage should be provided on an Occurrence form, ISO CG0001 or equivalent. The policy shall be endorsed to include Additional Insured Owners, Lessees or Contractors endorsements CG 2038 (or equivalent), Designated Construction Project(s) General Aggregate Endorsement CG2503 (or equivalent) and Additional Insured Completed Operations for Owners, Lessees or Contractors CG 2037 (or equivalent). Minimum limits required of \$1,000,000 Each Occurrence, \$2,000,000 General Aggregate and \$2,000,000 Products/Completed Operations Aggregate. The County requires the Products/Completed Operations coverage to be provided 3 years after completion of construction. An endorsement must be included with the certificate.

ii. **Automobile Liability**

Bodily Injury and Property Damage for any owned, hired, and non-owned vehicles used in the performance of the Contract. Minimum limits \$1,000,000 Each Accident.



**Delete Instruction: This coverage may not be required if Contractor is not using a vehicle as part of its performance under the contract. Contact Risk Management with any questions.**

iii. **Workers' Compensation and Employer's Liability**

Workers' Compensation must be maintained with the statutory limits. Employer's Liability is required for minimum limits of \$100,000 Each Accident/\$500,000 Disease-Policy Limit/\$100,000 Disease-Each Employee.

**Delete Instruction: This coverage may not be required if contractor is not mandated under State law to maintain this coverage. A waiver is available on the contracts routing website.**

iv. **Umbrella / Excess Insurance**

Umbrella/Excess Liability insurance in the amount \$[X],000,000.00, following form.

**Delete Instruction: This insurance is a broad, high-limit policy, which acts more than the underlying primary insurance policy. This coverage is designed to provide additional liability limits beyond the primary insurance limits and is triggered upon the underlying limits becoming exhausted. Umbrella / Excess insurance is most commonly required when an exposure to the County could potentially create liabilities in excess of the basic insurance limits. The most common limits for these policies range from \$2,000,000 to \$5,000,000.**

**Delete Instruction: Please consult with Risk Management if you feel this coverage should be required.**

**Delete Instruction: IN ADDITION TO THE ABOVE, ONE OR MORE OF THE FOLLOWING FOUR (4) INSURANCE COVERAGES MAY BE REQUIRED. CONTACT RISK MANAGEMENT IF YOU HAVE QUESTIONS ABOUT WHICH INSURANCE COVERAGE TO INCLUDE. DELETE THIS INSTRUCTION (AND ANY INAPPLICABLE INSURANCE PARAGRAPHS) WHEN FINALIZING THE CONTRACT:**

v. **Professional Liability (Errors and Omissions)**

**Delete Instruction: All contractors required to be professionally certified by the State of Colorado (i.e., architects, engineers, doctors, nurses, etc.) and/or any consultants whose errors in judgment, planning, design, etc. could result in economic loss to the County must provide proof of professional liability coverage. This also applies to anyone managing or overseeing construction.**

Professional liability coverage with minimum limits of \$1,000,000 Per Loss and \$1,000,000 Aggregate. Professional Liability provisions indemnifying for loss and expense resulting from errors, omission, mistakes or malpractice is acceptable and may be written on a claims-made basis. The contractor warrants that any retroactive date under the policy shall precede the effective date of this Contract; and that either continuous coverage will be maintained or an extended discovery period will be exercised for a period of two (2) years beginning at the time work under this Contract is completed.

vi. **Pollution Liability**

**Delete Instruction: This coverage is required whenever work under the contract involves pollution risk to the environment or losses caused by pollution conditions (including asbestos) that may arise from the operations of the Contractor described in the Contractor's scope of services.**

Coverage pay for those sums the Contractor becomes legally obligated to pay as damages because of Bodily Injury, Property Damage or environmental Damage arising out of a pollution incident caused by the Contractor's work including Completed Operations. Coverage shall include emergency response expenses, pollution liability during transportation (if applicable) and at Non-Owned Waste Disposal Site (if applicable). The Minimum limits required are \$1,000,000 Per Occurrence/Loss and \$1,000,000 Policy Aggregate. If the coverage is written on a claims-made basis, the Contractor warrants that any retroactive date applicable to coverage under the policy precedes the effective date of this Contract; and that continuous coverage will be

maintained or an extended discovery period will be exercised for a period of three (3) years beginning from the time that work under this contract is completed. County shall be named as an additional insured for ongoing operations and completed operations.

vii. **Third Party Commercial Crime Insurance / Third Party Fidelity Bond**

**Delete Instruction: Crime / Third Party Fidelity covers the contractor and the contractor's employees when engaged in work for a client on behalf of the County. This coverage is for employee dishonesty, theft, embezzlement, forgery and alteration. Coverage is required when the contractor will be handling money or collecting fees on behalf of the County or when the contractor has access to client's personal property and/or documentation**

The Crime limit shall be \$1,000,000 Per Loss and include an endorsement for "Employee Theft of Client Property". In order to provide coverage to County during the course of this contract, Commercial Crime policies must be endorsed to cover Third Party Fidelity. Third party fidelity covers the vendor's employees when engaged in work for a client. In addition, the County will be listed as loss payee on the commercial crime coverage. This third-party coverage can also be provided by obtaining a third-party fidelity bond.

viii. **Privacy / Cyber Liability Insurance**

As a provider of a service which *may* require the knowledge and retention of personal identifiable information including but not limited to, names, dates of birth, social security numbers, usernames, and passwords, and/or HIPAA sensitive personal information of clients served, the following minimum insurance limits are required:

Contractors with 10 or fewer County clients:	\$50,000
Contractors with 11 – 15 County clients:	\$500,000
Contractors with more than 25 County clients:	\$1,000,000

**Delete Instruction: If the scope does not pertain to clients directly, contact Risk Management for appropriate language.**

ix. **Sexual Abuse and Molestation Coverage**

As a provider of a service which has contact with individuals that are part of a sensitive population and are in a position of trust the following minimum insurance limits are required:

Contractors with 5 or fewer County clients:	\$100,000
Contractors with 6-10 County clients:	\$250,000
Contractors with 11-15 County clients:	\$500,000
Contractors with 16 or more County clients:	\$1,000,000

If the number of clients increases during the contract period, the required coverage limit will increase to correspond accordingly.

**Delete Instruction: If the scope does not pertain to clients directly, contact Risk Management for appropriate language.**

**Delete Instruction: THE STATED INSURANCE LIMITS FOR ALL COVERAGES ARE MINIMUM AMOUNTS; DEPENDING ON THE CONTRACT, HIGHER LIMITS MAY BE REQUIRED OR ADVISABLE. CONTACT RISK MANAGEMENT IF YOU HAVE ANY QUESTIONS ABOUT MINIMUM LIMITS. DELETE THIS PARAGRAPH WHEN FINALIZING THE CONTRACT.**

[Signature Page to Follow]

IN WITNESS WHEREOF, the Parties have executed and entered into this Contract as of the latter day and year indicated below.

SIGNED for and on behalf of Boulder County	SIGNED for and on behalf of Contractor
Signature:	Signature:
Name:	Name:
Title:	Title:
Date:	Date:
↓↓ <i>For Board-signed documents only</i> ↓↓	
Attest:	<i>Initials</i>
Attestor Name:	
Attestor Title:	

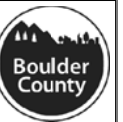

**Boulder County**  
 PUBLIC WORKS  
 BUILDINGS SERVICES  
 DIVISION  
 2525 13TH ST.  
 BOULDER, CO 80304  
 P.O. BOX 471 BOULDER, CO  
 80306  
 PHONE: 303.444.1859  
 sjacobs@bouldercounty.org

ELECTRICAL SCHEDULE										
KEY	QTY.	TYPE	DESCRIPTION	VOLT	AMP	WATT	LENGTH	MFR.	MODEL	REMARKS
E	2	LED	Interior light	120	x	x	x	x	x	x
F	1	LED	Exterior Porch light	120	x	x	x	x	x	x
G	2	x	Electric Heater	x	x	x	x	x	x	x
H	1	x	Hot Water Heater	240/208	x	x	x	x	x	x
J	2	x	H2O pump for vault	x	x	x	x	x	x	x

Vault Restroom General  
 Electrical Schedule  
 1/2" = 1'-0"

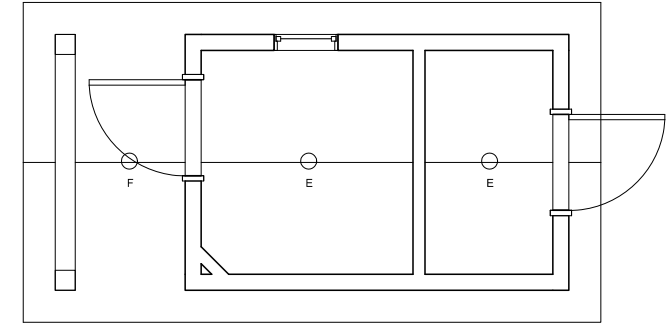

Vault Restroom Ceiling Plan  
 1/2" = 1'-0"

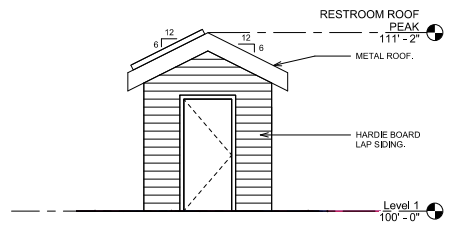

Vault Restroom East Elevation  
 1/4" = 1'-0"

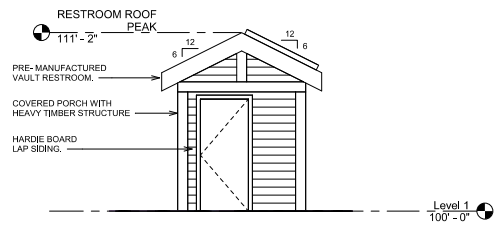

Vault Restroom West Elevation  
 1/4" = 1'-0"

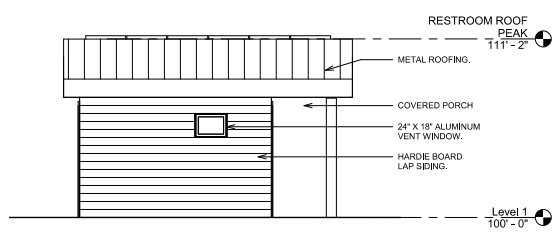

Vault Restroom North Elevation  
 1/4" = 1'-0"

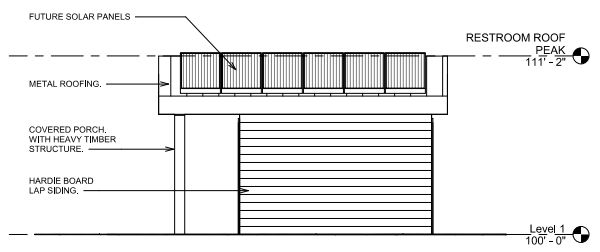

Vault Restroom South Elevation  
 1/4" = 1'-0"

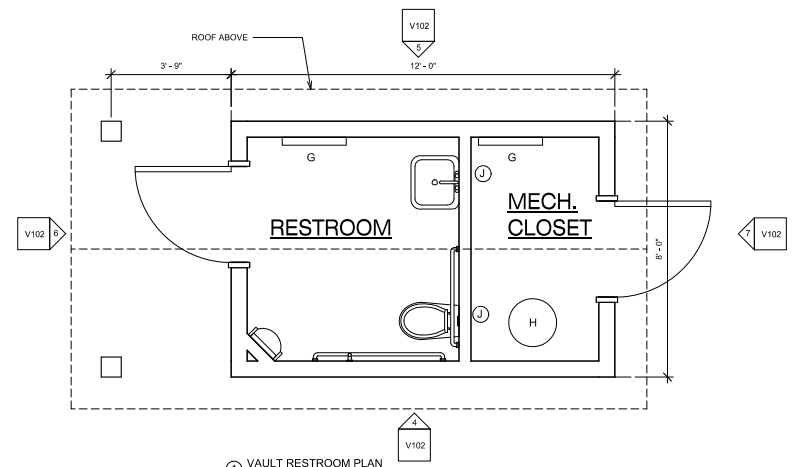

Vault Restroom Plan  
 1/2" = 1'-0"

**BOULDER COUNTY**  
 ALLENSPARK TRANSFER SITE EXPANSION  
 VAULT RESTROOM

**PROJECT**  
 ALLENSPARK TRANSFER  
 SITE EXPANSION  
**LOCATION**  
 14857 STATE  
 HIGHWAY 7  
 ALLENSPARK, CO  
 80510  
**SHEET**  
 VAULT RESTROOM PLANS  
 AND ELEVATIONS  
**FILE NAME**  
 014857 STATE HWY 7 - ALLENSPARK  
 TRANSFER SITE - VAULT RESTROOM  
**ACCT#** 101819  
**DATE** 02-14-22  
**DRAWN BY** SJA  
**CHECKED BY** JEB

**REVISIONS**

**SHEET**  
**V102**  
 OF 16