



Boulder County Purchasing
1325 Pearl Street
Boulder, CO 80302
purchasing@bouldercounty.org

INVITATION TO BID
COVER PAGE

BID Number: **7467-23**

BID Title: **Justice Center Lighting Control Upgrades**

BID Questions Due: May 5, 2023 – 2:00 p.m.

Submittal Due Date: May 16, 2023 – 2:00 p.m.

Email Address: purchasing@bouldercounty.org

Documents included in this package:

- Bid Instructions
- Terms and Conditions
- Specifications
- Insurance and W-9 Requirements
- Submittal Checklist
- Bid Tab Section
- Signature Page
- Sample Contract
- Specifications



Boulder County Purchasing
1325 Pearl Street
Boulder, CO 80302
purchasing@bouldercounty.org

INSTRUCTIONS

1. Purpose/Background

Boulder County is accepting bids for Watt Stopper lighting controls for the Boulder County Justice Center. We are seeking materials only. Installation and programming will be done by Boulder County's electrical contractor. No substitutes will be accepted. Please see the specifications at the end of this document. If you would like to see the floor plans for the Boulder County Justice Center, please fill out and return the non-disclosure agreement, attached separately, to purchasing@bouldercounty.org.

2. Written Inquiries

All inquiries regarding this BID will be submitted via email to the Boulder County Purchasing Office at purchasing@bouldercounty.org on or before 2:00 p.m. **May 5, 2023**. A response from the county to all inquiries will be posted and sent via email no later than **May 10, 2023**.

Do not contact any other county department or personnel with questions or for information regarding this solicitation.

3. Submittal Instructions

BIDs are due at the email box only, listed below, for time and date recording on or before **2:00 p.m. Mountain Time on May 16, 2023**. A bid opening will be conducted at 3:00 p.m. via Microsoft Teams. Please click on the link below or use the call-in number. A copy of the bid tab will also be sent to all who have submitted a Bid. **Vendors must answer whether line-item pricing information submitted with a bid is confidential or closely held.**

Microsoft Teams meeting

Join on your computer, mobile app or room device

[Click here to join the meeting](#)

Meeting ID: 284 687 063 200

Passcode: HenZrT

[Download Teams](#) | [Join on the web](#)

Or call in (audio only)

[+1 720-400-7859,403806787#](tel:+17204007859,403806787#) United States, Denver

Phone Conference ID: 403 806 787#

Please note that email responses to this solicitation are limited to a maximum of 50MB capacity.

NO ZIP FILES OR LINKS TO EXTERNAL SITES WILL BE ACCEPTED. THIS INCLUDES GOOGLE DOCS AND SIMILAR SITES. ALL SUBMITTALS MUST BE RECEIVED AS AN ATTACHMENT (E.G. PDF, WORD, EXCEL).

Electronic Submittals must be received in the email box listed below. Submittals sent to any other box will NOT be forwarded or accepted. This email box is only accessed on the due date of your questions or proposals. Please use the Delivery Receipt option to verify receipt of your email. It is the sole responsibility of the proposer to ensure their documents are received before the deadline specified above. Boulder County does not accept responsibility under any circumstance for delayed or failed email or mailed submittals.

Email purchasing@bouldercounty.org; identified as **BID # 7467-23** in the subject line.

All BIDs must be received and time and date recorded by authorized county staff by the above due date and time. Sole responsibility rests with the bidder to see that their BID response is received on time at the stated location(s). Any BIDs received after due date and time will be returned to the bidder.

The Board of County Commissioners reserves the right to reject any and all BIDs, to waive any informalities or irregularities therein, and to accept the proposal that, in the opinion of the Board, is in the best interest of the Board and of the County of Boulder, State of Colorado.

Contractors and their employees, subcontractors, and agents must comply with all federal, state, and local laws, regulations, ordinances, orders, and codes, as well as Boulder County policies, guidelines, and protocols.

Americans with Disabilities Act (ADA): Americans with Disabilities Act: If you need special services provided for under the Americans with Disabilities Act (ADA), please contact the Boulder County ADA Coordinator or Human Resources office at (303) 441-3525 as soon as possible to allow sufficient time for service delivery ahead of applicable due dates.



Boulder County Purchasing
1325 Pearl Street
Boulder, CO 80302
purchasing@bouldercounty.org

TERMS AND CONDITIONS

-
1. Bidders are expected to examine the drawing, specifications, schedule of delivery, and all instructions. Failure to do so will be at the bidder's risk.
 2. Each bidder will furnish the information required in the Invitation to Bid.
 3. The Contract/Purchase Order will be awarded to that responsible bidder whose submittal, conforming to the Invitation to Bid, will be most advantageous to the County of Boulder, based on best value not only price.
 4. The County of Boulder reserves the right to reject any or all bids and to waive informalities and minor irregularities in bids received, and to accept any portion of or all items proposed if deemed in the best interest of the County of Boulder to do so.
 5. No submittal will be withdrawn for a period of thirty (30) days subsequent to the opening of bids without the consent of the County Purchasing Agent or delegated representative.
 6. A signed purchase order or contract furnished to the successful bidder results in a binding contract without further action by either party.
 7. Late or unsigned bids will not be accepted or considered. It is the responsibility of bidders to ensure that the bid arrives at the Purchasing email address prior to the time indicated in the "Invitation to Bid."
 8. The proposed price will be exclusive of any Federal or State taxes from which the County of Boulder is exempt by law.
 9. Any interpretation, correction or change of the bid documents will be made by Addendum. Interpretations, corrections and changes of the bid documents made in any other manner will not be binding, and bidder will not rely upon such interpretations, corrections and changes. The County's Representative will not be responsible for oral clarification.
 10. Confidential/Proprietary Information: Bids submitted in response to this "Invitation to Bid" and any resulting contract are subject to the provisions of the Colorado Open Records Act, 24-72-201 et seq., C.R.S., as amended. Any restrictions on the use or inspection of material contained within the bid or resulting contract should be clearly stated in the bid and contract itself. Confidential/proprietary information should be readily identified, marked

and/or separated from the rest of the bid. Co-mingling of confidential/proprietary and other information is NOT acceptable. Vendors must answer whether line-item pricing information submitted with a bid is confidential or closely held. Bids that do not identify confidential/proprietary information may be released in their entirety. Pricing totals contained in a bid are not considered confidential.

The Boulder County Attorney's Office retains sole authority for determining whether the Colorado Open Records Act requires or permits Boulder County to disclose proposal or bid documents, or any information contained therein, pursuant to an open records request.

11. Boulder County promotes the purchase/leasing of energy efficient materials and products with low toxicity levels when availability, quality and budget constraints allow. Proposers are expected whenever possible to provide products that earn the ENERGY STAR and meet the ENERGY STAR specifications for energy efficiency with power management features enabled. Proposers are encouraged to offer products and equipment with post-consumer recycled-content materials. Products should be packaged and delivered with a minimum amount of recycled packaging that adequately protects the product but is not excessive.
12. Pursuant to Colorado law (House Bill 1292), in any bidding process for public works in which a bid is received from a non-resident bidder who is from a state that provides a percentage bidding preference, a comparable percentage disadvantage will be applied to the bid of that bidder. Bidders may obtain additional information from the Department of Personnel's website: <http://www.colorado.gov/dpa/>.



Boulder County Purchasing
1325 Pearl Street
Boulder, CO 80302
purchasing@bouldercounty.org

SPECIFICATIONS

Boulder County is accepting bids for Watt Stopper lighting controls for the Boulder County Justice Center. We are seeking materials only. Installation and programming will be done by Boulder County's electrical contractor. No substitutes will be accepted. Please see the specifications at the end of this document. If you would like to see the floor plans for the Boulder County Justice Center, please fill out and return the non-disclosure agreement, attached separately, to purchasing@bouldercounty.org.



Boulder County Purchasing
1325 Pearl Street
Boulder, CO 80302
purchasing@bouldercounty.org

W-9 REQUIREMENT

W-9 REQUIREMENT

Provide a copy of your business's W-9 with your proposal.



Boulder County Purchasing
1325 Pearl Street
Boulder, CO 80302
purchasing@bouldercounty.org

SUBMITTAL SECTION

The bidder's attention is especially called to the items listed below, which must be submitted in full as part of the BID. Failure to submit any of the documents listed below as a part of your BID, or failure to acknowledge any addendum in writing with your BID, or submitting a bid on any condition, limitation or provision not officially invited in this Invitation to Bid (BID) may be cause for rejection of the BID.

THIS CHECKLIST MUST BE SUBMITTED AS PART OF YOUR BID PACKAGE: Bidder will check each box indicating compliance:

INCLUDED	ITEM
	Name and Address of the Partners and Subcontractors if applicable
	A detailed project schedule with an all-inclusive total cost
	Information on the relevant experience of key personnel
	State your compliance with the Terms and Conditions in the Sample Contract contained in this BID. Specifically list any deviations and provide justification for each deviation.
	Submit three references for similar projects your company has completed within the last three years and contact information. Boulder County will review all contractor evaluation forms from previous County projects.
	Insurance Certificate
	W-9
	Signature Page
	Addendum Acknowledgement(s) (If Applicable)

THIS QUESTION MUST BE ANSWERED AS PART OF YOUR BID PACKAGE: Bidder will answer Yes or No indicating compliance:

YES OR NO	ITEM
	Do you customarily keep line-item pricing information, such as the information being submitted with this proposal, confidential or closely-held?



Boulder County Purchasing
1325 Pearl Street
Boulder, CO 80302
purchasing@bouldercounty.org

BID TAB

All materials described in the Drawings, Specifications and Addenda for this project:

_____dollars (\$_____)



Boulder County Purchasing
1325 Pearl Street
Boulder, CO 80302
purchasing@bouldercounty.org

SIGNATURE PAGE

Contact Information	Response
Company Name including DBA	
List Type of Organization (Corporation, Partnership, etc.)	
Name, Title, and Email Address of Person Authorized to Contract with Boulder County	
Company Address	
Company Phone Number	
Company Website	

By signing below I certify that:

I am authorized to bid on my company's behalf.

I am not currently an employee of Boulder County.

None of my employees or agents is currently an employee of Boulder County.

I am not related to any Boulder County employee or Elected Official.

(Sole Proprietorships Only) I am not a Public Employees' Retirement Association (PERA) retiree.

**Signature of Person Authorized to Bid on
 Company's Behalf**

Date

Note: If you cannot certify the above statements, please explain in a statement of explanation.

BOULDER COUNTY SAMPLE CONTRACT

THIS CONTRACT ("Contract") is entered into by and between the Board of County Commissioners on behalf of the County of Boulder, State of Colorado, a body corporate and politic, for the benefit of the [Department] ("County") and [Supplier] ("Contractor"). County and Contractor are each a "Party," and collectively the "Parties."

In consideration of the mutual covenants contained in this Contract, the receipt and sufficiency of which is hereby acknowledged, the Parties agree as follows:

1. Incorporation into Contract: The **Details Summary** is incorporated into this Contract. The **Contract Documents** are incorporated into this Contract by reference, except to the extent that the Proposal, if any is incorporated, contains any obligations placed upon County and not otherwise contained in this Contract.
2. Work to be Performed: Contractor will provide all labor and equipment and do all tasks necessary and incidental to performing the work as described in the **Details Summary** and **Contract Documents** (the "Work"). Contractor will perform the Work (a) in a good and workmanlike manner, (b) at its own cost and expense, (c) in accordance with recognized industry standards of care, skill and diligence for the type of work being performed, and (d) in strict accordance with the Contract.
3. Term of Contract: The **Contract Term** begins on the **Start Date** and expires on the **Expiration Date**, unless terminated sooner. All the Work must be performed during the **Contract Term**.
4. Payment for Work Performed: In consideration of the Work performed by Contractor, and subject to conditions contained in this Contract, County will pay an amount not to exceed the **Contract Amount** to Contractor in accordance with the **Contract Documents**.
5. Invoicing: Contractor will promptly provide a copy of its Form W-9 and invoice template to County upon request. Contractor must submit an invoice to the County by the fifteenth (15th) day of the month for completion of any Work performed in the prior calendar month. All invoices submitted require the following components: Contractor's name and address (submitted W-9 address must match remit address), detailed description of services, dates of services, itemization of labor and materials costs, "Bill to: Boulder County" language, payment remittance address, payer, name and address, date of invoice, unique invoice number, and total amount due. Contractor must send all completed invoices to the **Invoice Contact** in the **Details Summary**. County may require delivery of invoices by email. Failure to submit invoices in a timely manner and in accordance with the terms of this Contract may cause a delay in payment. County may recoup any damages incurred because of Contractor's failure to submit invoices pursuant to the terms of this paragraph. County's acceptance or payment of an invoice will not constitute acceptance of any Work performed under this Contract.
6. Extra Time to Complete the Work (Additional Time only): If Contractor cannot complete the Work by the **Expiration Date**, Contractor may request extra time to complete the Work. County, in its sole discretion, may grant Contractor additional time to complete the Work by sending a written notice of extension to Contractor. An extension of time to complete the Work does not entitle Contractor to additional compensation from County.
7. Extension of Contract Term (Additional Time and Work): Upon mutual agreement of the Parties, this Contract may be extended until the **Final End Date**. During any extended **Contract Term**, the terms of this Contract will remain in full force and effect, unless otherwise amended in writing by the Parties. Where the Contractor will provide additional services for additional compensation beyond the initial **Contract Amount**, the Parties must execute a written amendment before the then-current **Expiration Date**. If necessary, the written amendment will incorporate an updated Scope of Work and updated Fee Schedule as exhibits. Contractor must provide a current Certificate of Insurance to the County that complies with the **Insurance Requirements** of this Contract, if any, prior to any extended **Contract Term**.

8. Schedule of Work: County may designate the hours (on a daily or weekly basis) during which Contractor may perform the Work, strictly for the purposes of minimizing inconvenience to the County and interference with County operations. Contractor will otherwise set its own work schedule.

9. Indemnity: Contractor will be liable for any damages to persons or property caused by or arising out of the actions, obligations, or omissions of Contractor, its employees, agents, representatives or other persons acting under Contractor's direction or control in performing or failing to perform the Work under this Contract. Contractor will indemnify and hold harmless County, its elected officials and appointed department heads, and its employees, agents and representatives (the "indemnified parties"), from any and all liability, claims, demands, actions, damages, losses, judgments, costs or expenses, including attorneys' fees, which may be made or brought or which may result against any of the indemnified parties as a result or on account of the actions or omissions of Contractor, its employees, agents or representatives, or other persons acting under Contractor's direction or control. This indemnification obligation will extend to claims based on Contractor's unauthorized use or disclosure of confidential information and intellectual property infringement. County will not be obligated to indemnify or defend Contractor under any circumstances. Contractor's obligations under this provision shall survive expiration or termination of this Contract. Nothing contained in this Contract or the **Contract Documents** is intended to limit or restrict the indemnification rights or obligations of any Party under this provision, or damages available for breaches of the obligations herein.

10. Nondiscrimination: Contractor will comply with the Colorado Anti-Discrimination Act, C.R.S. § 24-34-401, et seq., as amended, and all applicable local, State and Federal laws concerning discrimination and unfair employment practices. County prohibits unlawful discrimination on the basis of race, color, religion, gender, gender identity, national origin, age 40 and over, disability, socio-economic status, sexual orientation, genetic information, or any other status protected by applicable Federal, State or local law. Contractor must require that its subcontractors, if any, similarly comply with all applicable laws concerning discrimination and unfair employment practices.

11. Information and Reports: Contractor will provide to authorized County, State, and Federal government representatives all information and reports that may be required for any purpose authorized by law. Contractor will permit access to such representatives to Contractor's facilities, books, records, accounts, and any other relevant sources of information. Where information required by a representative is in the exclusive possession of a person or entity other than Contractor, Contractor must so certify to the County and explain what efforts it has made to obtain the information.

12. Independent Contractor: **Contractor is an independent contractor for all purposes in performing the Work. None of Contractor, its agents, personnel or subcontractors are employees of the County for any purpose, including the Federal Insurance Contribution Act, the Social Security Act, the Federal Unemployment Tax Act, the provisions of the Internal Revenue Code, the Colorado Workers' Compensation Act, the Colorado Unemployment Insurance Act, and the Public Employees Retirement Association. Accordingly, County will not withhold or pay any income tax, payroll tax, or retirement contribution of any kind on behalf of Contractor or Contractor's employees. As an independent contractor, Contractor is responsible for employing and directing such personnel and agents as it requires to perform the Work. Contractor will exercise complete authority over its personnel and agents and will be fully responsible for their actions.**

13. Termination

a. Breach: Either Party's failure to perform any of its material obligations under this Contract, in whole or in part or in a timely or satisfactory manner, will be a breach. The institution of proceedings under any bankruptcy, insolvency, reorganization or similar law, by or against Contractor, or the appointment of a receiver or similar officer for Contractor or any of its property, which is not vacated or fully stayed within thirty (30) days after the institution of such proceeding, will also constitute a breach. In the event of a breach, the non-breaching Party may provide written notice of the breach to the other Party. If the breaching Party does not cure the breach, at its sole expense, as reasonably determined by the non-breaching Party in its sole discretion, within thirty (30) days after delivery of notice, the non-breaching Party may exercise any of its remedies provided under this Contract or at law, including immediate termination of this Contract.

b. Non-Appropriation: The other provisions of this Contract notwithstanding, County is prohibited by law from making commitments beyond the current fiscal year. Payment to Contractor beyond the current fiscal year is contingent on the appropriation and continuing availability of funding in any subsequent year. County has reason

to believe that sufficient funds will be available for the full **Contract Term**. Where, however, funds are not allocated for any fiscal period beyond the current fiscal year, County may terminate this Contract without penalty by providing seven (7) days' written notice to Contractor.

c. Convenience: In addition to any other right to terminate under this Section 13, County may terminate this Contract, in whole or in part, for any or no reason, upon seven (7) days' advance written notice to Contractor.

14. Contractor Obligations upon Termination or Expiration: By the **Expiration Date** or effective date of termination, if earlier, Contractor must (1) remove from County property all of its personnel, equipment, supplies, trash and any hazards created by Contractor, (2) protect any serviceable materials belonging to the County, and (3) take any other action necessary to leave a safe and healthful worksite. Any items remaining on County property after the Expiration Date or the effective date of termination, if earlier, will be deemed abandoned by Contractor.

15. Payable Costs in Event of Early Termination: If County terminates this Contract before the **Expiration Date**, Contractor's payments (and any damages associated with any lawsuit brought by Contractor) are limited to only (1) payment for Work satisfactorily executed and fully and finally completed, as determined by County in its sole discretion, prior to delivery of the notice to terminate, and (2) the reasonable and actual costs Contractor incurred in connection with performing the Work prior to delivery of the notice to terminate. Contractor explicitly waives all claims it may have against the County for any other compensation, such as anticipatory profits or any other consequential, special, incidental, punitive or indirect damages.

16. Remedies for Non-Performance: If Contractor fails to perform any of its obligations under this Contract, County may, at its sole discretion, exercise one or more of the following remedies (in addition to any other remedies provided by law or in this Contract), which shall survive expiration or termination of this Contract:

a. Suspend Performance: County may require that Contractor suspend performance of all or any portion of the Work pending necessary corrective action specified by the County and without entitling Contractor to an increase in compensation or extension of the performance schedule. Contractor must promptly stop performance and incurring costs upon delivery of a notice of suspension by the County.

b. Withhold Payment Pending Corrections: County may permit Contractor to correct any rejected Work at the County's discretion. Upon County's request, Contractor must correct rejected work at Contractor's sole expense within the time frame established by the County. Upon full and final completion of the corrections satisfactory to the County, County will remit payment to Contractor.

c. Deny Payment: County may deny payment for any Work that does not comply with the requirements of the Contract or that Contractor otherwise fails to provide or fully and finally complete, as determined by the County in its sole discretion. Upon County request, Contractor will promptly refund any amounts prepaid by the County with respect to such non-compliant Work.

d. Removal: Upon County's request, Contractor will remove any of its employees or agents from performance of the Work, if County, in its sole discretion, deems any such person to be incompetent, careless, unsuitable, or otherwise unacceptable.

17. Binding Arbitration Prohibited: County does not agree to binding arbitration by any extra-judicial body or person.

18. Conflicts of Interest: Contractor may not engage in any business or personal activities or practices or maintain any relationships that conflict in any way with the full performance of Contractor's obligations.

19. Notices: All notices provided under this Contract must be in writing and sent by Certified U.S. Mail (Return Receipt Requested), electronic mail, or hand-delivery to the other Party's **Contact** at the address specified in the **Details Summary**. For certified mailings, notice periods will begin to run on the day after the postmarked date of mailing. For electronic mail or hand-delivery, notice periods will begin to run on the date of delivery.

20. Statutory Requirements: This Contract is subject to all statutory requirements that are or may become applicable to counties or political subdivisions of the State of Colorado generally, including but not limited to: C.R.S. § 38-26-107, which requires withholding funds where the County receives a claim for payment from a supplier or subcontractor of Contractor upon notice of final settlement (required for public works contracts that exceed \$150,000); C.R.S. § 8-17-101 et seq.; C.R.S. § 18-8-301, et seq.; and C.R.S. § 18-8-401, et seq.
21. No Suspension or Debarment: Contractor certifies, and warrants for the Contract Term, that neither it nor its principals nor any of its subcontractors are debarred, suspended, proposed for debarment, declared ineligible, or voluntarily excluded from participation in this Contract by any Federal or State department or agency. Contractor shall comply, and shall require its subcontractors to comply, with subpart C of 2 C.F.R. § 180.
22. Entire Agreement/Binding Effect/Amendments: This Contract represents the complete agreement between the Parties and is fully binding upon them and their successors, heirs, and assigns, if any. This Contract terminates any prior agreements, whether written or oral in whole or in part, between the Parties relating to the Work. This Contract may be amended only by a written agreement signed by both Parties.
23. Assignment/Subcontractors: This Contract may not be assigned or subcontracted by Contractor without the prior written consent of the County. If Contractor subcontracts any of its obligations under this Contract, Contractor will remain liable to the County for those obligations and will also be responsible for subcontractor's performance under, and compliance with, this Contract.
24. Governing Law/Venue: The laws of the State of Colorado govern the construction, interpretation, performance, and enforcement of this Contract. Any claim relating to this Contract or breach thereof may only be brought exclusively in the Courts of the 20th Judicial District of the State of Colorado and the applicable Colorado Appellate Courts.
25. Breach: The failure of either Party to exercise any of its rights under this Contract will not be deemed to be a waiver of such rights or a waiver of any breach of the Contract. All remedies available to a Party in this Contract are cumulative and in addition to every other remedy provided by law.
26. Severability: If any provision of this Contract becomes inoperable for any reason but the fundamental terms and conditions continue to be legal and enforceable, then the remainder of the Contract will continue to be operative and binding on the Parties.
27. Third-Party Beneficiary: Enforcement of the terms and conditions and all rights and obligations of this Contract are reserved to the Parties. Any other person receiving services or benefits under this Contract is an incidental beneficiary only and has no rights under this Contract. Notwithstanding, where the beneficiary **Department** is led by an Elected Official, such Elected Official shall be considered a third-party beneficiary.
28. Colorado Open Records Act: County may disclose any records that are subject to public release under the Colorado Open Records Act, C.R.S. § 24-72-200.1, et seq.
29. Conflict of Provisions: If there is any conflict between the terms of the main body of this Contract and the terms of any of the **Contract Documents**, the terms of the main body of the Contract will control.
30. Governmental Immunity: Nothing in this Contract shall be construed in any way to be a waiver of the County's immunity protection under the Colorado Governmental Immunity Act, C.R.S. § 24-10-101, et seq., as amended.
31. Representations and Warranties: Contractor represents and warrants the following:
- a. Execution of this Contract and performance thereof is within Contractor's duly authorized powers;
 - b. The individual executing this Contract is authorized to do so by Contractor;
 - c. Contractor is authorized to do business in the State of Colorado and is properly licensed by all necessary governmental and public and quasi-public authorities having jurisdiction over the Work and the Contractor; and
 - d. Contractor and its subcontractors, if any, are financially solvent, able to pay all debts as they mature, and have sufficient working capital to complete the Work and perform all obligations under the Contract.

32. Legal Compliance: Contractor assumes full responsibility for obtaining and maintaining any permits and licenses required to perform the Work. Contractor is solely responsible for ensuring that its performance under this Contract and the Work itself will comply with all Federal, State, and local laws, regulations, ordinances and codes. County approval of the Work or any aspect of Contractor's performance, such as plans, designs, or other Contractor-drafted documents, shall not be interpreted to mean that Contractor has satisfied its obligations under this Section.
33. Litigation Reporting: Contractor is not currently involved in any action before a court or other administrative decision-making body that could affect Contractor's ability to perform the Work. Contractor will promptly notify the County if Contractor is served with a pleading or other document in connection with any such action.
34. Tax Exemption: County is exempt from payment of Federal, State, and local government taxes. Contractor shall collect no tax from the County, and the County shall not be liable to pay any taxes imposed on Contractor. County shall provide its tax exemption status information to Contractor upon request.
35. Delegation of Authority: The Parties acknowledge that the Board of County Commissioners has delegated authority to the Department Head or Elected Official that leads the beneficiary **Department** and their designees to act on behalf of the County under the terms of this Contract, including but not limited to the authority to terminate this Contract.
36. Ownership of Work Product: All work product, property, data, documentation, information or materials conceived, discovered, developed or created by Contractor pursuant to this Contract ("Work Product") will be owned exclusively by the County. To the extent possible, any Work Product will be deemed to be a work made for hire. Contractor unconditionally and irrevocably transfers and assigns to the County all right, title and interest in and to any Work Product.
37. Publicity Releases: Contractor will not refer to this Contract or the County in commercial advertising without prior written consent of the County. This provision shall survive expiration or termination of this Contract.
38. Execution by Counterparts; Electronic Signatures: This Contract may be executed in multiple counterparts, each of which will be deemed an original, but all of which will constitute one agreement. The Parties approve the use of electronic signatures, governed by the Uniform Electronic Transactions Act, C.R.S. §§ 24 71.3 101 to 121. The Parties will not deny the legal effect or enforceability of this Contract solely because it is in electronic form or because an electronic record was used in its creation. The Parties will not object to the admissibility of this Contract in the form of electronic record, or paper copy of an electronic document, or paper copy of a document bearing an electronic signature, because it is not in its original form or is not an original.
39. Limitation on Public Statements and Lobbying Activity. During the term of this Contract, Contractor may receive from the County its confidential data, work product, or other privileged or confidential information that is protected by law. To maintain the fact and appearance of absolute objectivity, Contractor shall not, without the prior written consent of the County, which shall not be unreasonably withheld, do any of the following: (a) disclose information obtained because of this contractual relationship to any third party; (b) lobby any State or Federal agency on any pending matter while this Contract is effective; or (c) make any public statements or appear at any time to give testimony at any public meeting on the subject matters regarding which Contractor is or was retained by the County. County may set reasonable conditions on any disclosure authorized by the County under this provision. Notwithstanding, Contractor may make disclosures as required by law, and to law enforcement officials in connection with any criminal justice investigation.
40. Sustainability: County encourages Contractor to consider the procurement and use of environmentally preferable products and services while performing services under this Contract. "Environmentally preferable purchasing" means making purchasing choices for products and services that have a lesser or reduced adverse effect on human health and the environment when compared with competing products and services that serve the same purpose. Environmentally preferable purchasing is consistent with the County's commitment to protecting our air, water, soil, and climate for current and future generations. County encourages Contractor to incorporate the following actions into Contractor's performance of the Work: environmentally preferable supplies and services; conservation of water; efficient energy use; waste prevention; reuse and recycle construction and de-construction materials in a manner that maximizes reuse of materials; sustainable transportation choices, including consideration

to business communication software such as Skype alternative to air travel and public transit or carpooling for in-person meetings; pollution prevention; low toxicity for public health & safety; and reduced emissions to address climate change.

41. Limitation of Liability: COUNTY SHALL NOT BE LIABLE TO CONTRACTOR FOR ANY SPECIAL, CONSEQUENTIAL, INCIDENTAL, PUNITIVE, OR INDIRECT DAMAGES ARISING FROM OR RELATING TO THIS CONTRACT, REGARDLESS OF ANY NOTICE OF THE POSSIBILITY OF SUCH DAMAGES. COUNTY'S AGGREGATE LIABILITY, IF ANY, ARISING FROM OR RELATED TO THIS CONTRACT, WHETHER IN CONTRACT, OR IN TORT, OR OTHERWISE, IS LIMITED TO, AND SHALL NOT EXCEED, THE AMOUNTS PAID OR PAYABLE HEREUNDER BY COUNTY TO CONTRACTOR. ANY CONTRACTUAL LANGUAGE LIMITING CONTRACTOR'S LIABILITY SHALL BE VOID.

42. Legal Interpretation. Each Party recognizes that this Contract is legally binding and acknowledges that it has had the opportunity to consult with legal counsel of its choice about this Contract. The rule of construction providing that any ambiguities are resolved against the drafting Party will not apply in interpreting the terms of this Contract.

43. Insurance: Prior to commencing the Work, Contractor will provide a Certificate of Insurance to the County demonstrating adequate insurance coverage as required by this Section. All policies evidencing coverage required by the Contract will be issued by insurance companies satisfactory to the County. Contractor will forward Certificates of Insurance directly to the **County Department** and **Contact** listed in the **Details Summary**.

a. Boulder County as Additional Insured: Boulder County shall be named as an additional insured for General Liability, Umbrella/Excess Liability, and Pollution Liability, as designated in this Contract. Additional insured shall be endorsed to the policy.

THE ADDITIONAL INSURED WORDING SHOULD BE AS FOLLOWS: *County of Boulder, State of Colorado, a body corporate and politic, is named as Additional Insured.*

b. Notice of Cancellation: Each insurance policy required by this Contract shall provide the required coverage and shall not be suspended, voided or canceled except after thirty (30) days' prior written notice has been given to the County except when cancellation is for non-payment of premium, then ten (10) days' prior notice may be given. If any insurance company refuses to provide the required notice, Contractor or its insurance broker shall notify the County any cancellation, suspension, or nonrenewal of any insurance policy within seven (7) days of receipt of insurers' notification to that effect.

c. Insurance Obligations of County: County is not required to maintain or procure any insurance coverage beyond the coverage maintained by the County in its standard course of business. Any insurance obligations placed on the County in any of the **Contract Documents** shall be null and void.

d. Deductible: Any and all deductibles contained in any insurance policy shall be assumed by and at the sole risk of Contractor.

e. Primacy of Coverage: Coverage required of Contractor and its subcontractors, if any, shall be primary over any insurance or self-insurance program carried by the County.

f. Subrogation Waiver: All insurance policies in any way related to this Contract secured or maintained by Contractor as required herein shall include clauses stating that each carrier shall waive all rights of recovery, under subrogation or otherwise, against County, its organizations, officers, agents, employees, and volunteers.

g. Requirements: For the entire duration of this Contract including any extended or renewed terms, and longer as may be required by this Contract, Contractor shall procure and maintain at its own expense, and without cost to the County, the following kinds and minimum amounts of insurance to insure the liability risks that Contractor has assumed under this Contract:

i. **Commercial General Liability**

Delete Instruction: Non-Construction contracts use the following language:

This coverage should be provided on an Occurrence Form, ISO CG001 or equivalent, with Minimum limits of \$1,000,000 Each Occurrence, \$2,000,000 General Aggregate and \$2,000,000 Products Completed Operations Aggregate.

Delete Instruction: Construction Contracts only – include the following paragraph:

Coverage should be provided on an Occurrence form, ISO CG0001 or equivalent. The policy shall be endorsed to include Additional Insured Owners, Lessees or Contractors endorsements CG 2038 (or equivalent), Designated Construction Project(s) General Aggregate Endorsement CG2503 (or equivalent) and Additional Insured Completed Operations for Owners, Lessees or Contractors CG 2037 (or equivalent). Minimum limits required of \$1,000,000 Each Occurrence, \$2,000,000 General Aggregate and \$2,000,000 Products/Completed Operations Aggregate. The County requires the Products/Completed Operations coverage to be provided 3 years after completion of construction. An endorsement must be included with the certificate.

ii. **Automobile Liability**

Bodily Injury and Property Damage for any owned, hired, and non-owned vehicles used in the performance of the Contract. Minimum limits \$1,000,000 Each Accident.

Delete Instruction: This coverage may not be required if Contractor is not using a vehicle as part of its performance under the contract. Contact Risk Management with any questions.

iii. **Workers' Compensation and Employer's Liability**

Workers' Compensation must be maintained with the statutory limits. Employer's Liability is required for minimum limits of \$100,000 Each Accident/\$500,000 Disease-Policy Limit/\$100,000 Disease-Each Employee.

Delete Instruction: This coverage may not be required if contractor is not mandated under State law to maintain this coverage. A waiver is available on the contracts routing website.

iv. **Umbrella / Excess Insurance**

Umbrella/Excess Liability insurance in the amount \$[X],000,000.00, following form.

Delete Instruction: This insurance is a broad, high-limit policy, which acts more than the underlying primary insurance policy. This coverage is designed to provide additional liability limits beyond the primary insurance limits and is triggered upon the underlying limits becoming exhausted. Umbrella / Excess insurance is most commonly required when an exposure to the County could potentially create liabilities in excess of the basic insurance limits. The most common limits for these policies range from \$2,000,000 to \$5,000,000.

Delete Instruction: Please consult with Risk Management if you feel this coverage should be required.

Delete Instruction: IN ADDITION TO THE ABOVE, ONE OR MORE OF THE FOLLOWING FOUR (4) INSURANCE COVERAGES MAY BE REQUIRED. CONTACT RISK MANAGEMENT IF YOU HAVE QUESTIONS ABOUT WHICH INSURANCE COVERAGE TO INCLUDE. DELETE THIS INSTRUCTION (AND ANY INAPPLICABLE INSURANCE PARAGRAPHS) WHEN FINALIZING THE CONTRACT:

v. **Professional Liability (Errors and Omissions)**

Delete Instruction: All contractors required to be professionally certified by the State of Colorado (i.e., architects, engineers, doctors, nurses, etc.) and/or any consultants whose errors in judgment, planning,

design, etc. could result in economic loss to the County must provide proof of professional liability coverage. This also applies to anyone managing or overseeing construction.

Professional liability coverage with minimum limits of \$1,000,000 Per Loss and \$1,000,000 Aggregate. Professional Liability provisions indemnifying for loss and expense resulting from errors, omission, mistakes or malpractice is acceptable and may be written on a claims-made basis. The contractor warrants that any retroactive date under the policy shall precede the effective date of this Contract; and that either continuous coverage will be maintained or an extended discovery period will be exercised for a period of two (2) years beginning at the time work under this Contract is completed.

vi. **Pollution Liability**

Delete Instruction: This coverage is required whenever work under the contract involves pollution risk to the environment or losses caused by pollution conditions (including asbestos) that may arise from the operations of the Contractor described in the Contractor's scope of services.

Coverage pay for those sums the Contractor becomes legally obligated to pay as damages because of Bodily Injury, Property Damage or environmental Damage arising out of a pollution incident caused by the Contractor's work including Completed Operations. Coverage shall include emergency response expenses, pollution liability during transportation (if applicable) and at Non-Owned Waste Disposal Site (if applicable). The Minimum limits required are \$1,000,000 Per Occurrence/Loss and \$1,000,000 Policy Aggregate. If the coverage is written on a claims-made basis, the Contractor warrants that any retroactive date applicable to coverage under the policy precedes the effective date of this Contract; and that continuous coverage will be maintained or an extended discovery period will be exercised for a period of three (3) years beginning from the time that work under this contract is completed. County shall be named as an additional insured for ongoing operations and completed operations.

vii. **Third Party Commercial Crime Insurance / Third Party Fidelity Bond**

Delete Instruction: Crime / Third Party Fidelity covers the contractor and the contractor's employees when engaged in work for a client on behalf of the County. This coverage is for employee dishonesty, theft, embezzlement, forgery and alteration. Coverage is required when the contractor will be handling money or collecting fees on behalf of the County or when the contractor has access to client's personal property and/or documentation

The Crime limit shall be \$1,000,000 Per Loss and include an endorsement for "Employee Theft of Client Property". In order to provide coverage to County during the course of this contract, Commercial Crime policies must be endorsed to cover Third Party Fidelity. Third party fidelity covers the vendor's employees when engaged in work for a client. In addition, the County will be listed as loss payee on the commercial crime coverage. This third-party coverage can also be provided by obtaining a third-party fidelity bond.

viii. **Privacy / Cyber Liability Insurance**

As a provider of a service which may require the knowledge and retention of personal identifiable information including but not limited to, names, dates of birth, social security numbers, usernames, and passwords, and/or HIPAA sensitive personal information of clients served, the following minimum insurance limits are required:

Contractors with 10 or fewer County clients:	\$50,000
Contractors with 11 – 15 County clients:	\$500,000
Contractors with more than 25 County clients:	\$1,000,000

Delete Instruction: If the scope does not pertain to clients directly, contact Risk Management for appropriate language.

ix. **Sexual Abuse and Molestation Coverage**

As a provider of a service which has contact with individuals that are part of a sensitive population and are in a position of trust the following minimum insurance limits are required:

Contractors with 5 or fewer County clients:	\$100,000
Contractors with 6-10 County clients:	\$250,000
Contractors with 11-15 County clients:	\$500,000
Contractors with 16 or more County clients:	\$1,000,000

If the number of clients increases during the contract period, the required coverage limit will increase to correspond accordingly.

Delete Instruction: If the scope does not pertain to clients directly, contact Risk Management for appropriate language.

Delete Instruction: THE STATED INSURANCE LIMITS FOR ALL COVERAGES ARE MINIMUM AMOUNTS; DEPENDING ON THE CONTRACT, HIGHER LIMITS MAY BE REQUIRED OR ADVISABLE. CONTACT RISK MANAGEMENT IF YOU HAVE ANY QUESTIONS ABOUT MINIMUM LIMITS. DELETE THIS PARAGRAPH WHEN FINALIZING THE CONTRACT.

[Signature Page to Follow]

IN WITNESS WHEREOF, the Parties have executed and entered into this Contract as of the latter day and year indicated below.

SIGNED for and on behalf of Boulder County		SIGNED for and on behalf of Contractor	
Signature:		Signature:	
Name:		Name:	
Title:		Title:	
Date:		Date:	
↓↓ <i>For Board-signed documents only</i> ↓↓			
Attest:		<i>Initials</i>	
Attestor Name:			
Attestor Title:			

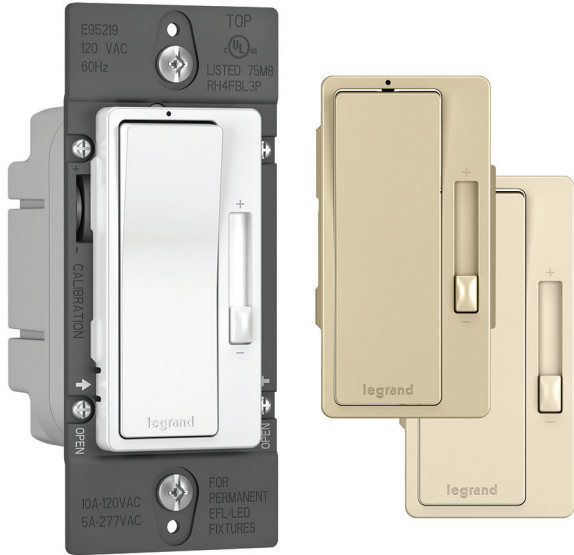

RH4FBL3PTC

A simple solution for 0-10V dimming.

RH4FBL3PTC/RH4FBL3PW

Legrand Dimmers have always been known for style. But now, thanks to customer input, they're known for added simplicity as well. The new radiant 0-10V dimmer controls all the latest LED and fluorescent fixtures in one wall box control (0-10V style fixtures). That means no requirement for a separate power pack.

Interchangeable face covers are available for the dimmers in a variety of popular colors. Each dimmer also has a white LED that glows when the light is turned OFF, making it easier to find in the dark.

Ideal for use in residential and commercial applications, the radiant 0-10V LED and fluorescent dimmer is the simple solution for all your 0-10V control needs, and, as part of the radiant collection, now offers a better fit, form and finish.

Features & Benefits

Trim adjustment allows users to fine tune the dimmer performance to the fixture.

Convenient operation combines ON/OFF paddle switch with separate slider for dimming control.

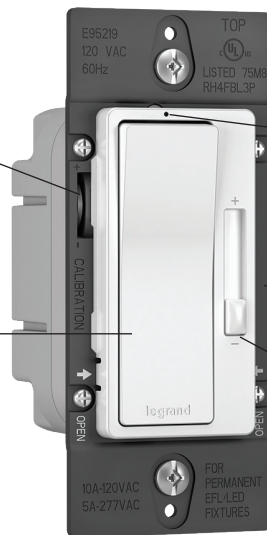

White LED glows when OFF to make dimmer easy to find in the dark.

Sleek, ergonomic design that matches today's styles.

Wider slide controller for easier dimming operation.

RH4FBL3PW

- **Preset, Single Pole and 3-Way operation:** Support for both 120VAC and 277VAC applications.

- **Interchangeable face plates** available in eight colors (RHKIT*; sold separately).

3rd Party Compliance

-  cULus Listed, UL1472, CSA-C22.2 No. 184.1-95. Conforms to NEMA WD-1 and WD-6, California Title 24 Compliant.

Technical Information

Performance

Electrical	
Supply Voltage	120 VAC / 277VAC
Ratings	120V 10A / 277V 5A
Frequency	60 Hz
Control	0-10VDC 30mA
Installation	Single Pole or 3-Way
Environmental	
Application	Indoor Use Only
Mechanical	
Enclosure Material	Polycarbonate

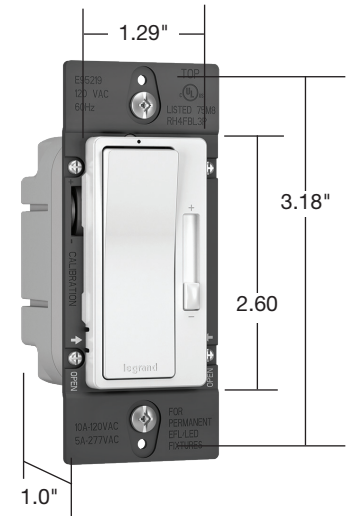

RH4FBL3PW

Warranty

Lifetime

Ordering Information

radiant® 0-10V Fluorescent Dimmers

Catalog Number	Description	Color	Voltage	Rating
RH4FBL3PTC	Preset, Single Pole and 3-Way	Three interchangeable Face Colors: Ivory, White, Light Almond	120 VAC, 60Hz 277 VAC, 60Hz	120VAC 10A 277VAC 5A 0-10V DC 30mA Sink
RH4FBL3PW	Preset, Single Pole and 3-Way	Face Color: White	120 VAC, 60Hz 277 VAC, 60Hz	120VAC 10A 277VAC 5A 0-10V DC 30mA Sink
RHKIT	Interchangeable Faces	Brown		
RHKITBK		Black		
RHKITGRY		Gray		
RHKITI		Ivory		
RHKITLA		Light Almond		
RHKITNI		Nickel		
RHKITW		White		
RHKITDB		Dark Bronze		

All devices are cULus Listed.

Vertical Markets

- Residential
- Light Commercial
- Health Care
- Retail/Office
- Education
- Hospitality/Lodging

Also available in the radiant® collection

- GFCI Receptacles
- Tamper-Resistant and Standard Duplex Receptacles
- Paddle Switches
- Fan Controls
- Sensors
- Timers
- Home Automation Controls
- USB Charging Devices
- Night Lights
- Screwless Wall Plates

 The paper used to print this document is an environmentally responsible paper with 10% post consumer waste, with FSC and SFI Chain of Custody certifications, Lacey Act compliant. 100% of the electricity used to manufacture Flo sheets is generated with Green-e certified renewable energy.

All brand and product names referenced in this document are registered trademarks or trademarks of their respective holders.



Legrand, North America
60 Woodlawn Street
West Hartford, CT 06110
1.877.BY.LEGRAND (295.3472)
www.legrand.us

570 Applewood Crescent
Vaughan, Ontario L4K 4B4
905.738.9195
www.legrand.ca

FOLLOW US

