



Boulder County Purchasing
1325 Pearl Street
Boulder, CO 80302
purchasing@bouldercounty.org

INVITATION TO BID
COVER PAGE

BID Number: 7476-23

BID Title: St Vrain Forestry Yard Gate Installation

BID Questions Due: June 20, 2023 – 2:00 p.m.

Submittal Due Date: **JUNE 28, 2023 – 2:00 p.m.**

Email Address: purchasing@bouldercounty.org

Documents included in this package:

- BID Instructions
- Bond Requirements
- Terms and Conditions
- Specifications
- Insurance and W-9 Requirements
- Bid Tab Section
- Submittal Checklist
- Signature Page
- Attachment A: Gate Design and Specifications
- Attachment B: Site Plan
- Attachment C: Purchase Order Terms
- Attachment D: Sample Contract



Boulder County Purchasing
1325 Pearl Street
Boulder, CO 80302
purchasing@bouldercounty.org

BID INSTRUCTIONS

BACKGROUND:

The Boulder County Parks and Open Space Department (BCPOS) is soliciting bids from qualified and experienced firms to construct and install a galvanized metal gate for the BCPOS Forestry Storage Yard at the Ramey (Shadi) Property. The property is located at 7698 St Vrain Rd Longmont, CO 80503. The gate is part of a sound mitigation system that will reduce the amount noise to neighboring properties from activities at the yard.

The selected Contractor will provide all deliverables for the project within thirty (30) calendar days from the date of the Notice to Proceed.

CONTRACT LANGUAGE:

The successful bidder will be required to enter into a Contract for Services and meet all insurance requirements as required prior to any work beginning.

All bidders are instructed to thoroughly review all the stated insurance requirements for this Project, the insurance requirements stated are the minimum and standard for Boulder County Government, for this Project. All hired contractors are required to meet the insurance requirements, as stated, for contracted services as part of the Boulder County contracting process. Owner/Sole Proprietors/Officer are not Exempt from the county's insurance requirements and coverage limits. Please refer to the Insurance Requirements in this BID.

In the event the selected contractor is unable to commence work as agreed to, the Boulder County Commissioners may rescind the bid award and proceed to award the contract to another bidder based on this BID, re-bid the work, or proceed in any lawful manner the County deems necessary.

PAYMENT & PERFORMANCE BONDS:

Payment and Performance Bond requirements are addressed in the attached Sample Contract. Payment and Performance bonds will be required for bids over \$50,000.00. Bonds must be received and approved, by the County, prior to work commencing. If applicable, Retainage and a Notice of Final Settlement posting will be required.

PAYMENT FOR SERVICES:

Upon completion of the project the Design Engineer and the BCPOS Project Manager will inspect the work. Upon approval of work the selected Contractor may submit their invoice and will be paid in one lump sum.

Contractor shall submit, in writing, to Boulder County, a request for payment. Invoices shall be submitted on company letterhead and include, but not limited to, depending on the activity completed, designated project name, date(s), type of work performed. Additionally, all invoices should contain the current date, invoice number, amount due and current return address.

PRE-BID MEETING:

A Pre-bid meeting will NOT be held for this Project.

ATTACHMENTS:

The following documents are part of this BID:

1. Attachment A: Gate Design and Specifications
2. Attachment B: Site Plan
3. Attachment C: Purchase Order Terms and Conditions
4. Attachment D: Sample Contract

WRITTEN INQUIRIES:

All inquiries regarding this BID will be submitted via email to the Boulder County Purchasing Office at purchasing@bouldercounty.org on or before 2:00 p.m. **June 20, 2023**. A response from the county to all inquiries will be posted and sent via email no later than **June 22, 2023**.

Please do not contact any other county department or personnel with questions or for information regarding this solicitation.

SUBMITTAL INSTRUCTIONS:

BIDs are due at the email box only, listed below, for time and date recording on or before **2:00 p.m. Mountain Time on June 28, 2023**. A bid opening will be conducted at 3:00 p.m. via Microsoft Teams. Please click on the link below or use the call-in number. A copy of the bid tab will also be sent to all who have submitted a Bid. **Vendors must answer whether line-item pricing information submitted with a bid is confidential or closely held.**

Microsoft Teams meeting

Join on your computer, mobile app or room device

[Click here to join the meeting](#)

Meeting ID: 217 222 576 270

Passcode: FWwmd4

[Download Teams](#) | [Join on the web](#)

Or call in (audio only)

[+1 720-400-7859,894201454#](tel:+17204007859894201454) United States, Denver

Phone Conference ID: 894 201 454#

Please note that email responses to this solicitation are limited to a maximum of 50MB capacity.

NO ZIP FILES OR LINKS TO EXTERNAL SITES WILL BE ACCEPTED. THIS INCLUDES GOOGLE DOCS AND SIMILAR SITES. ALL SUBMITTALS MUST BE RECEIVED AS AN ATTACHMENT (E.G. PDF, WORD, EXCEL).

Electronic Submittals must be received in the email box listed below. Submittals sent to any other box will NOT be forwarded or accepted. This email box is only accessed on the due date of your questions or bids. Please use the Delivery Receipt option to verify receipt of your email. It is the sole responsibility of the bidder to ensure their documents are received before the deadline specified above. Boulder County does not accept responsibility under any circumstance for delayed or failed email or mailed submittals.

Email purchasing@bouldercounty.org; identified as **BID #7476-23** in the subject line.

All BIDs must be received and time and date recorded by authorized county staff by the above due date and time. Sole responsibility rests with the bidder to see that their BID response is

received on time at the stated location(s). Any BIDs received after due date and time will be returned to the bidder.

The Board of County Commissioners reserves the right to reject any and all BIDs, to waive any informalities or irregularities therein, and to accept the bid that, in the opinion of the Board, is in the best interest of the Board and of the County of Boulder, State of Colorado.

Contractors and their employees, subcontractors, and agents must comply with all federal, state, and local laws, regulations, ordinances, orders, and codes, as well as Boulder County policies, guidelines, and protocols.

AMERICANS WITH DISABILITIES ACT (ADA):

If you need special services provided for under the Americans with Disabilities Act, contact the ADA Coordinator or the Human Resources office at (303) 441-3525 at least 48 hours before the scheduled event.



Boulder County Purchasing
1325 Pearl Street
Boulder, CO 80302
purchasing@bouldercounty.org

TERMS AND CONDITIONS

-
1. Bidders are expected to examine the drawing, specifications, schedule of delivery, and all instructions. Failure to do so will be at the bidder's risk.
 2. Each bidder will furnish the information required in the Invitation to Bid.
 3. The Contract/Purchase Order will be awarded to that responsible bidder whose submittal, conforming to the Invitation to Bid, will be most advantageous to the County of Boulder, based on best value not only price.
 4. The County of Boulder reserves the right to reject any or all bids and to waive informalities and minor irregularities in bids received, and to accept any portion of or all items proposed if deemed in the best interest of the County of Boulder to do so.
 5. No submittal will be withdrawn for a period of thirty (30) days subsequent to the opening of bids without the consent of the County Purchasing Agent or delegated representative.
 6. A signed purchase order or contract furnished to the successful bidder results in a binding contract without further action by either party.
 7. Late or unsigned bids will not be accepted or considered. It is the responsibility of bidders to ensure that the bid arrives at the Purchasing email address prior to the time indicated in the "Invitation to Bid."
 8. The proposed price will be exclusive of any Federal or State taxes from which the County of Boulder is exempt by law.
 9. Any interpretation, correction or change of the bid documents will be made by Addendum. Interpretations, corrections and changes of the bid documents made in any other manner will not be binding, and bidder will not rely upon such interpretations, corrections and changes. The County's Representative will not be responsible for oral clarification.
 10. Confidential/Proprietary Information: Bids submitted in response to this "Invitation to Bid" and any resulting contract are subject to the provisions of the Colorado Open Records Act, 24-72-201 et seq., C.R.S., as amended. Any restrictions on the use or inspection of material

contained within the bid or resulting contract should be clearly stated in the bid and contract itself. Confidential/proprietary information should be readily identified, marked and/or separated from the rest of the bid. Co-mingling of confidential/proprietary and other information is NOT acceptable. Vendors must answer whether line-item pricing information submitted with a bid is confidential or closely held. Bids that do not identify confidential/proprietary information may be released in their entirety. Pricing totals contained in a bid are not considered confidential.

The Boulder County Attorney's Office retains sole authority for determining whether the Colorado Open Records Act requires or permits Boulder County to disclose proposal or bid documents, or any information contained therein, pursuant to an open records request.

11. Boulder County promotes the purchase/leasing of energy efficient materials and products with low toxicity levels when availability, quality and budget constraints allow. Proposers are expected whenever possible to provide products that earn the ENERGY STAR and meet the ENERGY STAR specifications for energy efficiency with power management features enabled. Proposers are encouraged to offer products and equipment with post-consumer recycled-content materials. Products should be packaged and delivered with a minimum amount of recycled packaging that adequately protects the product but is not excessive.
12. Pursuant to Colorado law (House Bill 1292), in any bidding process for public works in which a bid is received from a non-resident bidder who is from a state that provides a percentage bidding preference, a comparable percentage disadvantage will be applied to the bid of that bidder. Bidders may obtain additional information from the Department of Personnel's website: <http://www.colorado.gov/dpa/>.
13. Bid Security: Boulder County may require, at its discretion, bid security for construction contracts when the price is expected to exceed \$50,000 and for any other contracts as determined by Boulder County to be in its best interest. Bid security provides assurance to Boulder County that the bidder will, upon award, fulfill its bonding and contracting obligations as required by the instructions to bidders. When bid security is required, as indicated in the instructions to bidders, the following terms apply:
 - Bid security must be for an amount equal to 5 percent of the amount bid, unless otherwise stipulated in the instructions to bidders.
 - Bid security must be in the form of a bond, issued by a surety company authorized to do business in Colorado, or a bank cashier's check made payable to Boulder County.
 - Bidders should scan and submit a copy of the bid security instrument with their bid submittal AND mail to Boulder County the actual bid security instrument, postmarked no later than the date of the bid deadline.
 - Bidder noncompliance with bid security requirements requires that the bid be rejected as nonresponsive.

- The bid security is submitted as a guarantee that the bid will be maintained in full force and effect for a period of thirty (30) days after the opening of the bids. Accordingly, after bids are opened, they shall be irrevocable for a period of thirty (30) days.
- If a bidder is permitted to withdraw his bid before award, at Boulder County's sole discretion, no action shall be had against the bidder or the bid security.
- Following award, if a contractor fails to deliver the required performance and payment bonds or refuses to enter into a contract with Boulder County under the terms of its winning bid, the contractor's bid shall be rejected and its bid security will be enforced by Boulder County to the extent of actual damages.



Boulder County Purchasing
1325 Pearl Street
Boulder, CO 80302
purchasing@bouldercounty.org

SPECIFICATIONS

SPECIFICATIONS:

The contractor will construct and install the gate to the specifications and design shown in Attachment A. Construction will include mobilization of equipment, crews, materials, and will include purchasing of materials as needed, constructing all components of the gate, and gate installation. The work does not include the purchase and installation of the sound curtain panels (Echo Barrier H9).

All work, including clean up and demobilization, will be completed within thirty (30) calendar days after the date of issue of the Notice to Proceed.

MATERIAL DISPOSAL:

The Contractor is responsible for removal and proper off-site disposal of any excess materials or trash.

EQUIPMENT OPERATIONS AND MAINTENANCE:

To minimize the spread of invasive plant species, the Contractor shall wash and/or inspect vehicles and equipment before entering or leaving the project sites so that they are free of all mud, vegetative matter, organic material, seeds, and other debris. All equipment shall be thoroughly cleaned, including the undercarriages, tracks, turrets, buckets, drags, teeth, tires, etc. If vehicles and equipment are not clean upon arrival on site, the BCPOS Project Manager (PM) will request the equipment and vehicles to be removed from the site and cleaned.

HAZARDOUS MATERIALS:

Contractor will properly handle, package, transport, and dispose of hazardous materials and/or waste in accordance with all Local, State, and Federal regulations, laws, and ordinances. If hazardous substances are released to the project area during construction, these Federal, State, and Local requirements must be followed in response and cleanup.

CULTURAL RESOURCES:

If during the course of work, unmarked graves, burials, human remains, or archaeological artifacts (prehistoric or historic) are discovered, the Contractor shall stop work in the vicinity of the discovery, secure the site, and take all reasonable measures to avoid or minimize harm to the finds. All archaeological findings will be secured and access to the sensitive area restricted. The

Contractor shall notify BCPOS immediately if any cultural resources are discovered during construction.

SITE ACCESS:

Access to the project site will be from St. Vrain Rd using an established entrance and access road. Once on site the Contractor shall work to have a small limit-of-disturbance and coordinate construction activities and implementation of conservation measures to mitigate impacts with BCPOS.

Prior to commencement of work, BCPOS and Contractor shall discuss and define access points, staging and fueling areas, limits-of-disturbance and areas of no entry for equipment, and as needed, delineate such on the ground with plastic construction fencing or flagging prior to any ground disturbance or vegetation removal.

BOULDER COUNTY RESPONSIBILITIES:

BCPOS will provide reasonable access for all work. BCPOS will supply and install the sound curtain material (Echo Barrier H9) after the gate installation of the gate is completed.

BCPOS reserves the right to remove components of this project from construction, dependent on final costs and budgets.

CONTRACTOR RESPONSIBILITIES:

The Contractor will provide all necessary tools, equipment, and labor for constructing and installation of the gate noted above in the specifications here within. The Contractor will coordinate with BCPOS to identify the gate location and alignment. All associated costs shall be included in the bid. The Contractor will be responsible for providing restroom facilities at the site. Prior to the commencement of work, the Contractor will submit for approval to BCPOS material submittals for each type of material necessary to complete the work as described in the specifications here within.

PERMITS, LICENSES, LOCATES AND CODES:

The selected Contractor shall have full responsibility for identifying and obtaining, prior to the start of work, and for maintaining throughout the term of the Project, any permits and licenses which may be required in order to carry out the work. The Contractor shall also be responsible for following all State and County codes, which may be required in order to carry out the Project. The Contractor shall also be responsible for all "locates" of all public utilities related to performing work under the terms of this Contract. The Contractor shall also be responsible for insuring that any of its subcontractors performing work on the Project satisfy the provisions of this paragraph.

Contractor is responsible to contact and coordinate with utility companies regarding protection of existing utilities and special requirements at utility crossing locations, as well as, other conditions where work is nearby existing utilities. Contractor shall be responsible for all costs of

coordination with utilities including, but not limited to: outages, protection or support and any fees for costs from the utility.

CONTRACTOR LICENSING:

It is the responsibility of the selected Contractor to apply for and ensure the appropriate Contractor's license is obtained.

General contractors, HVAC contractors, and roofing contractors require licensing through the Boulder County Community Planning and Permitting Department. Electricians and plumbers are required to be licensed through the State of Colorado and registered with the Boulder County Community Planning and Permitting Department. Furthermore, it is required for all Architects, Professional Engineers and Professional Land Surveyors to be fully-licensed through the State of Colorado.

SUBCONTRACTORS:

Contractor is required to disclose to County the complete business name(s) of all potential subcontractors that will be assigned to this Project, should the Contractor be selected. Contractor acknowledges that it is completely responsible for the actions or inactions of its subcontractors. Contractor shall be responsible for the compliance of all subcontracting parties with the terms of the Contract and with any applicable local, state or federal laws or regulations. Contractor shall be solely responsible for timely payment of its subcontractors.

PROJECT COMPLETION SCHEDULE:

The successful bidder will have **thirty (30) calendar** days, after execution of the contract and after the Notice to Proceed has been issued, to complete the work.

CONFLICT OF INTEREST:

Any party that has developed, designed or drafted specifications, requirements, statements of work and/or has participated in planning activities for this Project may be excluded from consideration for the award of this Project.

CHANGE ORDERS:

Any unplanned, change orders, modifications or additional services to this Project, shall be submitted by the Contractor, in a separate, written document, including a fee schedule and completion schedule and presented to the County for review. Approval from the County, in writing, must accompany all change order requests.

OVERNIGHT CAMPING:

Boulder County prohibits any overnight camping; all operational staff, including designated security staff, are not authorized to be present at Project site from sunset to sunrise, the open space property will remain closed during these hours to the contractor and its subcontractors and/or designated representatives and/or agents, unless specifically authorized by a BCPOS representative.

HOURS OF OPERATION:

Contractor work hours shall be designated as **Monday through Friday, 7:00 a.m. to 5:00 p.m.** Work on Saturdays and Sundays, nights, and designated Federal Holidays shall not be allowed unless approved, in writing, by the County.

OWNERSHIP OF WORK PRODUCT:

All work product, property, data, documentation, information or materials conceived, discovered, developed or created by the selected Contractor pursuant to this bid and subsequent Contract will be owned exclusively by the County. To the extent possible, any Work Product will be deemed to be a work made for hire. The selected Contractor unconditionally and irrevocably transfers and assigns to the County all right, title and interest in and to any Work Product.

The selected Contractor will agree to keep confidential all County Data, and will agree not to sell, copy, modify, reproduce, republish, assign, distribute, data mine, search or disclose any such confidential information to any other person or entity without the County's written permission, including metadata (e.g. aggregations of county data or analysis of county data content).

The Contractor shall not access County accounts or County Data, except in the event as required by the express terms of a written contract between the mutual Parties and/or at the express written request of the County. All data obtained by the Contractor in the performance of this solicitation resulting in a contract shall become and remain the property of the County. The Contractor shall not use any information collected in connection with the service issued from this solicitation for any purpose other than fulfilling a County contract for this BID.



Boulder County Purchasing
1325 Pearl Street
Boulder, CO 80302
purchasing@bouldercounty.org

INSURANCE AND W-9 REQUIREMENTS

INSURANCE REQUIREMENTS:

General Liability	\$1,000,000 Each Occurrence \$2,000,000 General Aggregate \$2,000,000 Products Completed Operations Aggregate 3 years Products/Completed Operations
Automobile Liability	\$1,000,000 Each Accident *Including Hired & Non-Owned Auto
Worker's Compensation and Employer's Liability	Statutory limits
Excess or Umbrella	\$1,000,000 following form

Boulder County as Additional Insured: Boulder County shall be named as an additional insured for General Liability and Umbrella/Excess Liability as designated in this Contract. Additional insured shall be endorsed to the policy.

THE ADDITIONAL INSURED WORDING SHOULD BE AS FOLLOWS: *County of Boulder, State of Colorado, a body corporate and politic, is named as Additional Insureds.*

In regards to General Liability and Umbrella/Excess Liability:

If any or all of these coverages are required above, additional insured status will be required at the time a contract is executed.

Note that the above insurance amounts are the minimum required for this project. Proof of current insurance must be provided with your bid in the form of a sample certificate. You are NOT required to include additional insured status until the time a contract is executed.

If you require a waiver of insurance requirements you may request one in your response with an explanation.

W-9 REQUIREMENT:

Provide a copy of your business's W-9 with your bid.



Boulder County Purchasing
1325 Pearl Street
Boulder, CO 80302
purchasing@bouldercounty.org

BID TAB SECTION

<u>Item Number</u>	<u>Item Description</u>	<u>Cost</u>
1	Mobilization	\$ _____
2	Foundation	\$ _____
3	Gate Fabrication	\$ _____
4	Gate Installation	\$ _____
5	Demobilization	\$ _____
	<u>BID TOTAL</u>	\$ _____

Company Name

Name of person and title submitting BID (PLEASE PRINT)

Signature of Bidder

Date



Boulder County Purchasing
1325 Pearl Street
Boulder, CO 80302
purchasing@bouldercounty.org

SUBMITTAL CHECKLIST

The bidder’s attention is especially called to the items listed below, which must be submitted in full as part of the BID. Failure to submit any of the documents listed below as a part of your BID, or failure to acknowledge any addendum in writing with your BID, or submitting a bid on any condition, limitation or provision not officially invited in this Invitation to Bid (BID) may be cause for rejection of the BID.

THIS CHECKLIST MUST BE SUBMITTED AS PART OF YOUR BID PACKAGE: Bidder will check each box indicating compliance:

INCLUDED	ITEM
	Name and Address of company/Organization
	Telephone and Email address
	Name and Address of the Partners and Subcontractors – IF APPLICABLE
	A detailed project schedule with an all-inclusive total cost include Contractor’s ability to meet Project Completion Schedule
	Information on the relevant experience of key personnel
	State your compliance with the Terms and Conditions in the Sample Contract contained in this BID. Specifically list any deviations and provide justification for each deviation.
	Submit three (3) references for similar projects your company has completed within the last three (3) years and contact information
	Insurance Certificate – Proof of Insurance - SAMPLE
	Copies of Professional certifications and/or license - IF APPLICABLE
	Payment Bond and Performance Bond – Ability to meet requirement
	W-9 from current year
	Signature Page
	Addendum Acknowledgement(s) – IF APPLICABLE

THIS QUESTION MUST BE ANSWERED AS PART OF YOUR BID PACKAGE: Bidder will answer Yes or No indicating compliance:

YES OR NO	ITEM
	Do you customarily keep line-item pricing information, such as the information being submitted with this proposal, confidential or closely-held?



Boulder County Purchasing
1325 Pearl Street
Boulder, CO 80302
purchasing@bouldercounty.org

SIGNATURE PAGE

Contact Information	Response
Company Name including DBA	
List Type of Organization (Corporation, Partnership, etc.)	
Name, Title, and Email Address of Person Authorized to Contract with Boulder County	
Company Address	
Company Phone Number	
Company Website	

By signing below I certify that:

- I am authorized to bid on my company's behalf.
- I am not currently an employee of Boulder County.
- None of my employees or agents is currently an employee of Boulder County.
- I am not related to any Boulder County employee or Elected Official.
- (Sole Proprietorships Only) I am not a Public Employees' Retirement Association (PERA) retiree.

**Signature of Person Authorized to Bid on
 Company's Behalf**

Date

Note: If you cannot certify the above statements, please explain in a statement of explanation.

Attachment A

ST. VRAIN SOUND CURTAIN LOG DECK AND SWING GATE

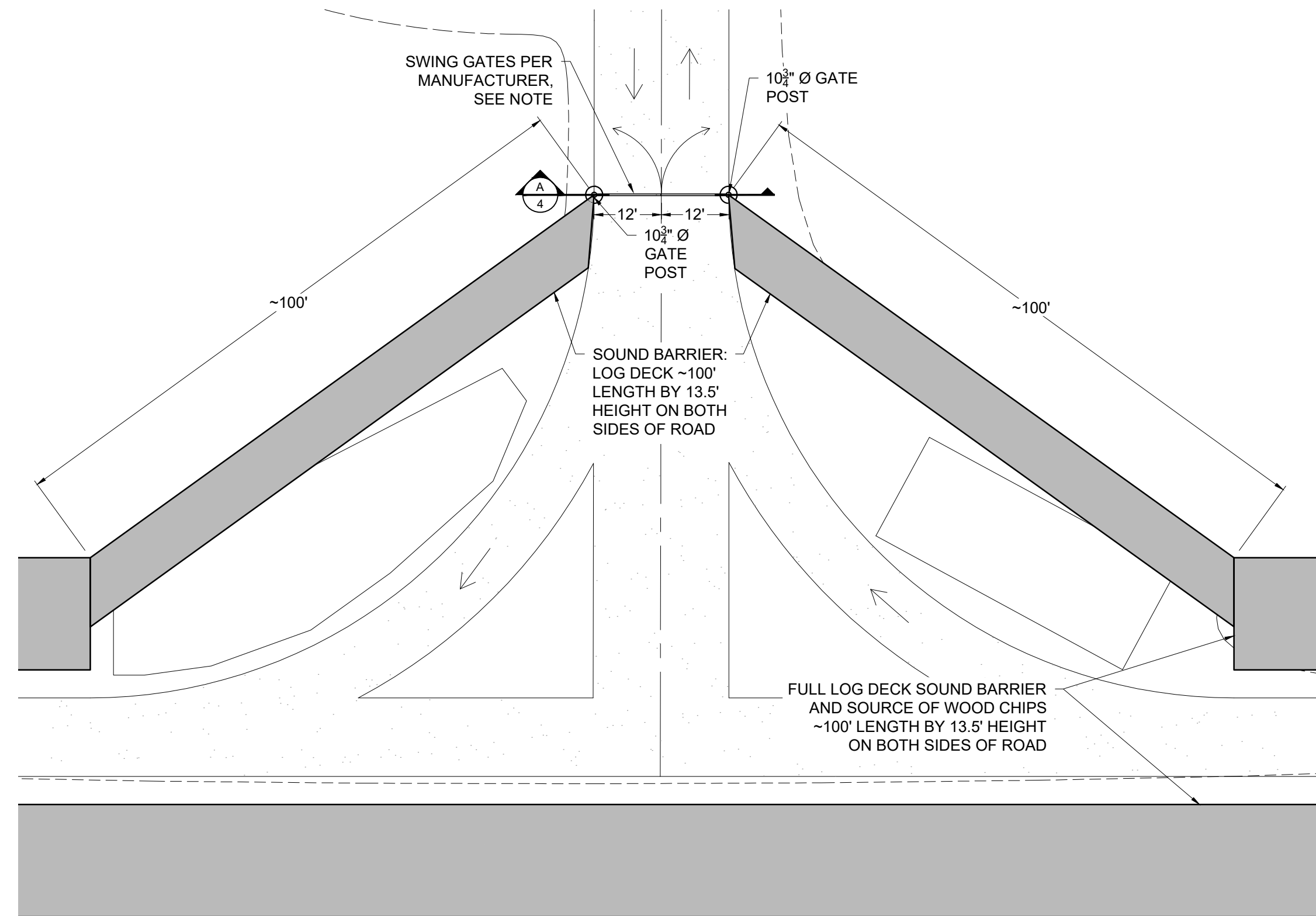

NOTE:
1. FINAL FENCE DIMENSIONS TO BE DETERMINED IN THE FIELD.

SITE PLAN
SCALE: 1" = 20'

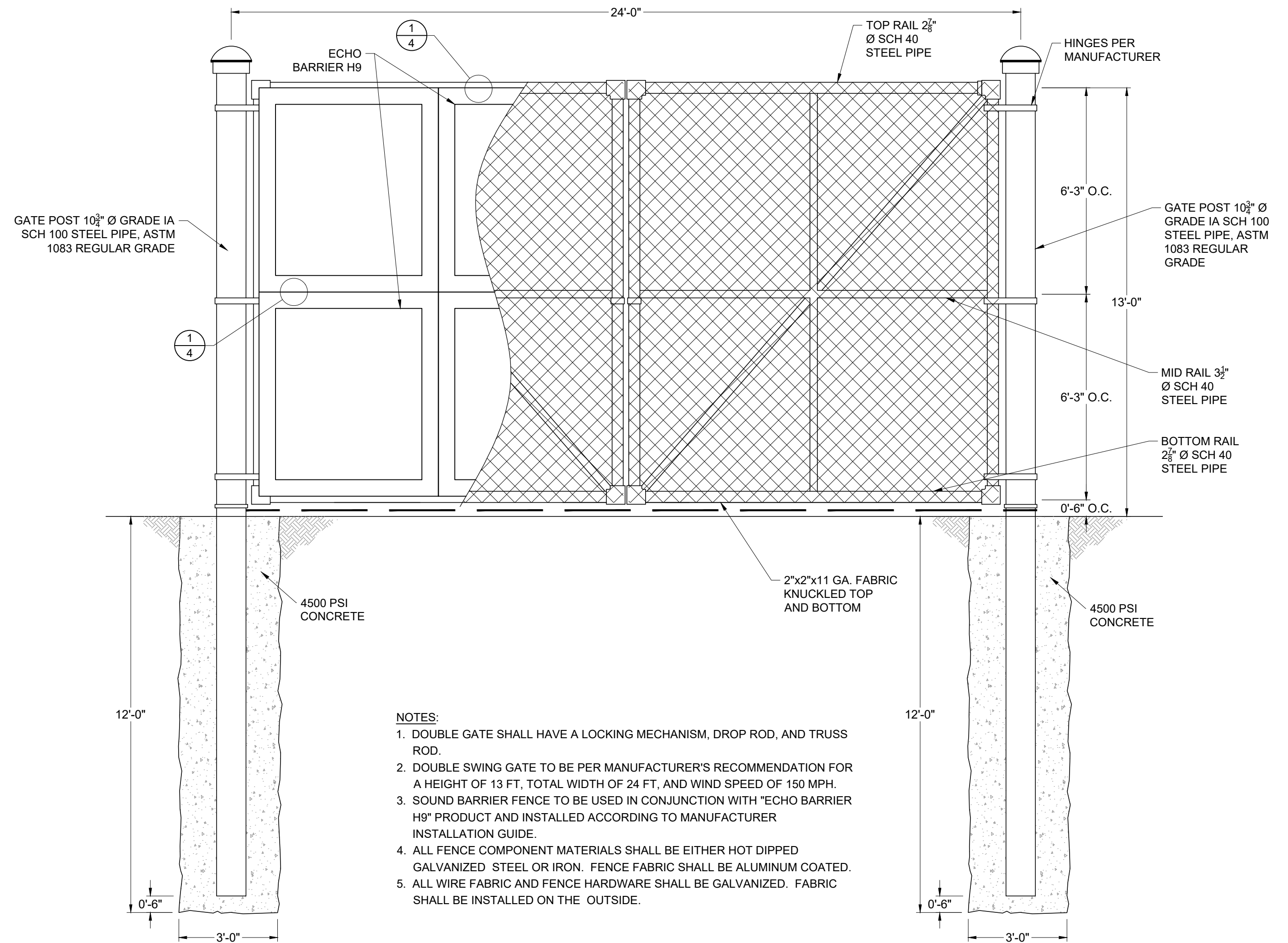
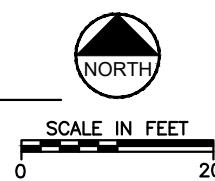

- NOTES:
1. DOUBLE GATE SHALL HAVE A LOCKING MECHANISM, DROP ROD, AND TRUSS ROD.
 2. DOUBLE SWING GATE TO BE PER MANUFACTURER'S RECOMMENDATION FOR A HEIGHT OF 13 FT, TOTAL WIDTH OF 24 FT, AND WIND SPEED OF 150 MPH.
 3. SOUND BARRIER FENCE TO BE USED IN CONJUNCTION WITH "ECHO BARRIER H9" PRODUCT AND INSTALLED ACCORDING TO MANUFACTURER INSTALLATION GUIDE.
 4. ALL FENCE COMPONENT MATERIALS SHALL BE EITHER HOT DIPPED GALVANIZED STEEL OR IRON. FENCE FABRIC SHALL BE ALUMINUM COATED.
 5. ALL WIRE FABRIC AND FENCE HARDWARE SHALL BE GALVANIZED. FABRIC SHALL BE INSTALLED ON THE OUTSIDE.

A GATE SECTION
4 SCALE: 3/8" = 1'-0"

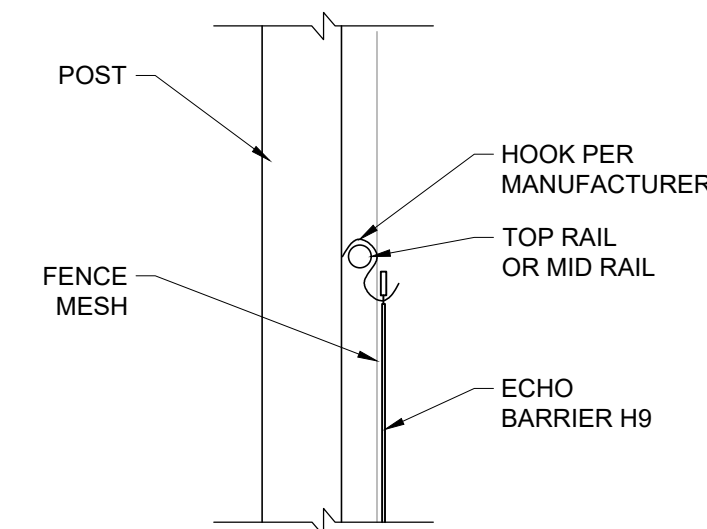
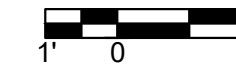

- NOTES:
1. CONNECT ECHO BARRIER TO RAIL OR FENCE AT ALL CORNERS OF BARRIER.
 2. ZIP TIES CAN BE USED AS AN ALTERNATIVE CONNECTION METHOD.

1 ECHO BARRIER CONNECTION DETAIL
4 SCALE: NTS



REVISIONS

Revision	Date	Description

Engineering Analytics, Inc.
1600 Specht Point Road, Suite 209
Fort Collins, CO 80525
(970) 488-3111

ST. VRAIN SOUND
CURTAIN

LOG DECK AND
SWING GATE

SCALE VERIFICATION:
0. IF NOT ONE INCH ON
THIS SHEET, ADJUST
SCALE ACCORDINGLY.

Drawn by: SKC
Designed by: DCH
Checked by: LCB

Scale: AS NOTED

Project No. 111343

Date: January 10, 2023

Sheets: 4 Sheet: 4

Attachment B

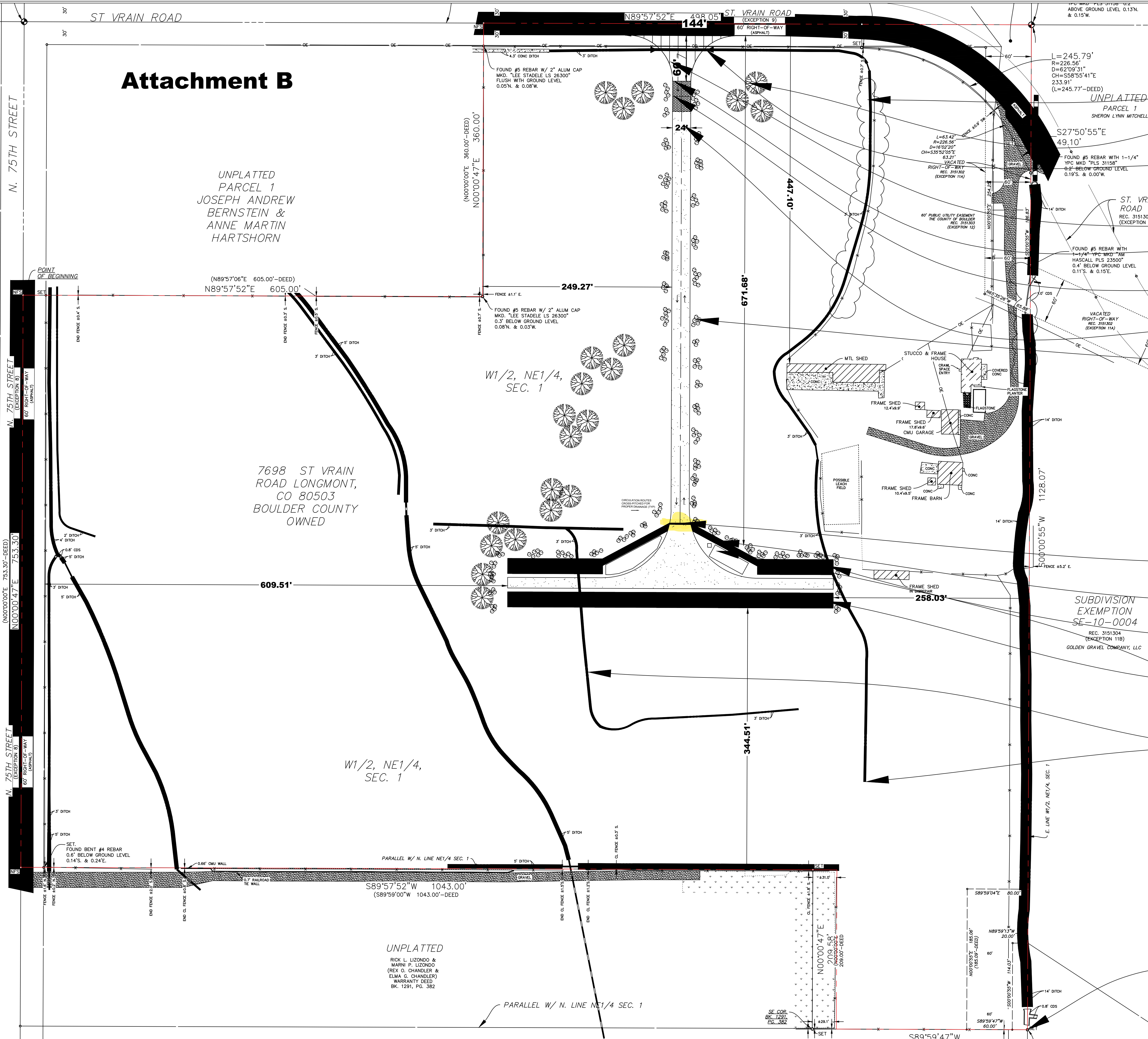

- Existing trees
- Boxelder Maple or similar fast growing tree
- 18" RCP for roadside swale & irrigation ditch
- Asphalt apron (TYP.)
- Proposed new entrance & exit from facility
- Locking Gate (TYP.)
- Road base (TYP)
- Small shrubs: Combination of: Rabbitbrush, New Mexico, Crusader Hawthorn or similar
- Sound barrier: Sound curtain along gate-
- Sound barrier: Wood log decks
- Possible employee parking & Port-O-Let
- Sound barrier: Wood log decks
- Fill in 3' abandoned irrigation ditch as needed
- Property Line (TYP)

UNPLATTED
PARCEL 1
JOSEPH ANDREW
BERNSTEIN &
ANNE MARTIN
HARTSHORN

7698 ST VRAIN
ROAD LONGMONT,
CO 80503
BOULDER COUNTY
OWNED

W1/2, NE1/4,
SEC. 1

UNPLATTED
RICK L. LIZONDO &
MARIN P. LIZONDO
(REX O. CHANDLER &
ELMA G. CHANDLER)
WARRANTY DEED
BK. 1291, PG. 382

UNPLATTED
PARCEL 1
SHERON LYNN MITCHELL

ST. VRAIN
ROAD
REC. 3151302
(EXCEPTION 11)

SUBDIVISION
EXEMPTION
SE-10-0004
REC. 3151304
(EXCEPTION 11B)
GOLDEN GRAVEL COMPANY, LLC

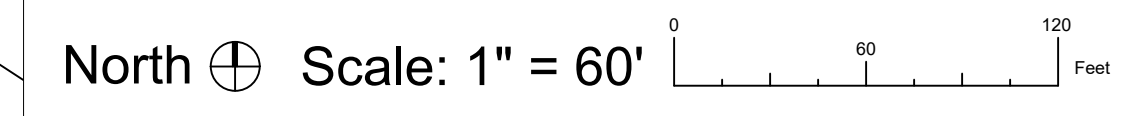

Boulder County
Parks & Open Space
5201 St. Vrain Road
Longmont, CO 80503
Phone: (303) 678-6200
Fax: (303) 678-6180
www.BoulderCounty.org

ST. VRAIN FORESTRY YARD

BOULDER COUNTY YARD

7698 ST VRAIN RD LONGMONT, CO 80503

SCALE: 1" = 60'
DRAWN BY: BP
DESIGNED BY: BP
CHECKED BY: MO

SUBMITTAL	DATE
	2023-02-07

SHEET: # of #

L1

TERMS AND CONDITIONS

THE ARTICLES SPECIFIED ARE SUBJECT TO THE FOLLOWING CONDITIONS

1. The offer of seller, either orally or in writing, shall for all purposes be deemed accepted upon execution of this purchase order.
2. No terms additional to or different from those contained herein shall be valid or effective unless otherwise specified on this purchase order.
3. The Seller acknowledges that it has carefully reviewed and examined this purchase order with all of its incorporated documents attached, and the Seller will not make any claim to the Purchaser based upon or arising out of any misunderstanding or misconception on its part of the provisions and requirements of this purchase order: The seller acknowledges that it has fully examined and analyzed all conditions that could affect its performance and that no conditions exist which would affect the progress, performance, or price of this purchase order.
4. The making of payment shall not constitute an acceptance of any defective or incomplete work.
5. The failure of the Seller to perform any material obligation of this purchase order shall be deemed a default and Purchaser shall thereon be entitled, in addition to any other legal rights and remedies it may have, to cancel this purchase order. The Seller shall be responsible and liable to purchaser for all damages, costs, disbursements and expenses, including attorney's fees, incurred by the Purchaser as a result of the seller's breach or default of this purchase order.
6. This purchase order shall not be changed, modified, or altered except in writing and signed by Seller and Purchaser.
7. The right of cancellation in case of long delay in shipment is reserved.
8. No sales tax or use tax shall be included in or added to prices of materials on this order.
9. If the quantity shipped is short of the purchase order quantity, specify on the packing slip if that quantity is on backorder or canceled.
10. On prepaid freight shipments, copy of freight bill must accompany invoice.
11. This purchase order shall not be assigned in whole or in part nor shall any interest therein including the right to any proceeds and any such purported assignment shall be void.
12. Financial obligations of the county are contingent upon funds for that purpose being appropriated, budgeted, and otherwise made available as a result, the county reserves the right to terminate this agreement should necessary funds not be appropriated, budgeted, or otherwise made available.
13. If this purchase order covers equipment, materials, or containers thereof that are required by law to be constructed, packaged, labeled, or registered in a prescribed manner - such as, but not limited to, fabrics, poisons, combustibles gases, and any vehicles, storage tanks, and the like intended for transporting or storing the same. Seller hereby warrants that such equipment, materials, and containers will be in compliance with all such laws irrespective of whether Seller's shipments to Purchaser are interstate or intrastate. This provision applies whether or not a specification is furnished by Purchaser. No extra charges of any kind including charges for boxing, packaging, or cartage shall be allowed.
14. Seller hereby warrants for a period of one year after acceptance of all materials furnished hereunder by Purchaser, that all materials furnished hereunder will be free from all faults and defects, fit and sufficient for the purpose intended, merchantable, of good workmanship and in conformity with any specifications, drawings or samples specified or furnished herewith.
15. The validity, interpretation and performance of this Purchase Order shall be governed by the laws of the State of Colorado. Titles, captions or headings to any provisions, Articles, etc., shall not limit the full contents of same. If any term or provision of this purchase order is found invalid, it shall not affect the validity and enforcement of all remaining terms and provisions of this purchase order.

Contract

DETAILS SUMMARY	
Document Type	New Contract
OFS Number-Version	
County Contact Information	
Boulder County Legal Entity	Boulder County
Department	Parks and Open Space
Division/Program	Resource Management - Forestry
Mailing Address	5201 St. Vrain Road Longmont, CO 80503
Contract Contact – Name Email	Rosa Brohm rbrohm@bouldercounty.org
Project Contact – Name Email Phone Number	TBD TBD TBD
Invoice Contact – Name, email	Boulder County Parks and Open Space Department Accounts Payable pospayables@bouldercounty.org
Contractor Contact Information	
Contractor Name	TBD
Contractor Mailing Address	TBD
Contact 1- Name, title, email	TBD
Contact 2- Name, title, email	TBD
Contract Term	
Start Date	The Start Date shall be the date of last party signature as set forth on the Signature Page of this Contract. NOTE: Work shall not commence until a Notice to Proceed is provided by County to Contractor in accordance with paragraph 3.
Expiration Date	XX/XX/2023 NOTE: Work must be performed during the time period set forth in paragraph 3.
Final End Date	12/31/2028
Contract Amount	
Contract Amount	TBD
Fixed Price or Not-to-Exceed?	Not-to-Exceed
Brief Description of Work	
<p>BID # XXXX-23; St Vrain Forestry Yard Gate Installation</p> <p>The project is for the construction and installation of a galvanized metal gate for the BCPOS Forestry Storage Yard at the Ramey (Shadi) Property. The property is located at 7698 St Vrain Rd Longmont, CO 80503. The gate is part of a sound mitigation system that will reduce the amount noise to neighboring properties from activities at the yard.</p>	

Contract Documents	
a. Formal Procurement (RFP/Bid/SOQ) No. Bid Variable (the "Bid Documents")	
b. Contractor's proposal in response to the Bid Documents (the "Proposal")	
c. Project Details, including project-specific terms and a Scope of Work, attached as Exhibit A (the "Scope of Work")	
d. Fee Schedule, attached as Exhibit B (the "Fee Schedule")	
Purchasing Details – County Internal Use Only	
Grant Funded?	No
Bid Number	
Award Date	
If no Bid No., bid process used	Bid number provided above
COVID-19	NO
Project #	N/A
Purchasing Notes <i>(optional)</i>	N/A
Contract Notes	
<i>Additional information not included above</i>	
Project subject to Payment Bonds and Performance Bonds	
Project subject to Retainage	
Project subject to Contractor Evaluation	
Project subject to Notice of Final Settlement	
RESERVED CLAUSES – 53 Geographic Information System (GIS) Data	
ACCOUNT CODE: 126-27502-75430-1005-102634-O111-3199 Task 1	

THIS CONTRACT ("Contract") is entered into by and between the Board of County Commissioners on behalf of the County of Boulder, State of Colorado, a body corporate and politic, for the benefit of the Parks and Open Space Department ("County") and [Supplier] ("Contractor"). County and Contractor are each a "Party," and collectively the "Parties."

In consideration of the mutual covenants contained in this Contract, the receipt and sufficiency of which is hereby acknowledged, the Parties agree as follows:

1. Incorporation into Contract: The **Details Summary** is incorporated into this Contract. The **Contract Documents** are incorporated into this Contract by reference, except to the extent that the Proposal, if any is incorporated, contains any obligations placed upon County and not otherwise contained in this Contract.

2. Work to be Performed: Contractor will provide all labor and equipment and do all tasks necessary and incidental to performing the work as described in the **Details Summary** and **Contract Documents** (the "Work"). Contractor will perform the Work (i) in a good and workmanlike manner, (ii) at its own cost and expense, (iii) in accordance with recognized industry standards of care, skill and diligence for the type of work being performed, and (iv) in strict accordance with the Contract. County and its representatives shall have access to the Work at all times.

a. Contractor shall supervise and direct the Work and shall be solely responsible for all construction means, methods, techniques, sequences and procedures and for coordinating all portions of the Work under the Contract.

b. Contractor shall provide and pay for all labor, materials, equipment, tools, construction equipment and machinery, transportation, and other facilities and services necessary for the proper execution and completion of the Work. Contractor warrants that all materials incorporated into the Work will be new unless otherwise specified.

c. Contractor shall at all times enforce good order among its employees and shall not employ on the Work any unfit person or anyone not skilled in the task assigned to such person. Contractor shall initiate, maintain, and supervise all safety precautions and programs in connection with the Work to ensure safe conditions on the premises at all times. Contractor shall comply with all laws, regulations, ordinances, rules, and orders of any public authority bearing on the safety of persons and property. In the event that County notifies Contractor of any unsafe conditions or practices, Contractor shall immediately take all actions required to remediate them at no expense to County. County reserves the right to immediately suspend the Work in the event of imminent hazard, as determined by County.

d. At all times, Contractor shall keep the premises free from accumulation of waste materials or rubbish caused by Contractor's operations. Upon completion of the Work, Contractor shall remove all of its waste materials and rubbish from the premises, as well as its tools, construction equipment, machinery and surplus materials.

e. Contractor shall confine operations on the premises to areas permitted by law, ordinances, permits, this Contract, and as directed by County, including storage of any materials or equipment.

f. Any claim for an increase in the **Contract Amount** shall be made and generally described by Contractor in writing and delivered to County promptly, in no event later than thirty

(30) days after the occurrence of the event giving rise to the claim. Notice of the amount of the claim with supporting data shall be delivered to County within sixty (60) days after such occurrence and shall be accompanied by Contractor's written statement that the amount claimed covers all known amounts to which Contractor is entitled as a result of the occurrence of said event. All claims for increase in the **Contract Amount** shall be determined by County if the Parties are unable to otherwise reach agreement on the claim.

g. Before ordering any materials or doing any Work, Contractor shall verify all measurements for the Work and shall be responsible for the correctness of same.

3. Term of Contract: The **Contract Term** begins on the **Start Date** and expires on the Expiration Date. Notwithstanding, Work shall not commence until the County has provided a NOTICE TO PROCEED to Contractor, which shall set forth the date that Contractor may begin the Work. As specified in **BID# XXXX-XX**, Contractor shall have thirty (30) calendar days to complete the Work, unless this Contract is terminated earlier or the County grants Contractor a written extension in accordance with paragraph 6 or 7. In no event shall Work be performed outside the **Contract Term**.

4. Payment for Work Performed: In consideration of the Work performed by Contractor, and subject to conditions contained in this Contract, County will pay an amount not to exceed the **Contract Amount** to Contractor in accordance with the **Contract Documents**.

5. Invoicing: Contractor will promptly provide a copy of its Form W-9 and invoice template to County upon request. Contractor must submit an invoice to the County by the fifteenth (15th) day of the month for completion of any Work performed in the prior calendar month. All invoices submitted require the following components: Contractor's name and address (submitted W-9 address must match remit address), detailed description of services, dates of services, itemization of labor and materials costs, "Bill to: Boulder County" language, payment remittance address, payer, name and address, date of invoice, unique invoice number, and total amount due. Contractor must send all completed invoices to the **Invoice Contact** in the **Details Summary**. County may require delivery of invoices by email. Failure to submit invoices in a timely manner and in accordance with the terms of this Contract may cause a delay in payment. County may recoup any damages incurred because of Contractor's failure to submit invoices pursuant to the terms of this paragraph. County's acceptance or payment of an invoice will not constitute acceptance of any Work performed under this Contract.

6. Extra Time to Complete the Work (Additional Time only): If Contractor cannot complete the Work by the **Expiration Date**, Contractor may request extra time to complete the Work. County, in its sole discretion, may grant Contractor additional time to complete the Work by sending a written notice of extension to Contractor. An extension of time to complete the Work will not entitle Contractor to additional compensation from County.

7. Extension of Contract Term (Additional Time and Work): Upon mutual agreement of the Parties, this Contract may be extended until the **Final End Date**. During any extended **Contract Term**, the terms of this Contract will remain in full force and effect, unless otherwise amended in writing by the Parties. Where the Contractor will provide additional services for additional compensation beyond the initial **Contract Amount**, the Parties must execute a written amendment before the then-current **Expiration Date**. If necessary, the written amendment will incorporate an updated Scope of Work and updated Fee Schedule as exhibits. Contractor must provide a current Certificate of Insurance to the County that complies with the **Insurance Requirements** of this Contract, if any, prior to any extended **Contract Term**.

8. **Schedule of Work:** County may designate the hours (on a daily or weekly basis) during which Contractor may perform the Work, strictly for the purposes of minimizing inconvenience to the County and interference with County operations. Contractor will otherwise set its own work schedule. Contractor shall promptly notify County of any aspect of the Work that will not be delivered or accomplished according to the initial schedule.

9. **Indemnity:** Contractor will be liable for any damages to persons or property caused by or arising out of the actions, obligations, or omissions of Contractor, its employees, agents, representatives or other persons acting under Contractor's direction or control in performing or failing to perform the Work under this Contract. Contractor will indemnify and hold harmless County, its elected officials and appointed department heads, and its employees, agents and representatives (the "indemnified parties"), from any and all liability, claims, demands, actions, damages, losses, judgments, costs or expenses, including attorneys' fees, which may be made or brought or which may result against any of the indemnified parties as a result or on account of the actions or omissions of Contractor, its employees, agents or representatives, or other persons acting under Contractor's direction or control. This indemnification obligation will extend to claims based on Contractor's unauthorized use or disclosure of confidential information and intellectual property infringement. County will not be obligated to indemnify or defend Contractor under any circumstances. Contractor's obligations under this provision shall survive expiration or termination of this Contract. Nothing contained in this Contract or the **Contract Documents** is intended to limit or restrict the indemnification rights or obligations of any Party under this provision, or damages available for breaches of the obligations herein.

10. **Nondiscrimination:** Contractor will comply with the Colorado Anti-Discrimination Act, C.R.S. § 24-34-401, *et seq.*, as amended, and all applicable local, State and Federal laws concerning discrimination and unfair employment practices. County prohibits unlawful discrimination on the basis of race, color, religion, gender, gender identity, national origin, age 40 and over, disability, socio-economic status, sexual orientation, genetic information, or any other status protected by applicable Federal, State or local law. Contractor must require that its subcontractors, if any, similarly comply with all applicable laws concerning discrimination and unfair employment practices.

11. **Information and Reports:** Contractor will provide to authorized County, State, and Federal government representatives all information and reports that may be required for any purpose authorized by law. Contractor will permit access to such representatives to Contractor's facilities, books, records, accounts, and any other relevant sources of information. Where information required by a representative is in the exclusive possession of a person or entity other than Contractor, Contractor must so certify to the County and explain what efforts it has made to obtain the information.

12. **Independent Contractor:** Contractor is an independent contractor for all purposes in performing the Work. None of Contractor, its agents, personnel or subcontractors are employees of the County for any purpose, including the Federal Insurance Contribution Act, the Social Security Act, the Federal Unemployment Tax Act, the provisions of the Internal Revenue Code, the Colorado Workers' Compensation Act, the Colorado Unemployment Insurance Act, and the Public Employees Retirement Association. Accordingly, County will not withhold or pay any income tax, payroll tax, or retirement contribution of any kind on behalf of Contractor or Contractor's employees. As an independent contractor, Contractor is responsible for employing and directing such

personnel and agents as it requires to perform the Work. Contractor will exercise complete authority over its personnel and agents and will be fully responsible for their actions.

13. Termination

a. Breach: Either Party's failure to perform any of its material obligations under this Contract, in whole or in part or in a timely or satisfactory manner, will be a breach. The institution of proceedings under any bankruptcy, insolvency, reorganization or similar law, by or against Contractor, or the appointment of a receiver or similar officer for Contractor or any of its property, which is not vacated or fully stayed within thirty (30) days after the institution of such proceeding, will also constitute a breach. In the event of a breach, the non-breaching Party may provide written notice of the breach to the other Party. If the breaching Party does not cure the breach, at its sole expense, as reasonably determined by the non-breaching Party in its sole discretion, within thirty (30) days after delivery of notice, the non-breaching Party may exercise any of its remedies provided under this Contract or at law, including immediate termination of this Contract.

b. Non-Appropriation: The other provisions of this Contract notwithstanding, County is prohibited by law from making commitments beyond the current fiscal year. Payment to Contractor beyond the current fiscal year is contingent on the appropriation and continuing availability of funding in any subsequent year. County has reason to believe that sufficient funds will be available for the full **Contract Term**. Where, however, funds are not allocated for any fiscal period beyond the current fiscal year, County may terminate this Contract without penalty by providing seven (7) days' written notice to Contractor.

c. Convenience: In addition to any other right to terminate under this Section 13, County may terminate this Contract, in whole or in part, for any or no reason, upon seven (7) days' advance written notice to Contractor.

14. Contractor Obligations upon Termination or Expiration: By the **Expiration Date** or effective date of termination, if earlier, Contractor must (1) remove from County property all of its personnel, equipment, supplies, trash and any hazards created by Contractor, (2) protect any serviceable materials belonging to the County, and (3) take any other action necessary to leave a safe and healthful worksite. Any items remaining on County property after the Expiration Date or the effective date of termination, if earlier, will be deemed abandoned by Contractor.

15. Payable Costs in Event of Early Termination: If County terminates this Contract before the **Expiration Date**, Contractor's payments (and any damages associated with any lawsuit brought by Contractor) are limited to only (1) payment for Work satisfactorily executed and fully and finally completed, as determined by County in its sole discretion, prior to delivery of the notice to terminate, and (2) the reasonable and actual costs Contractor incurred in connection with performing the Work prior to delivery of the notice to terminate. Contractor explicitly waives all claims it may have against the County for any other compensation, such as anticipatory profits or any other consequential, special, incidental, punitive or indirect damages.

16. Remedies for Non-Performance: If Contractor fails to perform any of its obligations under this Contract, County may, at its sole discretion, exercise one or more of the following remedies (in addition to any other remedies provided by law or in this Contract), which shall survive expiration or termination of this Contract:

a. Suspend Performance: County may require that Contractor suspend performance of all or any portion of the Work pending necessary corrective action specified by the County and without entitling Contractor to an increase in compensation or extension of the performance schedule. Contractor must promptly stop performance and incurring costs upon delivery of a notice of suspension by the County.

b. Withhold Payment Pending Corrections: County may permit Contractor to correct any rejected Work at the County's discretion. Upon County's request, Contractor must correct rejected work at Contractor's sole expense within the time frame established by the County. Upon full and final completion of the corrections satisfactory to the County, County will remit payment to Contractor.

c. Deny Payment: County may deny payment for any Work that does not comply with the requirements of the Contract or that Contractor otherwise fails to provide or fully and finally complete, as determined by the County in its sole discretion. Upon County request, Contractor will promptly refund any amounts prepaid by the County with respect to such non-compliant Work.

d. Removal: Upon County's request, Contractor will remove any of its employees or agents from performance of the Work, if County, in its sole discretion, deems any such person to be incompetent, careless, unsuitable, or otherwise unacceptable.

17. Binding Arbitration Prohibited: County does not agree to binding arbitration by any extra-judicial body or person.

18. Conflicts of Interest: Contractor may not engage in any business or personal activities or practices or maintain any relationships that conflict in any way with the full performance of Contractor's obligations.

19. Notices: All notices provided under this Contract must be in writing and sent by Certified U.S. Mail (Return Receipt Requested), electronic mail, or hand-delivery to the other Party's **Contact** at the address specified in the **Details Summary**. For certified mailings, notice periods will begin to run on the day after the postmarked date of mailing. For electronic mail or hand-delivery, notice periods will begin to run on the date of delivery.

20. Statutory Requirements: This Contract is subject to all statutory requirements that are or may become applicable to counties or political subdivisions of the State of Colorado generally, including but not limited to: C.R.S. § 38-26-107, which requires withholding funds where the County receives a claim for payment from a supplier or subcontractor of Contractor upon notice of final settlement (required for public works contracts that exceed \$150,000); C.R.S. § 8-17-101 et seq.; C.R.S. § 18-8-301, et seq.; and C.R.S. § 18-8-401, et seq.

21. Legal Interpretation. Each Party recognizes that this Contract is legally binding and acknowledges that it has had the opportunity to consult with legal counsel of its choice about this Contract. The rule of construction providing that any ambiguities are resolved against the drafting Party will not apply in interpreting the terms of this Contract.

22. Entire Agreement/Binding Effect/Amendments: This Contract represents the complete agreement between the Parties and is fully binding upon them and their successors, heirs, and assigns, if any. This Contract terminates any prior agreements, whether written or oral in whole or in part, between the Parties relating to the Work. This Contract may be amended only by a written agreement signed by both Parties.

23. Assignment/Subcontractors: This Contract may not be assigned or subcontracted by Contractor without the prior written consent of the County. If Contractor subcontracts any of its obligations under this Contract, Contractor will remain liable to the County for those obligations and will also be responsible for subcontractor's performance under, and compliance with, this Contract. Contractor shall not contract with a person or entity to whom County has made a reasonable objection.
24. Governing Law/Venue: The laws of the State of Colorado govern the construction, interpretation, performance, and enforcement of this Contract. Any claim relating to this Contract or breach thereof may only be brought exclusively in the Courts of the 20th Judicial District of the State of Colorado and the applicable Colorado Appellate Courts.
25. Breach: The failure of either Party to exercise any of its rights under this Contract will not be deemed to be a waiver of such rights or a waiver of any breach of the Contract. All remedies available to a Party in this Contract are cumulative and in addition to every other remedy provided by law.
26. Severability: If any provision of this Contract becomes inoperable for any reason but the fundamental terms and conditions continue to be legal and enforceable, then the remainder of the Contract will continue to be operative and binding on the Parties.
27. Third-Party Beneficiary: Enforcement of the terms and conditions and all rights and obligations of this Contract are reserved to the Parties. Any other person receiving services or benefits under this Contract is an incidental beneficiary only and has no rights under this Contract. Notwithstanding, where the beneficiary **Department** is led by an Elected Official, such Elected Official shall be considered a third-party beneficiary.
28. Colorado Open Records Act: County may disclose any records that are subject to public release under the Colorado Open Records Act, C.R.S. § 24-72-200.1, et seq.
29. Conflict of Provisions: If there is any conflict between the terms of the main body of this Contract and the terms of any of the **Contract Documents**, the terms of the main body of the Contract will control.
30. Governmental Immunity: Nothing in this Contract shall be construed in any way to be a waiver of the County's immunity protection under the Colorado Governmental Immunity Act, C.R.S. § 24-10-101, et seq., as amended.
31. Representations and Warranties: Contractor represents and warrants the following:
- a. Execution of this Contract and performance thereof is within Contractor's duly authorized powers;
 - b. The individual executing this Contract is authorized to do so by Contractor;
 - c. Contractor is authorized to do business in the State of Colorado and is properly licensed by all necessary governmental and public and quasi-public authorities having jurisdiction over the Work and the Contractor; and
 - d. Contractor and its subcontractors, if any, are financially solvent, able to pay all debts as they mature, and have sufficient working capital to complete the Work and perform all obligations under the Contract.

32. Legal Compliance: Contractor assumes full responsibility for obtaining and maintaining any permits and licenses required to perform the Work. Contractor is solely responsible for insuring that its performance under this Contract and the Work itself will comply with all Federal, State, and local laws, regulations, ordinances and codes. Contractor shall promptly notify County if any drawings or specifications are at variance with any laws, regulations, ordinances, or codes. If Contractor performs any Work contrary to such laws, regulations, ordinances, or codes, Contractor shall bear all costs arising therefrom. County approval of the Work or any aspect of Contractor's performance, such as drawings, specifications, plans, designs, or other Contractor-drafted documents, shall not be interpreted to mean that Contractor has satisfied its obligations under this Section.

33. Litigation Reporting: Contractor is not currently involved in any action before a court or other administrative decision-making body that could affect Contractor's ability to perform the Work. Contractor will promptly notify the County if Contractor is served with a pleading or other document in connection with any such action.

34. Tax Exemption: County is exempt from payment of Federal, State, and local government taxes. Contractor shall collect no tax from the County, and the County shall not be liable to pay any taxes imposed on Contractor. County shall provide its tax exemption status information to Contractor upon request.

35. Delegation of Authority: The Parties acknowledge that the Board of County Commissioners has delegated authority to the Department Head or Elected Official that leads the beneficiary **Department** and their designees to act on behalf of the County under the terms of this Contract, including but not limited to the authority to terminate this Contract.

36. Ownership of Work Product: All work product, property, data, documentation, information or materials conceived, discovered, developed or created by Contractor pursuant to this Contract ("Work Product") will be owned exclusively by the County. To the extent possible, any Work Product will be deemed to be a work made for hire. Contractor unconditionally and irrevocably transfers and assigns to the County all right, title and interest in and to any Work Product.

37. Publicity Releases: Contractor will not refer to this Contract or the County in commercial advertising without prior written consent of the County. This provision shall survive expiration or termination of this Contract.

38. Execution by Counterparts; Electronic Signatures: This Contract may be executed in multiple counterparts, each of which will be deemed an original, but all of which will constitute one agreement. The Parties approve the use of electronic signatures, governed by the Uniform Electronic Transactions Act, C.R.S. §§ 24 71.3 101 to 121. The Parties will not deny the legal effect or enforceability of this Contract solely because it is in electronic form or because an electronic record was used in its creation. The Parties will not object to the admissibility of this Contract in the form of electronic record, or paper copy of an electronic document, or paper copy of a document bearing an electronic signature, because it is not in its original form or is not an original.

39. Limitation on Public Statements and Lobbying Activity. During the term of this Contract, Contractor may receive from the County its confidential data, work product, or other privileged or confidential information that is protected by law. To maintain the fact and appearance of absolute objectivity, Contractor shall not, without the prior written consent of the County, which shall not be unreasonably withheld, do any of the following: (a) disclose information obtained because of this

contractual relationship to any third party; (b) lobby any State or Federal agency on any pending matter while this Contract is effective; or (c) make any public statements or appear at any time to give testimony at any public meeting on the subject matters regarding which Contractor is or was retained by the County. County may set reasonable conditions on any disclosure authorized by the County under this provision. Notwithstanding, Contractor may make disclosures as required by law, and to law enforcement officials in connection with any criminal justice investigation.

40. Sustainability: All construction, deconstruction, remodel, and office move projects are required to follow construction waste procedure modeled off of Boulder County BuildSmart Code, International Green Construction Code (IGCC), International Energy Conservation Code (IECC), and Leadership in Energy and Environmental Design (LEED) certification, as an effort to achieve maximum jobsite waste diversion, energy efficiency, and water conservation. All 'demolition projects' are to follow deconstruction procedures. Instead of demolition project materials being crushed and primarily sent to the landfill, these projects should be systematically dismantled, typically in the opposite order they were constructed, in order to maximize the salvage of materials. Any hazardous materials encountered should follow state and federal standards, and contractor shall leverage the Boulder County Hazardous Materials Management facility for hazardous materials. The development of a project diversion plan is encouraged to include material types and volume/weight estimations as well as planned destinations. Projects must track all jobsite waste.

41. Limitation of Liability: COUNTY SHALL NOT BE LIABLE TO CONTRACTOR FOR ANY SPECIAL, CONSEQUENTIAL, INCIDENTAL, PUNITIVE, OR INDIRECT DAMAGES ARISING FROM OR RELATING TO THIS CONTRACT, REGARDLESS OF ANY NOTICE OF THE POSSIBILITY OF SUCH DAMAGES. COUNTY'S AGGREGATE LIABILITY, IF ANY, ARISING FROM OR RELATED TO THIS CONTRACT, WHETHER IN CONTRACT, OR IN TORT, OR OTHERWISE, IS LIMITED TO, AND SHALL NOT EXCEED, THE AMOUNTS PAID OR PAYABLE HEREUNDER BY COUNTY TO CONTRACTOR. ANY CONTRACTUAL LANGUAGE LIMITING CONTRACTOR'S LIABILITY SHALL BE VOID.

42. County Opportunity to Review: Contractor shall provide County with the opportunity to review and approve or take other appropriate action upon the Contractor's submittals, such as Shop Drawings, Product Data, and Samples, but only for conformance with the design concept of the Work and with the information given in the Contract Documents.

43. Notice to Proceed: The Parties agree that time is of the essence and work will begin after a "Notice to Proceed" has been issued by the County and in accordance with the terms therein.

44. Retainage: County may retain partial payment pending completion and County acceptance of the Work as satisfactory and fully and finally complete. *For contracts that exceed \$50,000, the retention rate shall not exceed ten percent (10%)*. C.R.S. § 24-91-103. Contractor is responsible for submitting a final invoice for any retainage held by County. If It becomes necessary for County to take over completion of the Work, all of the amounts owing to Contractor, including the withheld percentage, shall be applied: First, towards completion of the Work; second, towards performance of the withholding requirement set forth in C.R.S. § 38-26-107; third, to the surety furnishing bonds for the Work, to the extent such surety has incurred liability or expense in competing the Work or made payments pursuant to C.R.S. § 38-26-106; then, to Contractor. Such retained percentage as may be due to Contractor shall be due and payable as provided by C.R.S. § 38-26-107.

45. Bonds: Upon County's request, Contractor shall obtain and deliver to County payment and performance bonds each equal to 100% of the total Contract. Bonds shall be executed by a qualified corporate surety and must be acceptable to County. County reserves the right to accept other acceptable forms of surety in lieu of a bond, and to reduce the bond requirements set forth herein consistent with C.R.S. § 38-26-106.

46. Change Orders: If unforeseen modifications or changes are required, Contractor may submit a Change Order request to County, which must include a complete description, timeline, and fee schedule for the proposed work. Change Orders are not effective until approved by County in writing.

47. No Suspension or Debarment: Contractor certifies, and warrants for the duration of this Contract, that neither it nor its principals nor any of its subcontractors are debarred, suspended, proposed for debarment, declared ineligible, or voluntarily excluded from participation in this Contract by any Federal or State department or agency. Contractor shall comply, and shall require its subcontractors to comply, with subpart C of 2 C.F.R. § 180.

48. Permits/Licenses/Code Compliance: Prior to starting the Work, Contractor will identify and obtain, and maintain during this Contract, all permits and licenses necessary to perform the Work. Contractor shall comply with all State and local codes. Contractor is responsible for locating all public utilities, as necessary. Contractor shall require its subcontractors to comply with this provision. HVAC, roofing, and general contractors must be licensed through Boulder County Land Use. Electricians and plumbers must be licensed through the State and registered with Boulder County Land Use Building Safety and Inspection Division. Architects, Professional Engineers and Professional Land Surveyors must be fully-licensed through the State. All required permits and licenses must be provided to County prior to Contractor beginning the Work.

49. Stormwater Quality Protection Requirements: Contractor will take all measures necessary to prevent pollutants from entering storm drains and watercourses. To eliminate stormwater pollution, Contractor shall implement effective Best Management Practices (BMPs). BMPs include general good housekeeping practices, appropriate scheduling of activities, operational practices, maintenance procedures and other measures to prevent the discharge of pollutants directly or indirectly to the storm drain system. These BMPs shall be maintained for the duration of this Contract. Contractor shall also be responsible for proper disposal of all waste materials, including wastes generated by the implementation of BMPs. Contractor shall otherwise comply with the Federal Clean Water Act, Colorado Water Quality Control Act, and Boulder County's local Clean Water Act, Illegal Discharge Ordinance (No. 2012-4). For work performed in urbanized areas, Contractor must comply with the requirements of MS4 permit (COR090000), which is available through the Colorado Department of Public Health and Environment.

50. Guaranties and Warranties: Upon completion of the Work, Contractor will provide County with a written guaranty covering all labor, materials and workmanship incorporated into the Work for one (1) year, or within any such longer period of time as may be prescribed by law, the specifications, or any other applicable special warranty required by the **Contract Documents**. Final payment upon full and final completion of the Work will not relieve Contractor of responsibility for faulty material or workmanship, which County may require Contractor to fix at Contractor's

sole expense, in addition to County's other remedies. This provision shall apply to Work completed by Contractor's employees and subcontractors.

51. Final Payment: A final inspection of the Work shall be conducted by County. If a list of deficiencies results from such final inspection, Contractor shall promptly rectify all items appearing thereon before final payment will be made. When County indicates acceptance of the Work, Contractor may request final payment from County, including any retained amounts. Final payment shall be subject to C.R.S. § 38-26-107.

52. Notice of Final Settlement: Prior to remitting final payment to Contractor, County shall publish a Notice of Final Settlement in accordance with C.R.S. § 38-26-107. Final payment will be rendered in accordance with the statute and the other terms of this Contract. Final payment will not be rendered until County, in its sole discretion, determines full and final completion of the Work.

53. Geographic Information System (GIS) Data: [RESERVED]

54. State Specifications: The Standard Specifications for Road and Bridge Construction 2017, either in whole or as set forth in the Bid Documents, are expressly incorporated into this Contract by reference.

55. Determination of Unit Prices: County will determine the actual quantities and classifications of Unit Price Work performed by Contractor. The Parties will review the County's preliminary determinations before County renders a written decision thereon (by recommendation of an Application for Payment or otherwise), which shall be final and binding upon Contractor. The value of any Unit Price Work covered by a Change Order or claim for an increase or decrease in the Contract Amount shall be determined by applying the unit prices to the quantities of items.

a. Where the Contract Documents provide that all or part of the Work is to be Unit Price Work, the Parties agree that the Contract Amount includes the total cost of Unit Price Work, determined by multiplying the quantity of each item by its unit price. Initial quantity determinations are estimates, which must be adjusted to reflect actual quantities. Contractor shall make a claim in writing to County for any additional amounts owed where actual quantities exceed estimated quantities. Contractor shall provide such written claim within twenty (20) days of providing the items and shall be accompanied by supporting documentation. The written claim shall include a statement that the claimed amount covers all known amounts (direct, indirect and consequential) to which Contractor is owed. County shall only pay Contractor for actual quantities of items provided hereunder.

b. The Parties agree that each unit price adequately covers Contractor's overhead and profit for each item.

56. Records Retention/Access/Audits: Contractor shall maintain all records and documents pertaining to this Contract in accordance with the requirements prescribed by County. Such records shall be maintained for a period of five (5) calendar years after the date of Contractor's final payment from County under this Contract. Contractor agrees that County or their designated representative shall have the right to review and to copy any records and supporting documentation pertaining to the performance of this Contract as necessary and upon request, throughout the term of this Contract, and for five (5) calendar years after the date of the final

payment hereunder. Contractor agrees to allow the auditor(s) access to such records during normal business hours and to allow interviews of any employees who might reasonably have information related to such records. County and Contractor acknowledge that protected information is exempt from this requirement without proper client release.

57. Insurance: Prior to commencing the Work, Contractor will provide a Certificate of Insurance to the County demonstrating adequate insurance coverage as required by this paragraph. All policies evidencing coverage required by the Contract will be issued by insurance companies satisfactory to the County. Contractor will forward Certificates of Insurance directly to the **County Department** and **Contact** listed in the **Details Summary**.

a. Boulder County as Additional Insured: Boulder County shall be named as an additional insured for General Liability, Umbrella/Excess Liability, and Pollution Liability, as designated in this Contract. Additional insured shall be endorsed to the policy.

THE ADDITIONAL INSURED WORDING SHOULD BE AS FOLLOWS: *County of Boulder, State of Colorado, a body corporate and politic, is named as Additional Insured.*

b. Notice of Cancellation: Each insurance policy required by this Contract shall provide the required coverage and shall not be suspended, voided or canceled except after thirty (30) days' prior written notice has been given to the County except when cancellation is for non-payment of premium, then ten (10) days' prior notice may be given. If any insurance company refuses to provide the required notice, Contractor or its insurance broker shall notify the County any cancellation, suspension, or nonrenewal of any insurance policy within seven (7) days of receipt of insurers' notification to that effect.

c. Insurance Obligations of County: County is not required to maintain or procure any insurance coverage beyond the coverage maintained by the County in its standard course of business. Any insurance obligations placed on the County in any of the **Contract Documents** shall be null and void.

d. Deductible: Any and all deductibles contained in any insurance policy shall be assumed by and at the sole risk of Contractor.

e. Primacy of Coverage: Coverage required of Contractor and its subcontractors, if any, shall be primary over any insurance or self-insurance program carried by the County.

f. Subrogation Waiver: All insurance policies in any way related to this Contract secured or maintained by Contractor as required herein shall include clauses stating that each carrier shall waive all rights of recovery, under subrogation or otherwise, against County, its organizations, officers, agents, employees, and volunteers.

g. Requirements. For the entire duration of this Contract including any extended or renewed terms, and longer as may be required by this Contract, Contractor shall procure and maintain at its own expense, and without cost to the County, the following kinds and minimum amounts of insurance to insure the liability risks that Contractor has assumed under this Contract:

i. **Commercial General Liability**

This coverage should be provided on an Occurrence Form, ISO CG001 or equivalent, with Minimum limits of \$1,000,000 Each Occurrence, \$2,000,000 General Aggregate and \$2,000,000 Products Completed Operations Aggregate.

ii. **Automobile Liability**

Bodily Injury and Property Damage for any owned, hired, and non-owned vehicles used in the performance of the Contract. Minimum limits \$1,000,000 Each Accident.

iii. **Workers' Compensation and Employer's Liability**

Workers' Compensation must be maintained with the statutory limits. Employer's Liability is required for minimum limits of \$100,000 Each Accident/\$500,000 Disease-Policy Limit/\$100,000 Disease-Each Employee.

iv. **Umbrella / Excess Insurance**

Umbrella/Excess Liability insurance in the amount \$1,000,000.00, following form.

58. **Survival After Termination:** Upon expiration or termination of this Contract, the obligations which by their nature are intended to survive expiration or termination of this Contract, will survive, including but not limited to the *re-seeding and/or re-vegetative* obligations set forth in the Scope of Work.

59. **Cultural Artifacts:** To ensure the preservation of significant cultural artifacts and historical materials at the Project site, the County will inform the Contractor of the probability of cultural artifacts or historical materials being uncovered during the Project prior to the Notice to Proceed being issued. It shall be the Contractor's responsibility to communicate that probability to any Subcontractors. The County, when deemed applicable, will make a Cultural Resource Specialist available to supervise ground disturbance/structural renovation operations at the Project site. It is the Contractor's responsibility, if any cultural artifacts or historical materials are uncovered, to cease all ground disturbance/structural renovation operations and notify the County immediately. The Contractor shall not remove any findings from Project site; all findings remain the property of the County. The Cultural Resource Specialist shall document any findings, as well as provide retrieval and/or securing the area at no cost to Contractor.

[Signature Page to Follow]

IN WITNESS WHEREOF, the Parties have executed and entered into this Contract as of the latter day and year indicated below.

SIGNED for and on behalf of Boulder County	SIGNED for and on behalf of Contractor
Signature:	Signature:
Name:	Name:
Title:	Title:
Date:	Date:
↓↓ <i>For Board-signed documents only</i> ↓↓	
Attest:	<i>Initials</i>
Attestor Name:	
Attestor Title:	